

# KOKKUPANEKUJUHEND

## Aiamööblikomplekt ABER, 78328



### Lugege ja säilitage allolevad instruksioonid enne kokkupanekut

1. Eraldage ja identifitseerige kõik osad. Tehke kindlaks, et kõik osad on olemas.
2. Vältimaks kriimustusi kokkupaneku ajal, teostage kokkupanek pehmel matil või sarnasel pinnal.
3. Pange toode kokku järk-järgult ja järgige juhiseid.
4. Kasutage seibe.
5. Kui iga kruvi ja mutter on kinnitatud, ärge neid liiga tugevalt pingutage.
6. Ärge kinnitage kruve ja mutreid lõpuni enne, kui kõik kruvid on kinnitatud.







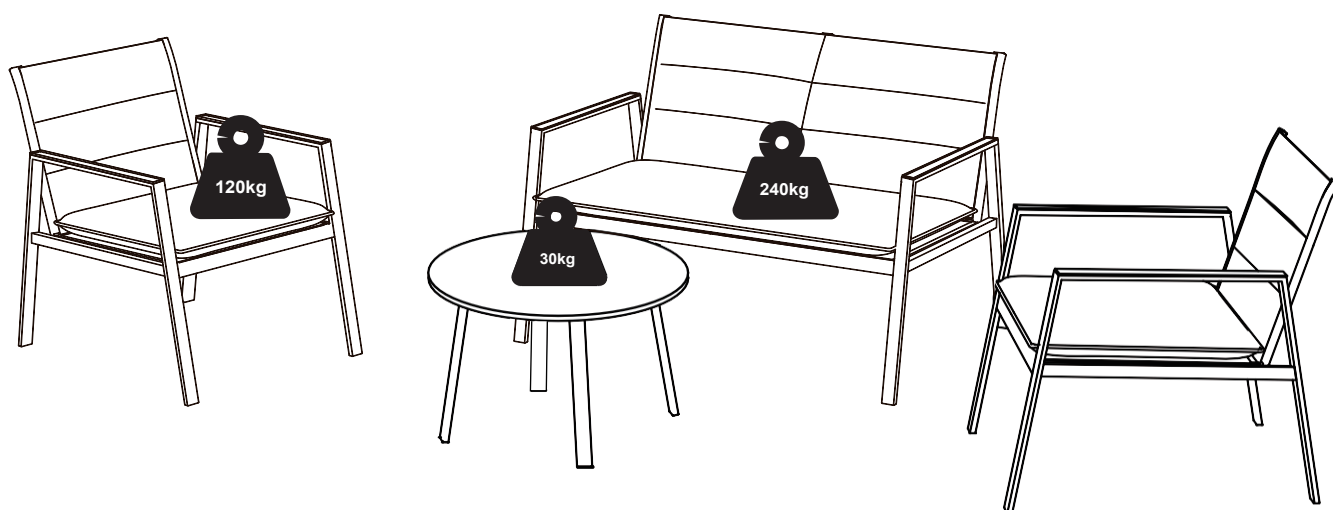





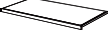









Paigaldage kõik olulised kruvid, aga ärge kinnitage neid alguses lõplikult. Pingutage kruvid lõplikult ükshaaval.

Ärge kinnitage kruvi enne kui alustate järgmise paigaldamist.



LISTA CZĘŚCI / PARTS LIST / SEZNAM DÍLŮ

Ax3	Bx3	Cx2	C1x1	Dx2	D1x1	Ex2	E1x1	Kx1	Lx1	Mx1
										
Fx12	Gx14	Hx26	Ix6	Jx2	Nx4	Ox1	Px4	Qx1	Rx1	
										
M6x25mm	M6x35mm	M6x14mm		M6	M8x12mm	M5x12mm	M8x16mm		M8	

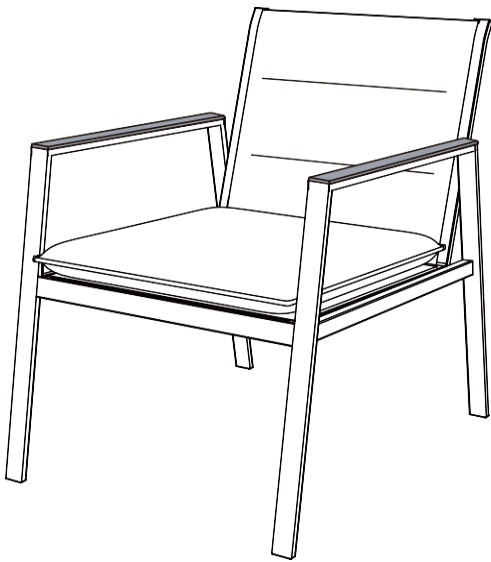

Ax2	Bx2	Cx2	Dx2	Ex2
Fx8	Gx8	Hx16	Ix4	Jx1
M6x25mm	M6x35mm	M6x14mm		M6

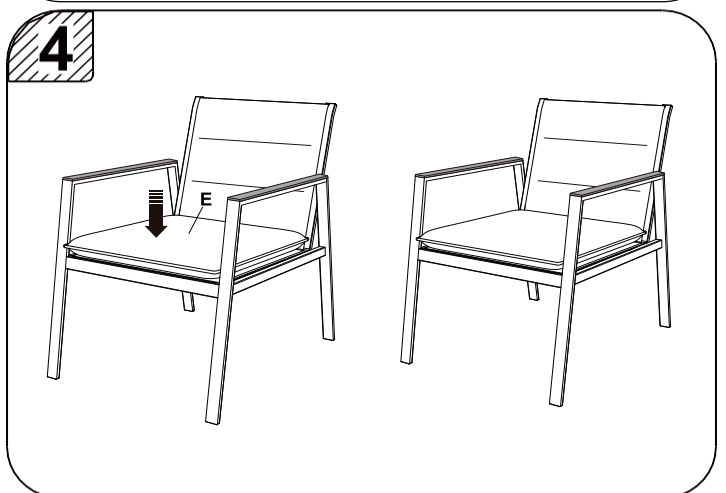
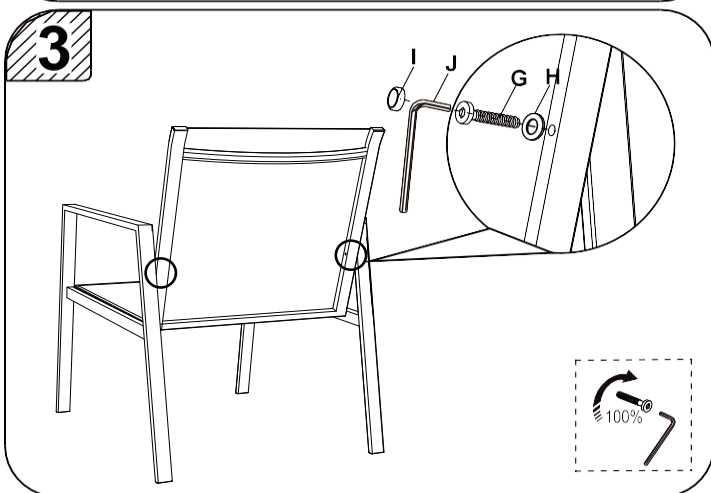
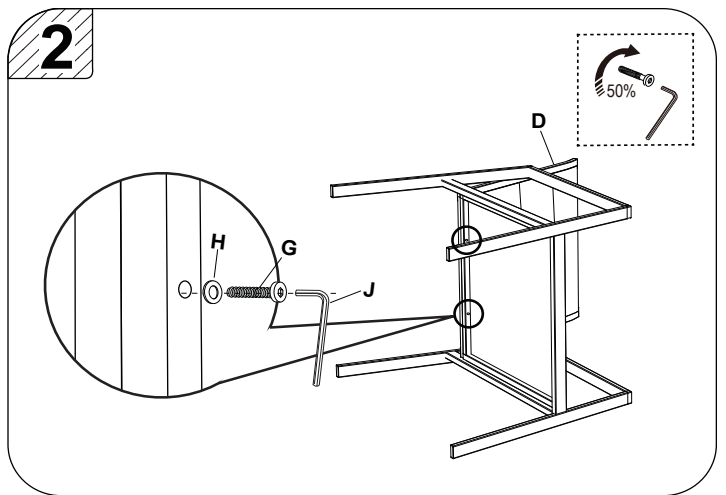
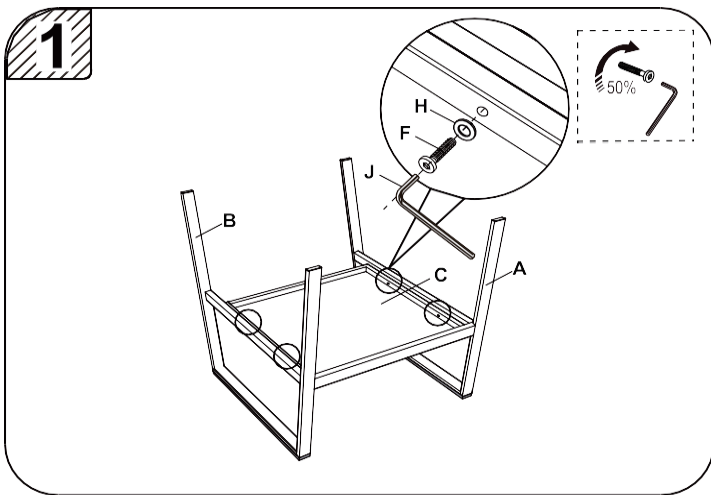

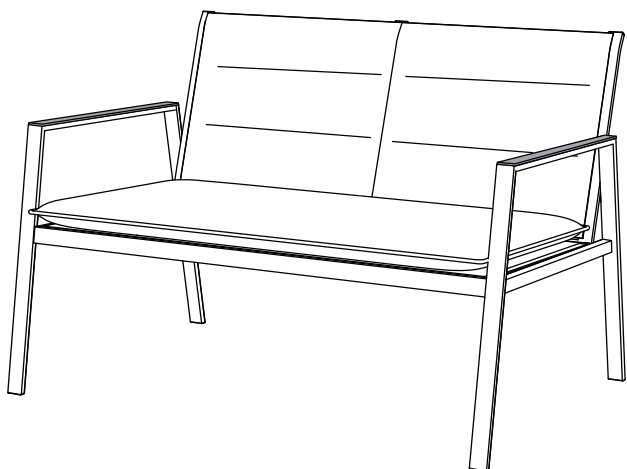

Ax1	Bx1	C1x1	D1x1	E1x1
Fx4	Gx6	Hx10	Ix2	Jx1
 M6x25mm	 M6x35mm	 M6x14mm		 M6

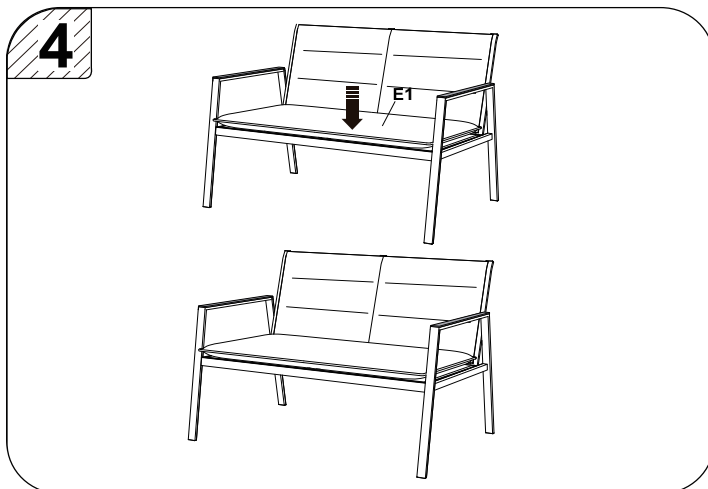
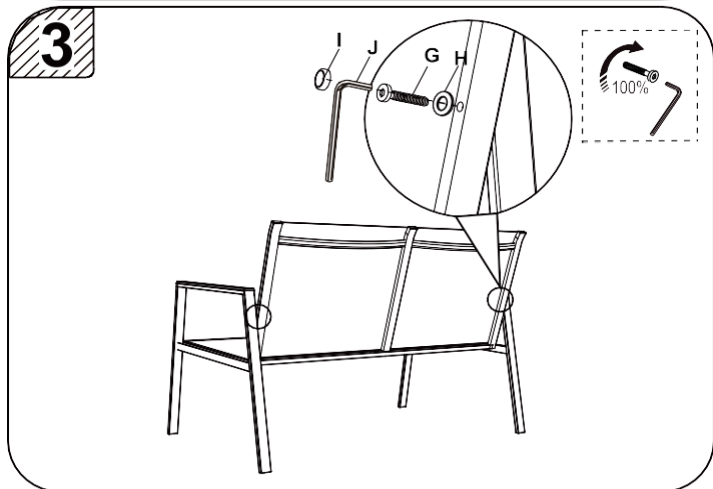
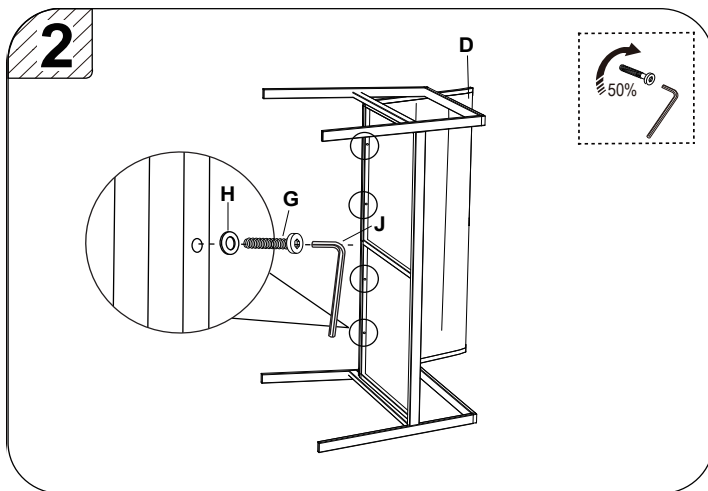
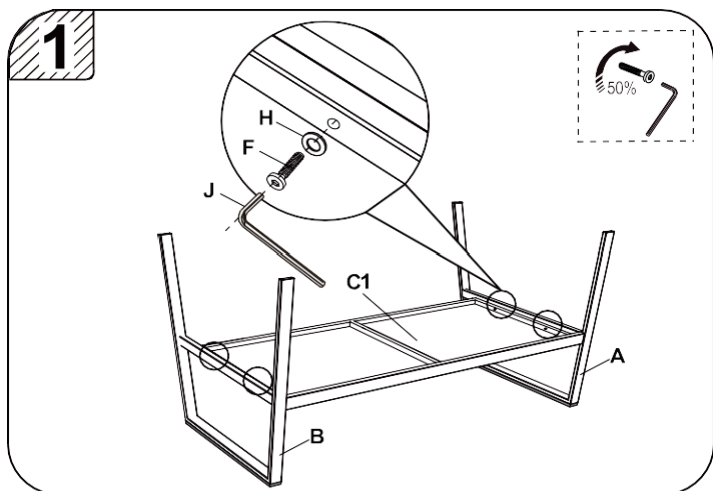

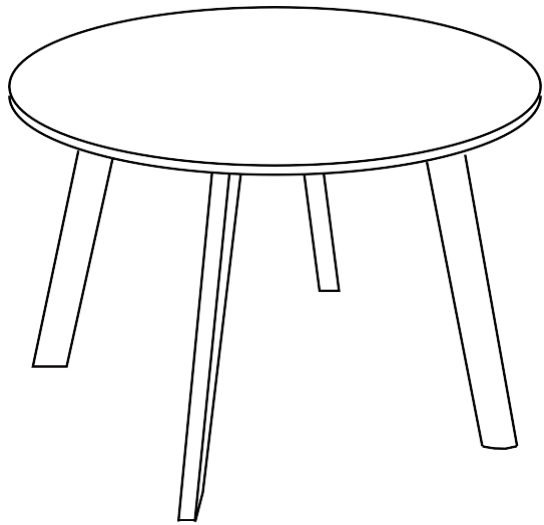

Kx1		Lx1		Mx1
Nx4	Ox1	Px4	Qx1	Rx1
M8x12mm	M5x12mm	M8x16mm		M8

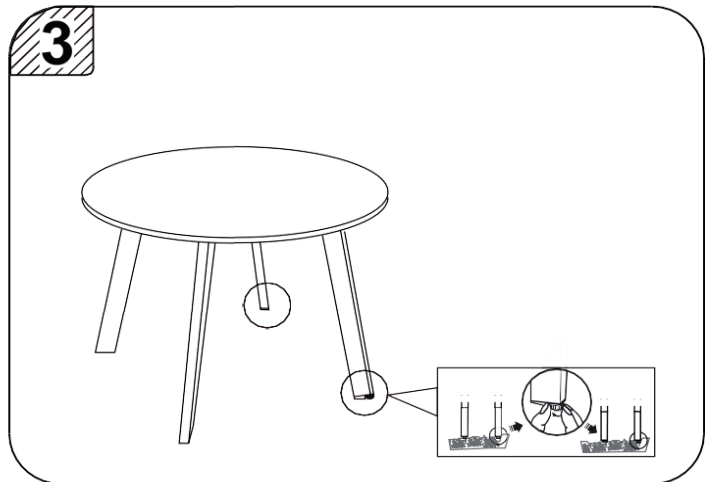
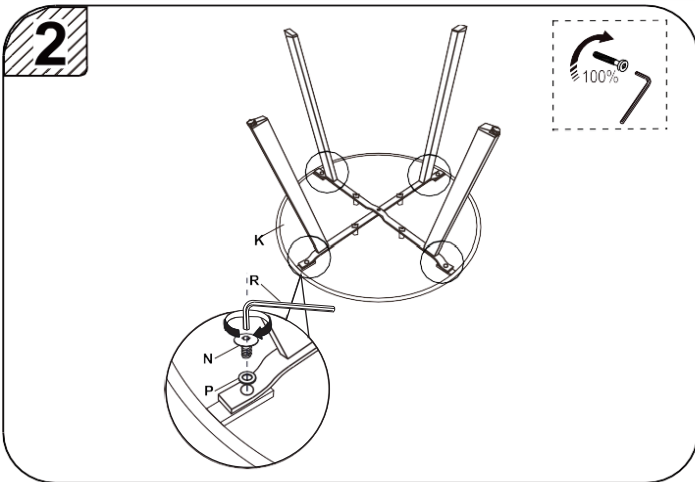
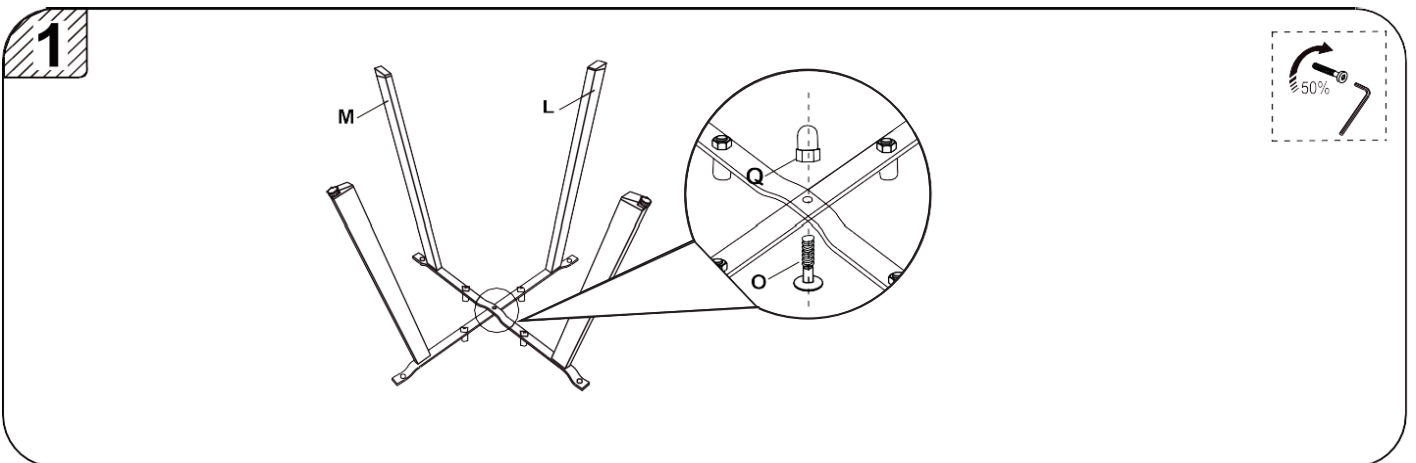

## HOOLDUS JA PUHASTAMINE

1. Puhastamiseks pühkige niiske lapiga. Ärge kasutage valgendajat, happelisi lahusteid ega abrasiivseid puhastusvahendeid.
2. Muutlike ilmastikuolude korral ja talvel tuleks toode hoiustada kuivas kohas.
3. Katke toode vastava kattega, mis on puhas ja kuiv.
4. Kui metall peaks kriimustuse tagajärjel välja tulema, töödelge roostetõrjelakiga.
5. Kontrollige aeg-ajalt, et kõik kruvid oleksid täielikult kinni.
6. Sobilik mööblimate on tugevalt soovitatav, et pikendada kasutusiga.