

Assembly Instructions

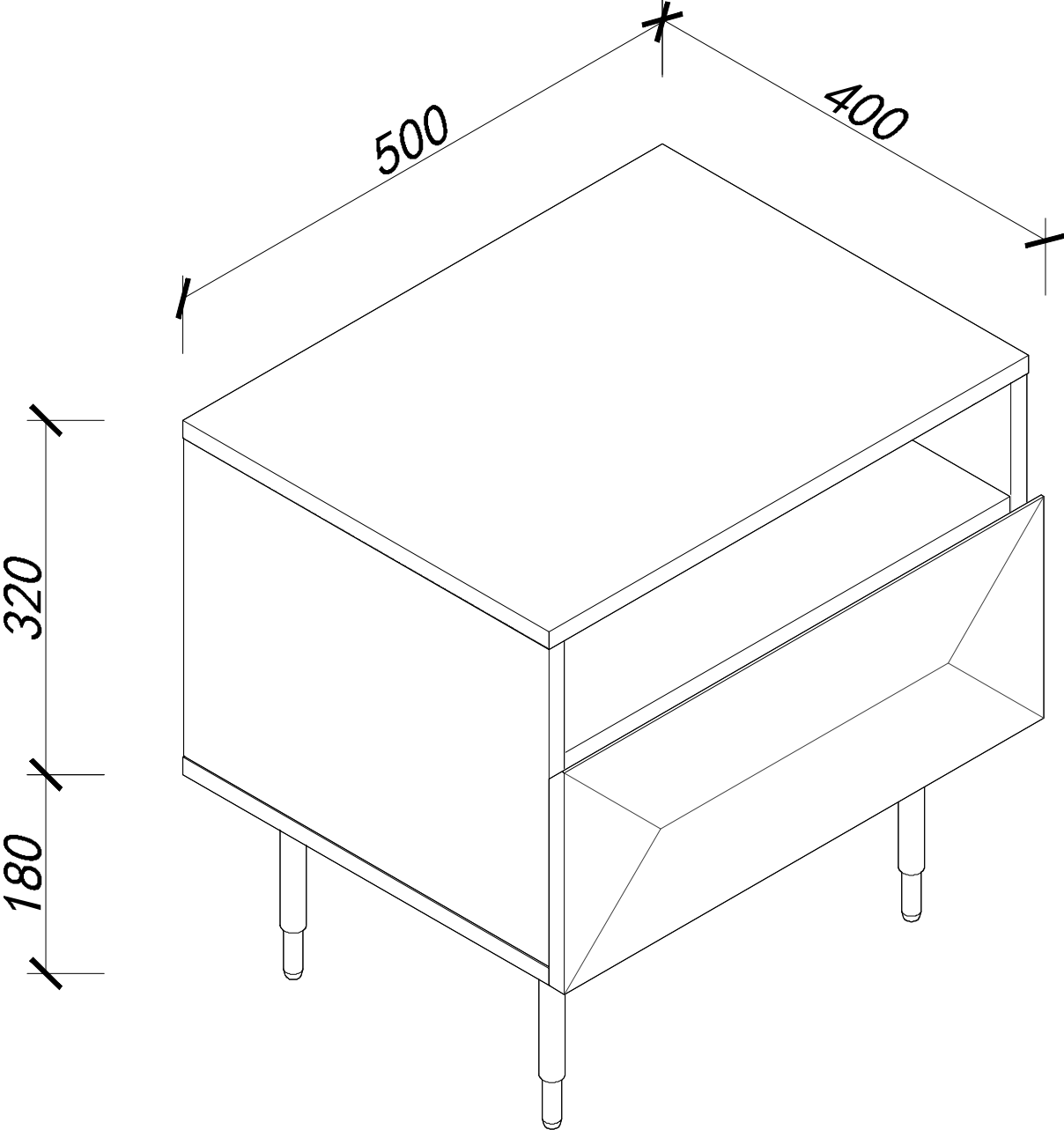

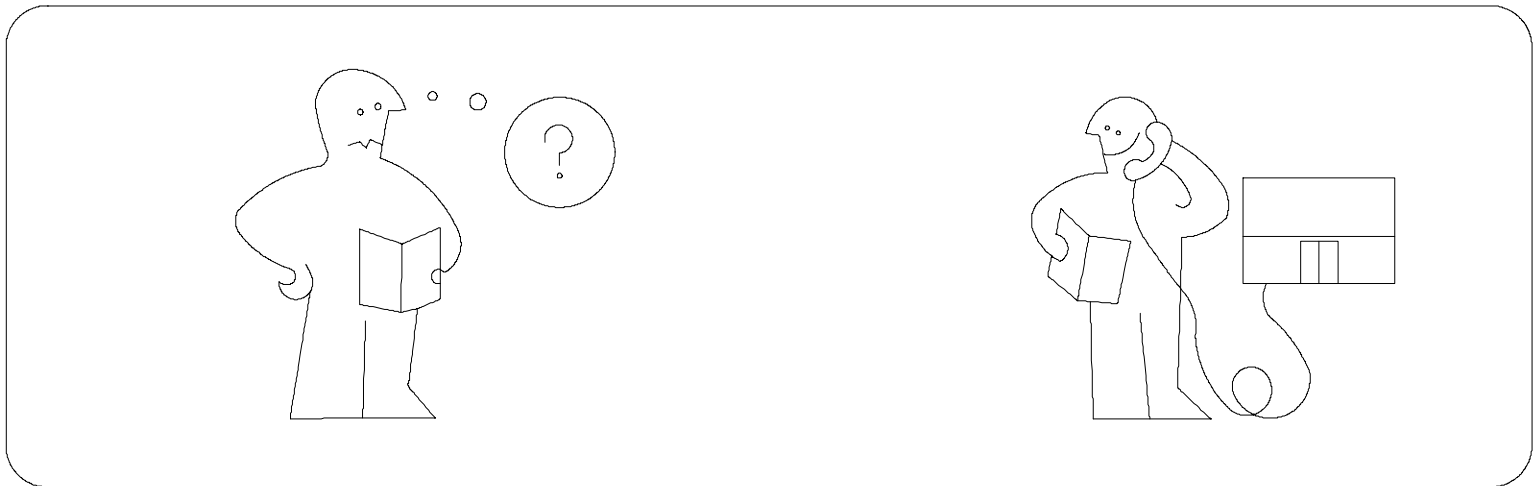
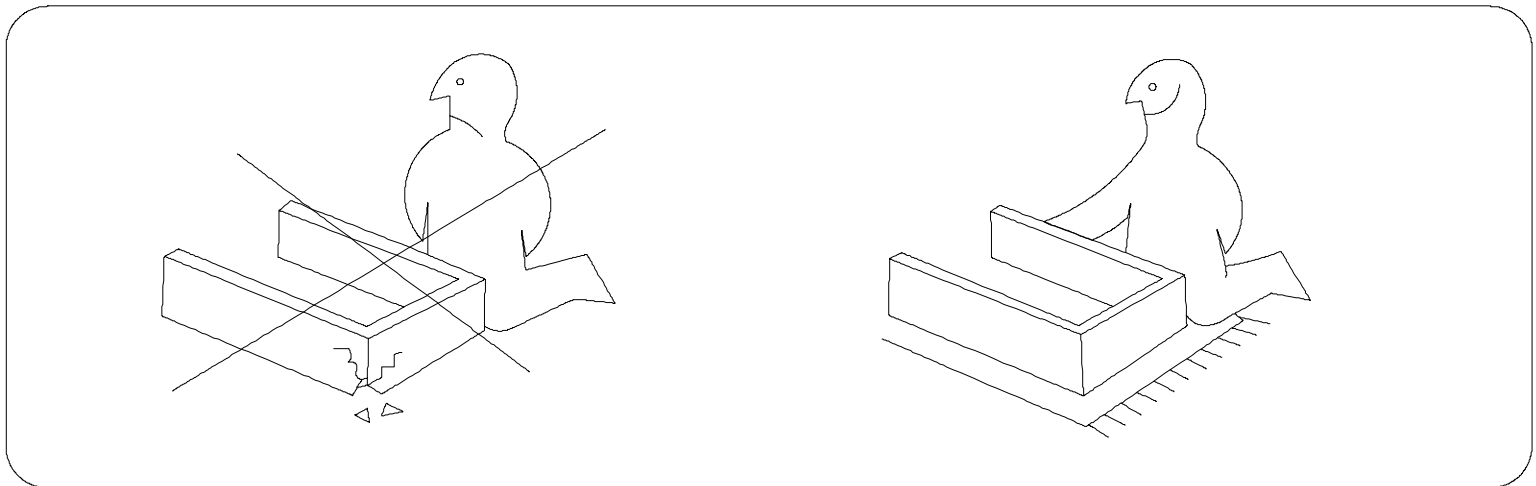
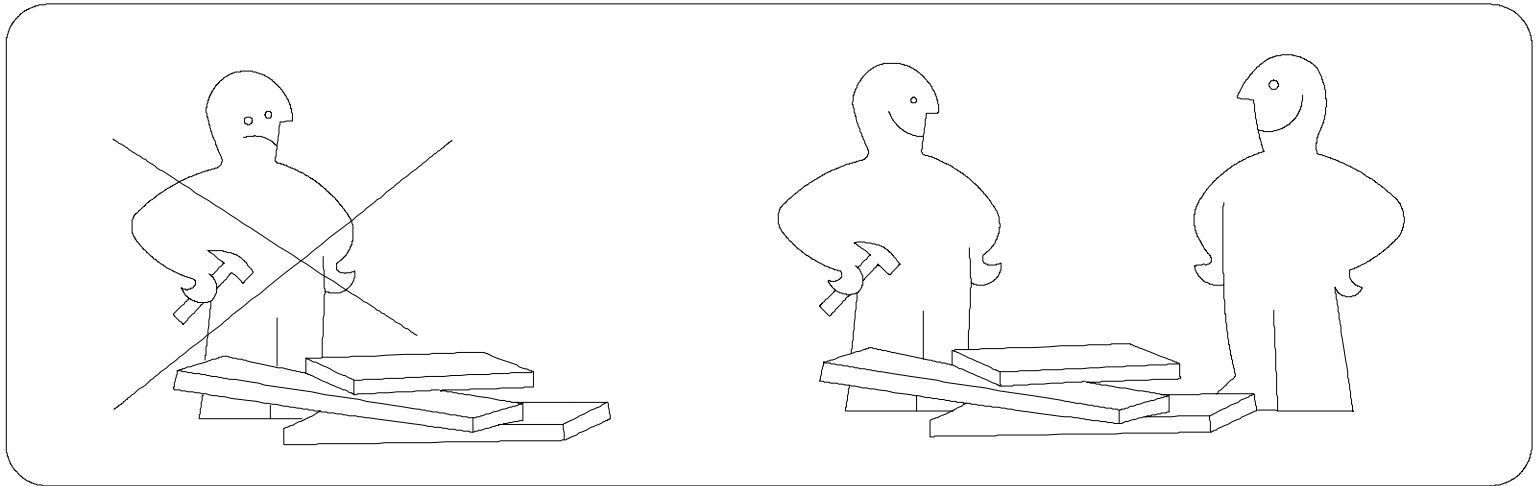
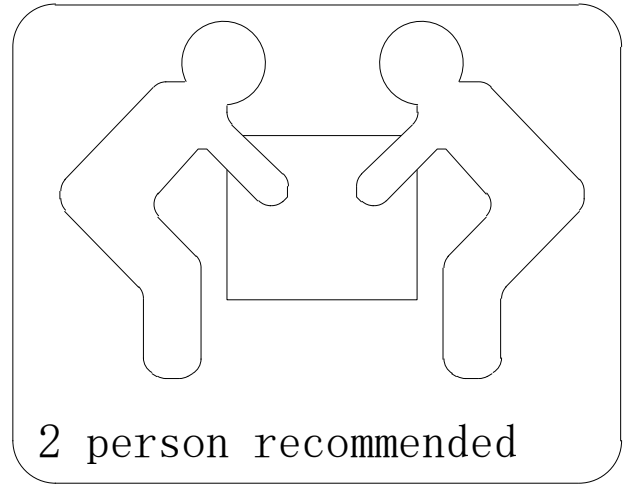
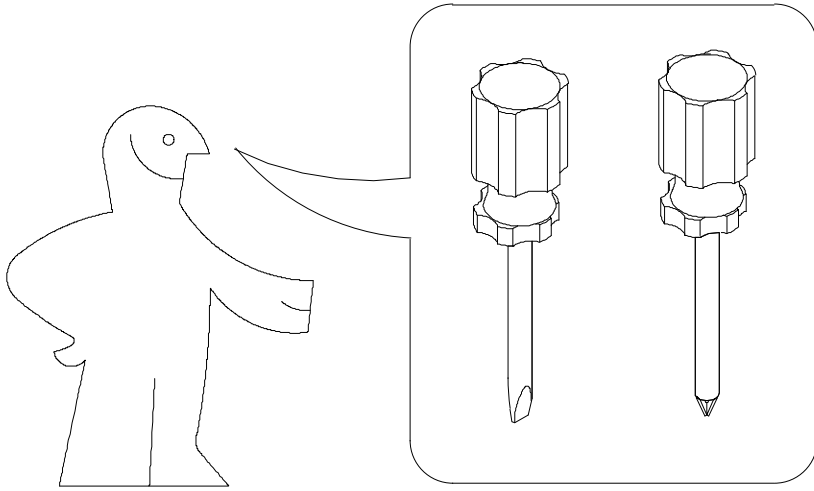

Panel No	Panel Sizes	Quantity
1	500*382*16	1
2	500*382*16	1
3	288*381*16	1
4	288*381*16	1
5	466*360*16	1
6	476*298*5	1

Panel No	Panel Sizes	Quantity
7	500*200*18	1
8	422*120*12	1
9	350*120*12	1
10	350*120*12	1
11	432*348*5	1

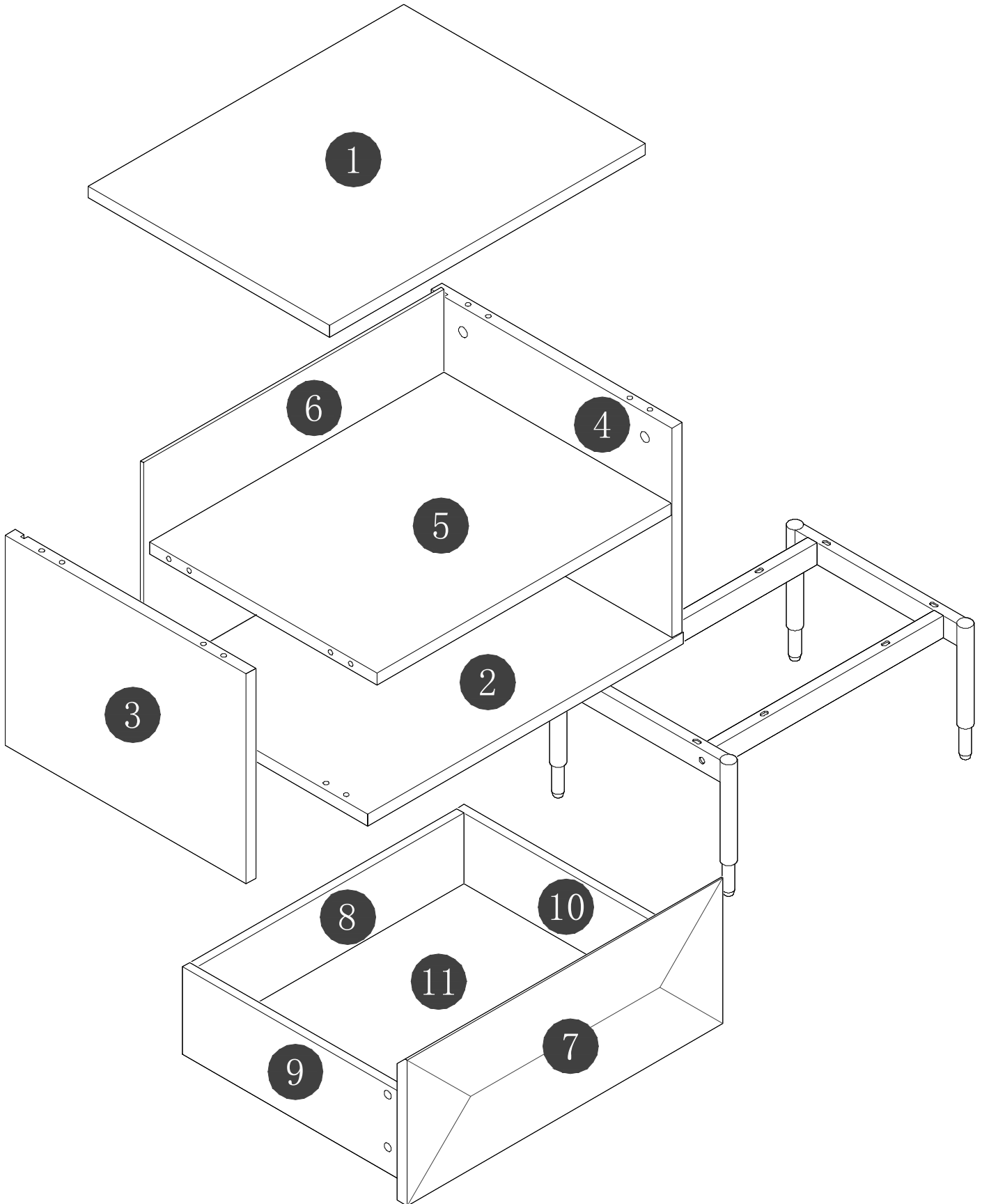

Fittings

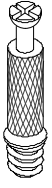

A=8



B=12

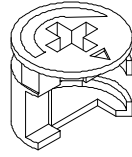

C=8



D=16

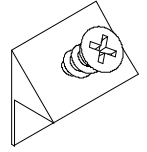

E=4

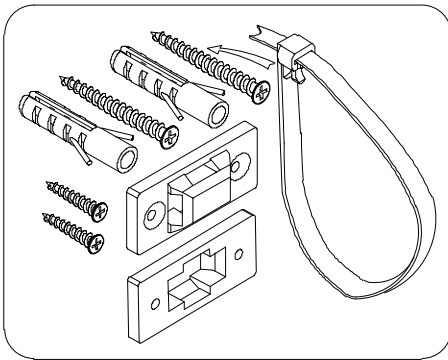

F=1



M6*25

G1=4



M6*45

G2=8

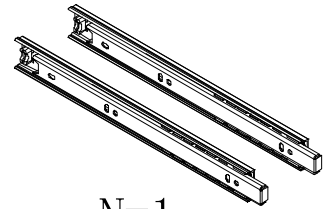

N=1



H=1

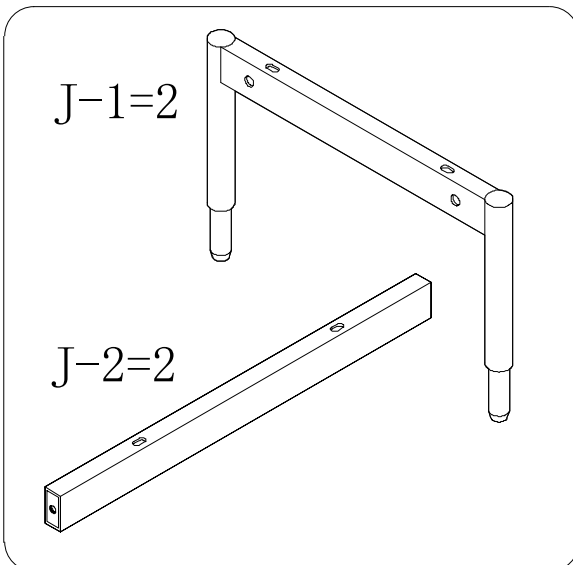

J-1=2

J-2=2



O=8



P=8

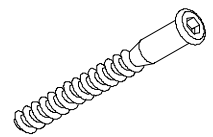

Q=4



M3. 5*12

V1=8



Z1=8



Z2=8

STEP 1

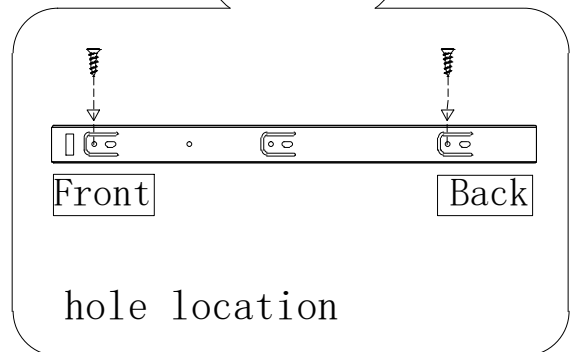
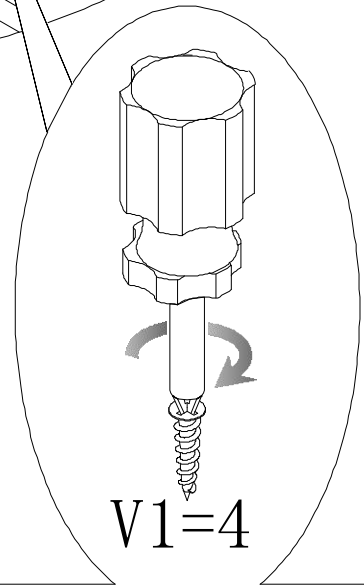
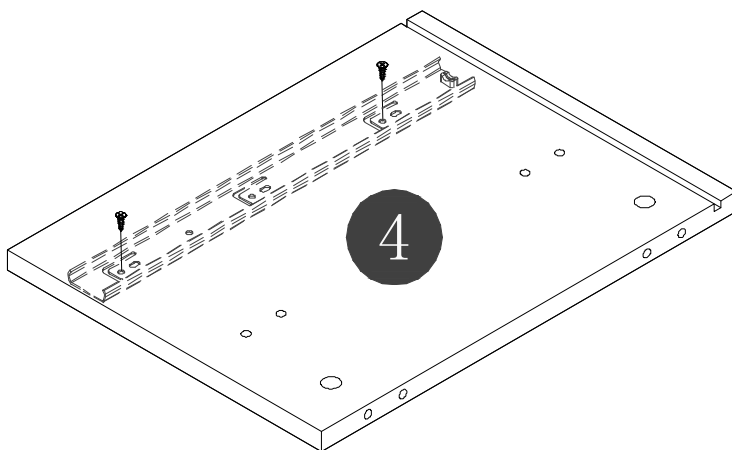
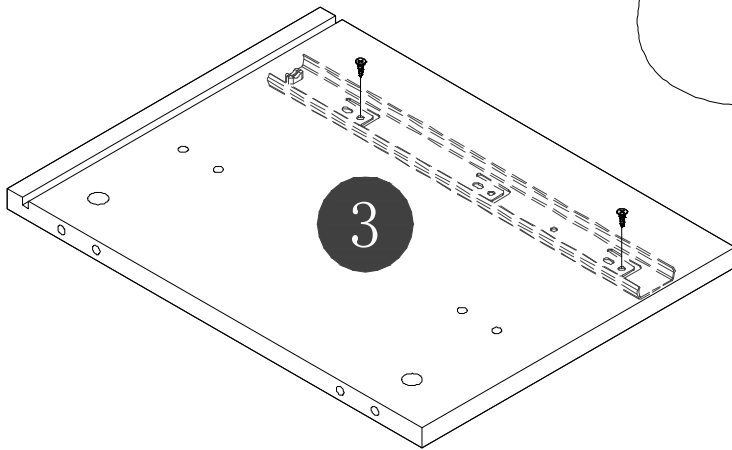
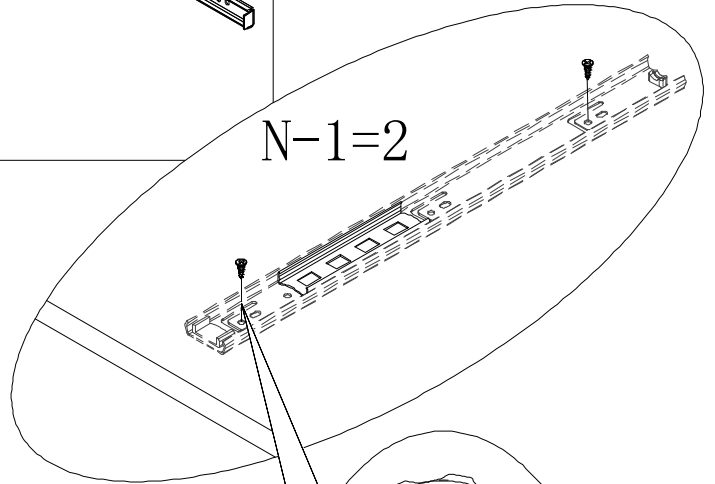
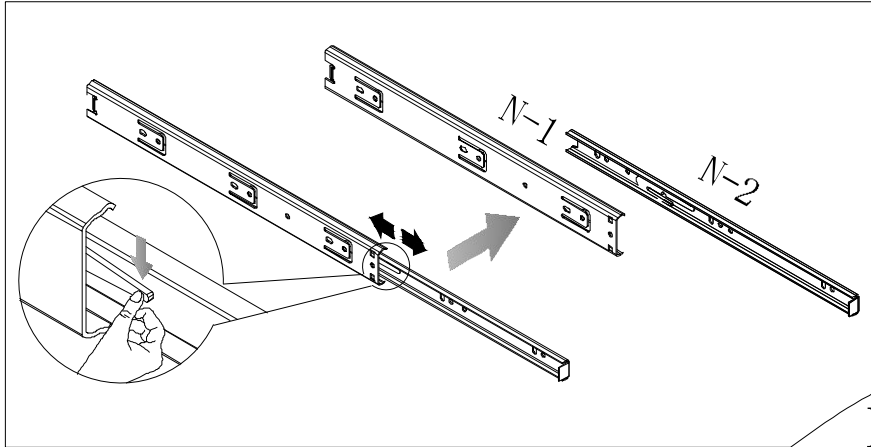

STEP 2

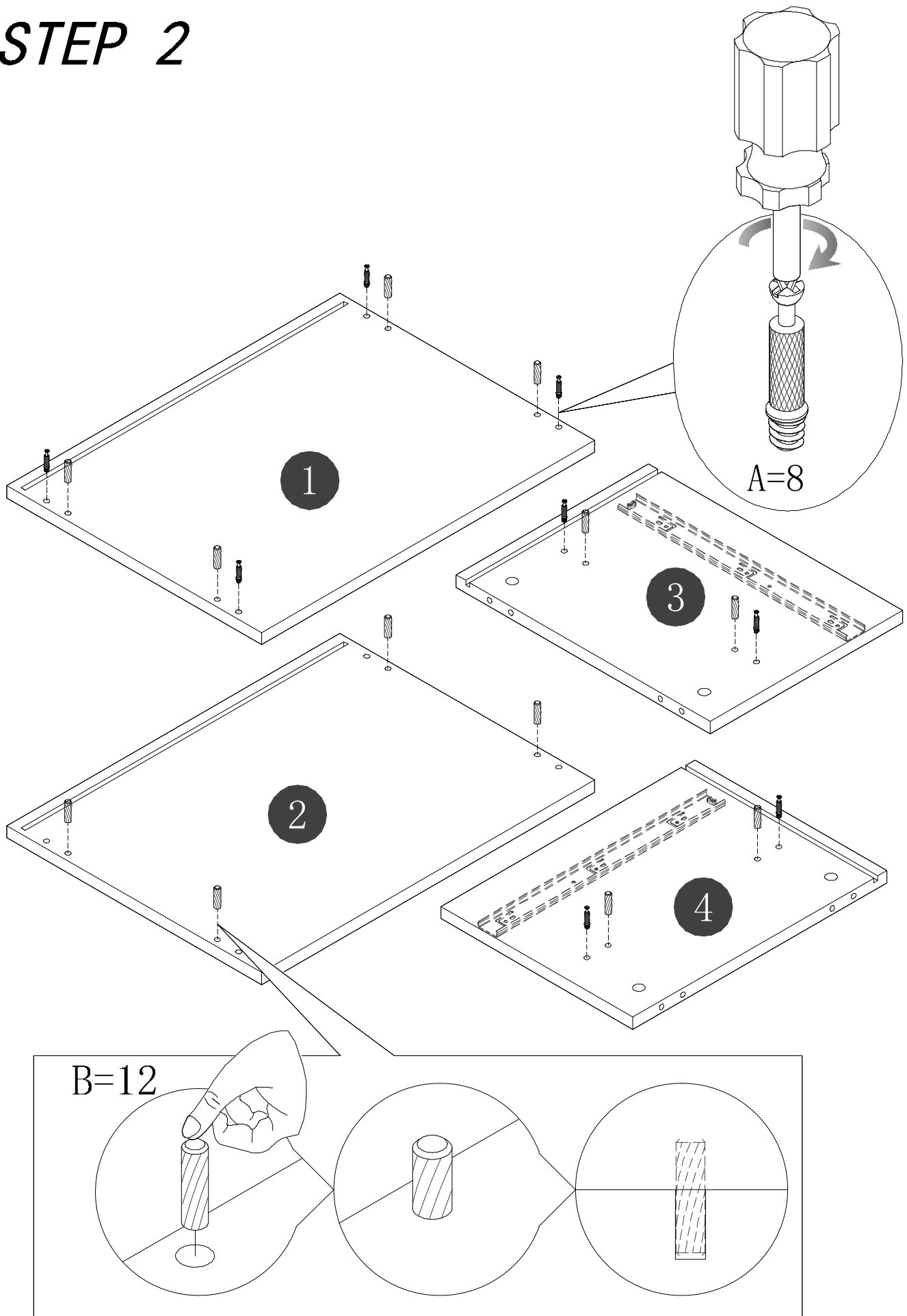

STEP 3

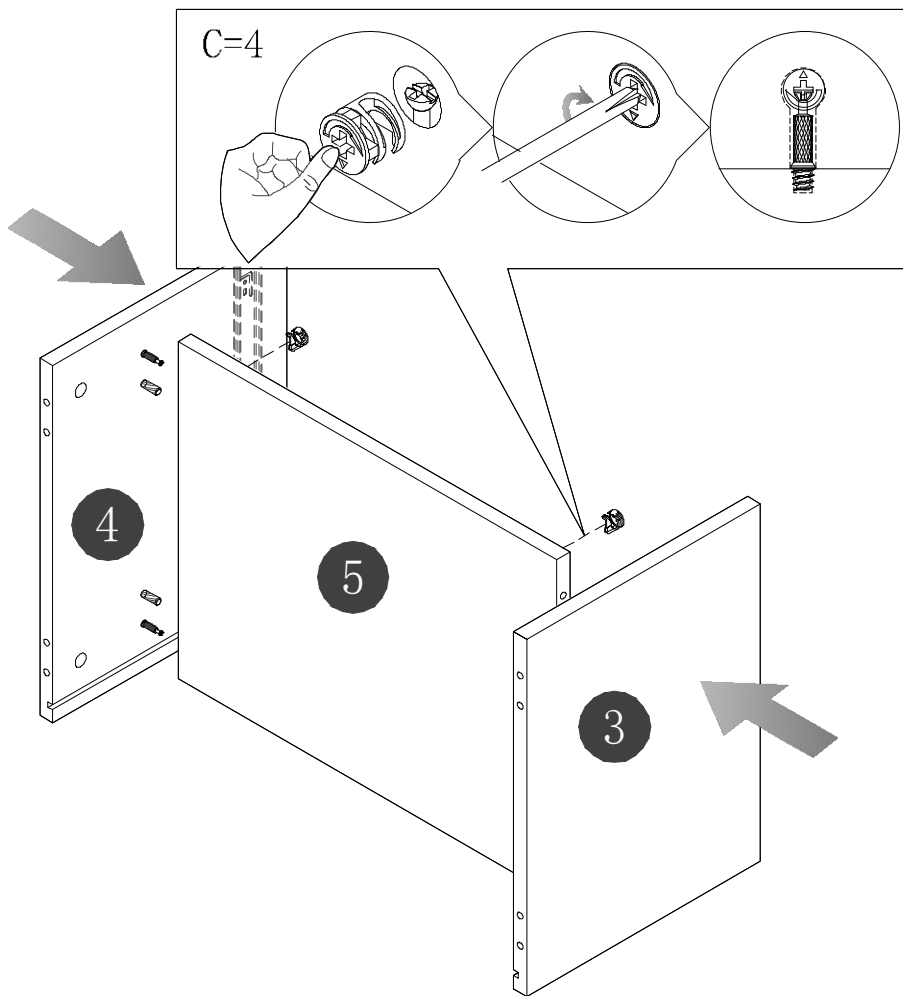

STEP 4

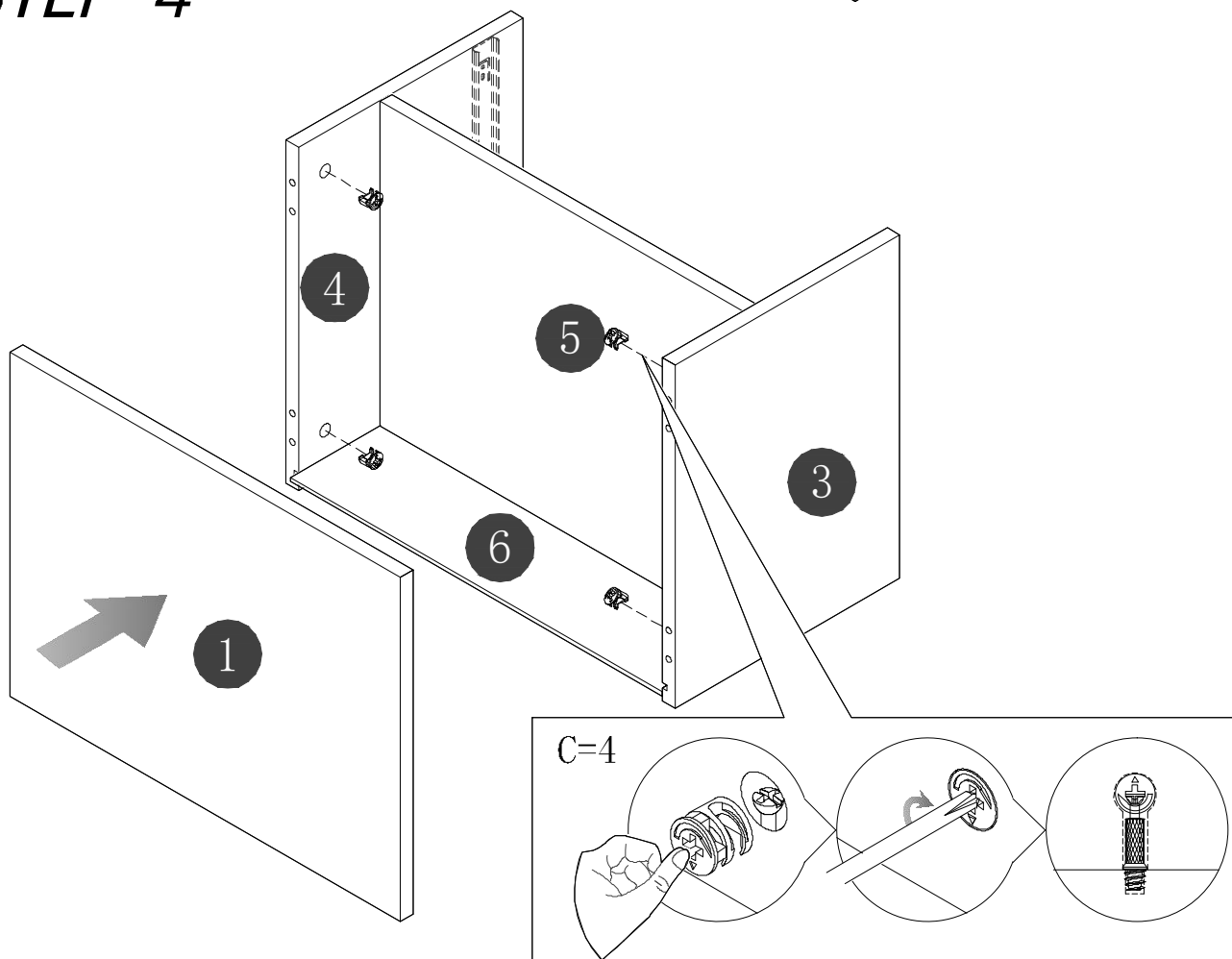

STEP 5

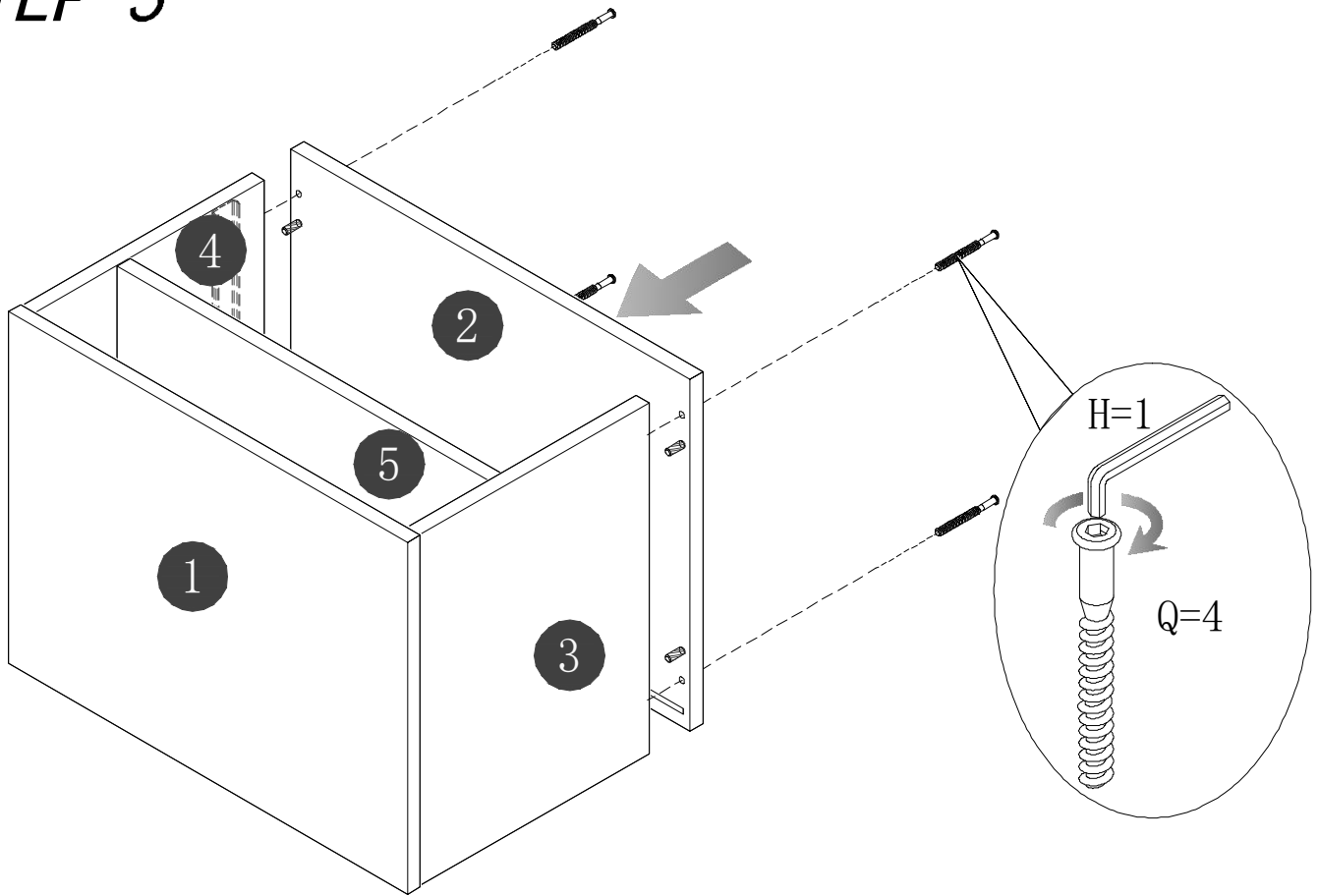

STEP 6

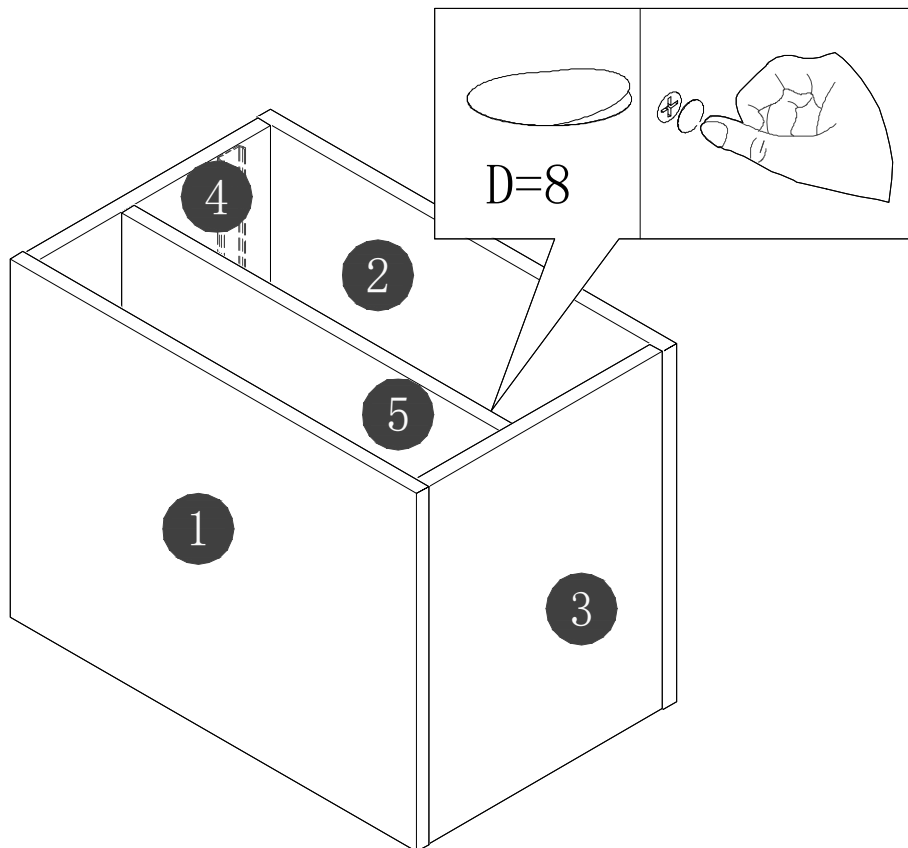

STEP 7

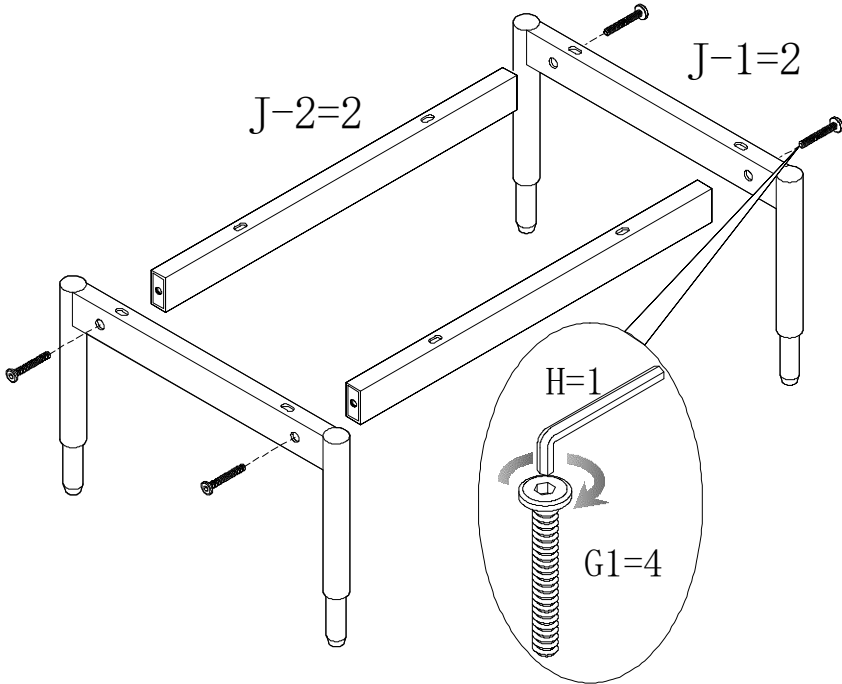

STEP 8

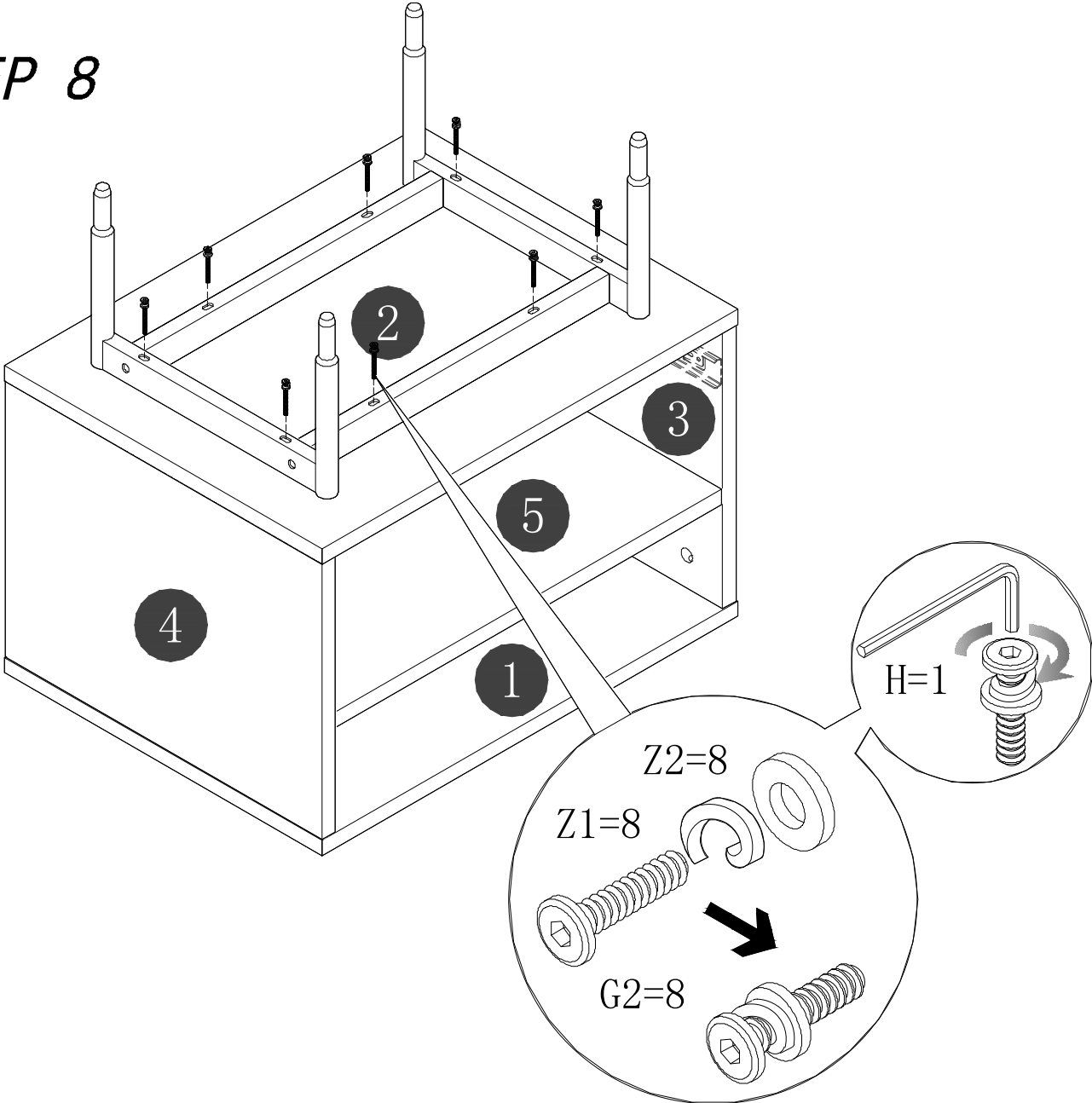

STEP 9

9-1

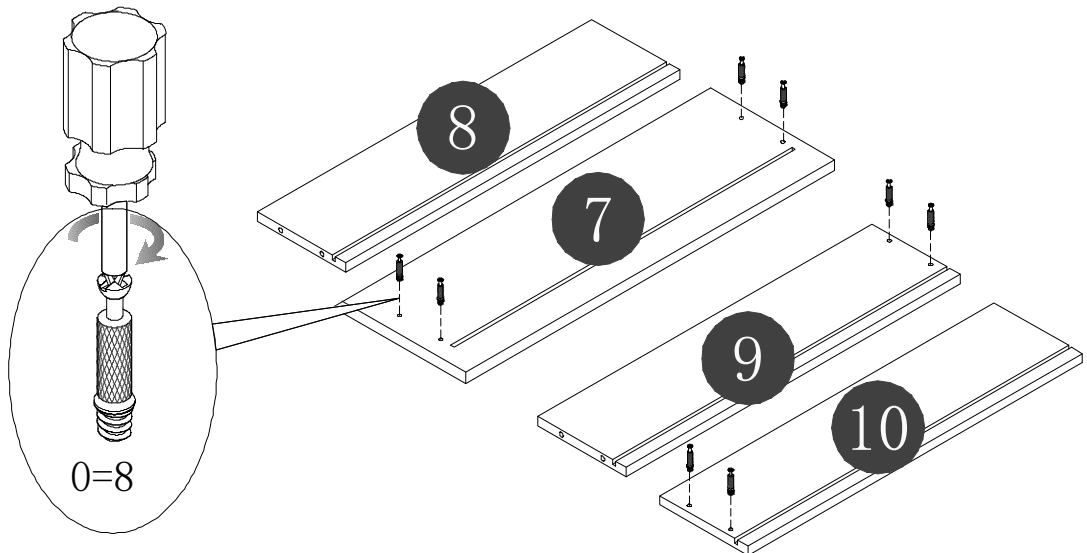

9-2

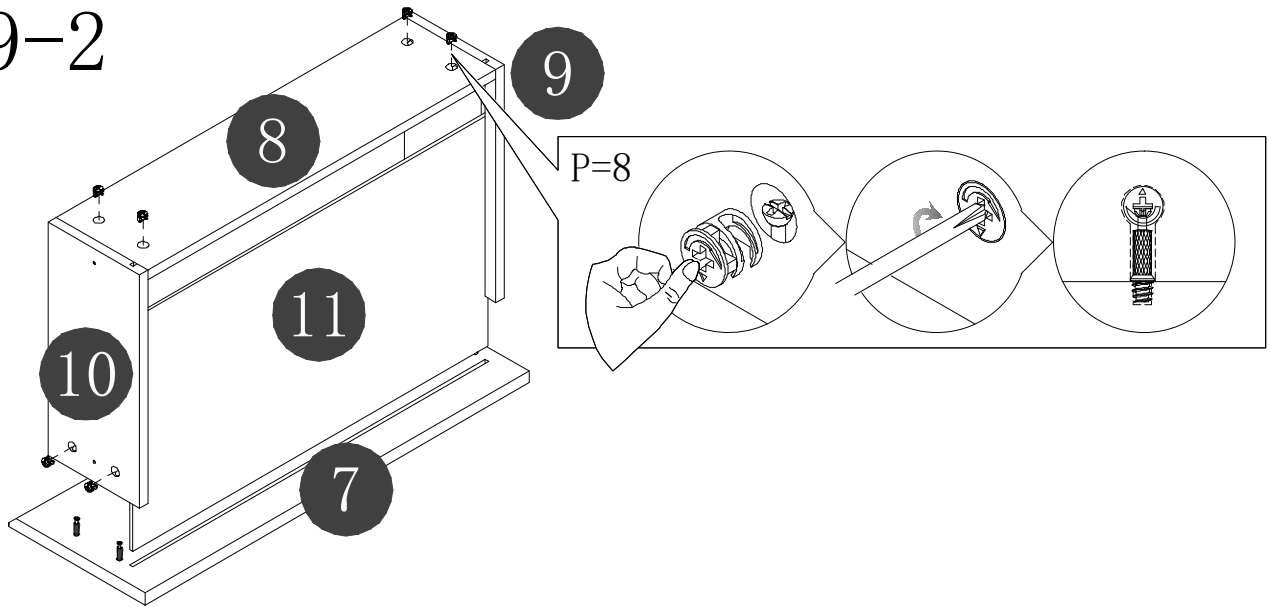

9-3

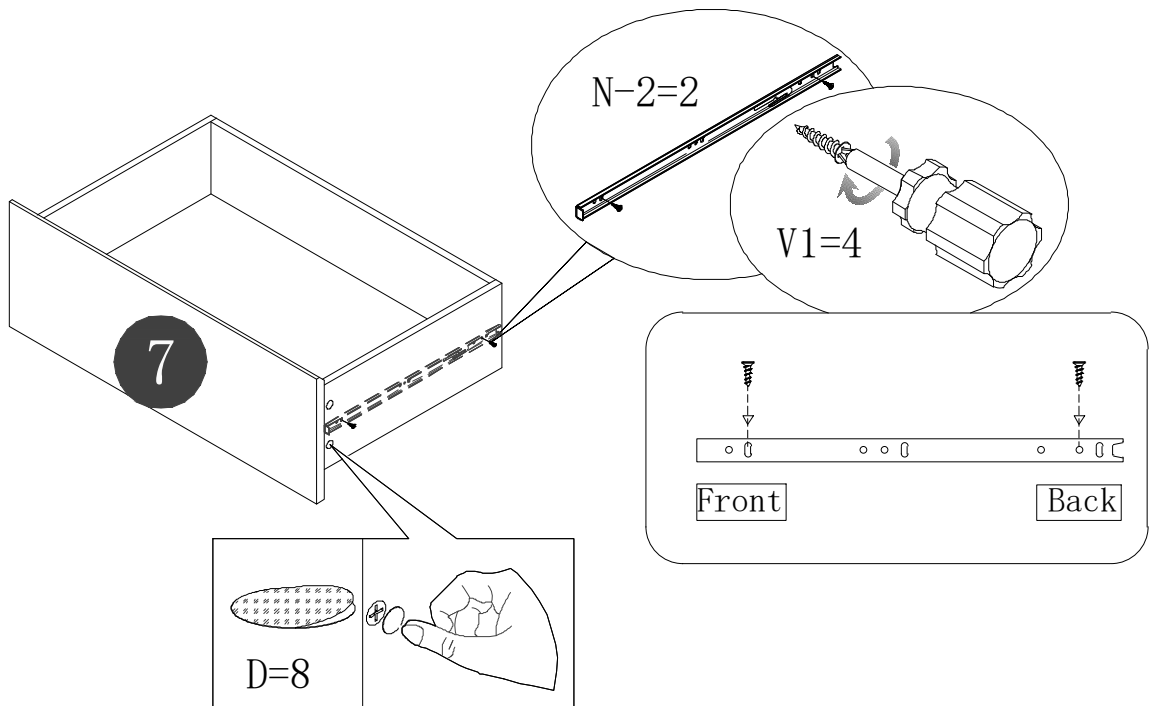

STEP 10

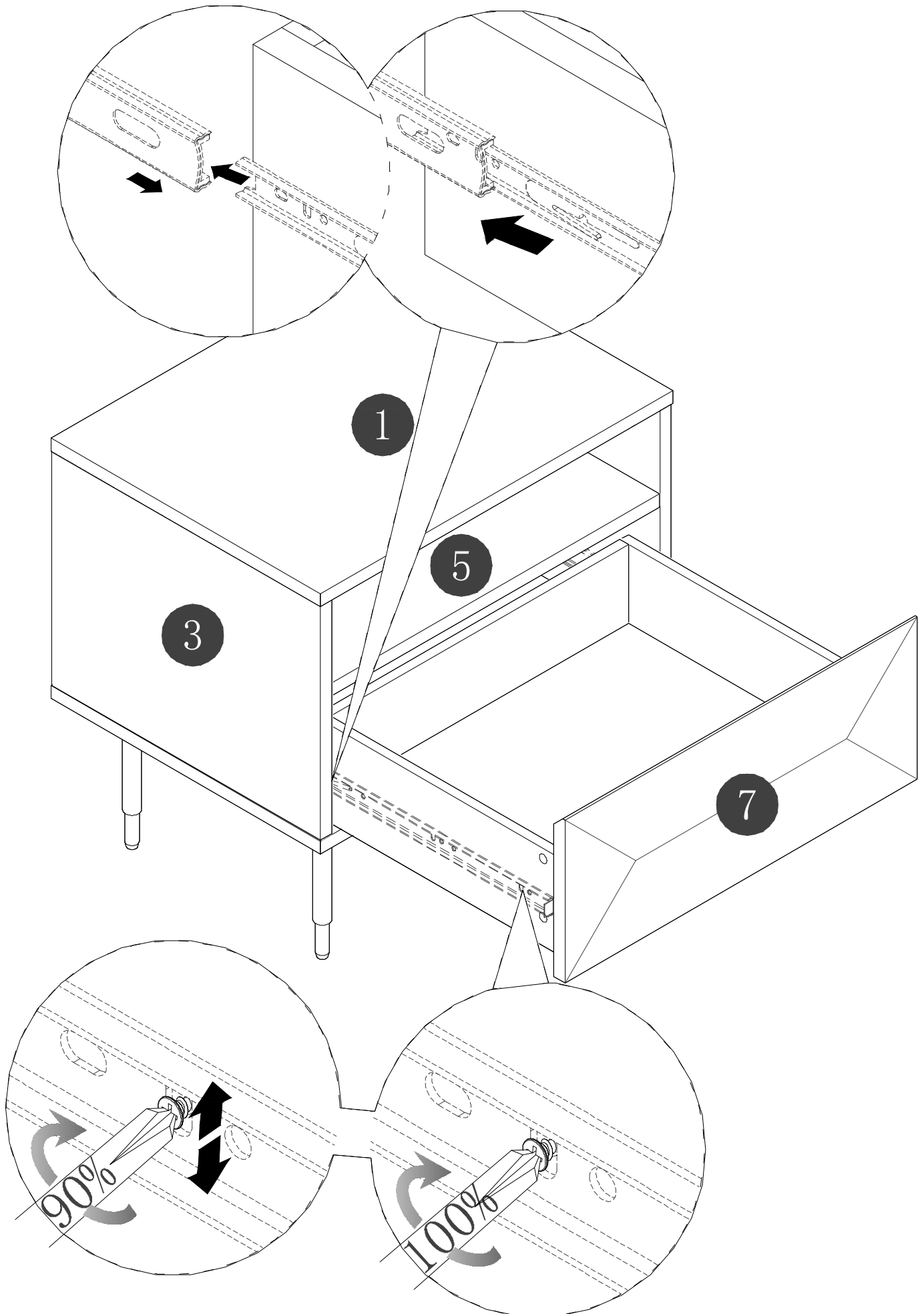

STEP 11

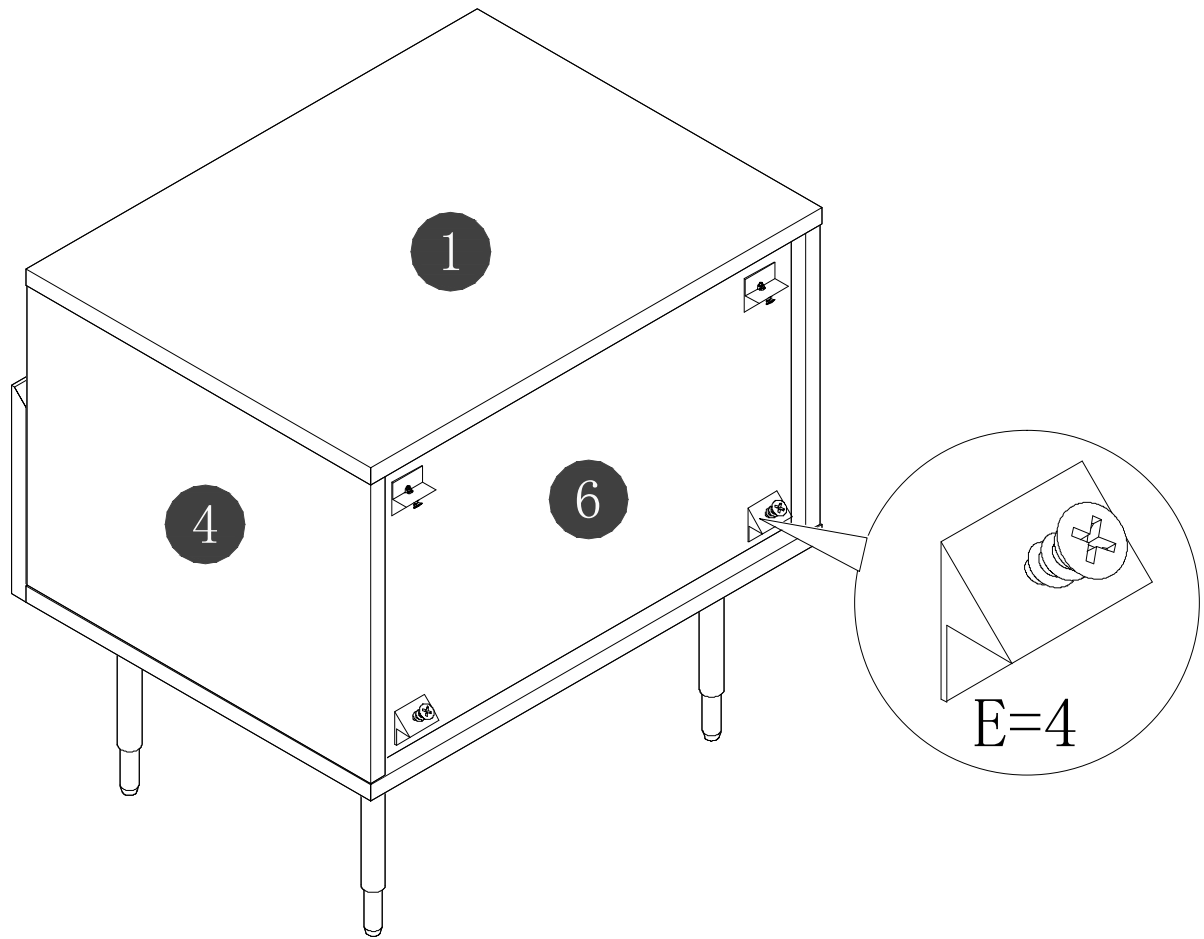

STEP 12

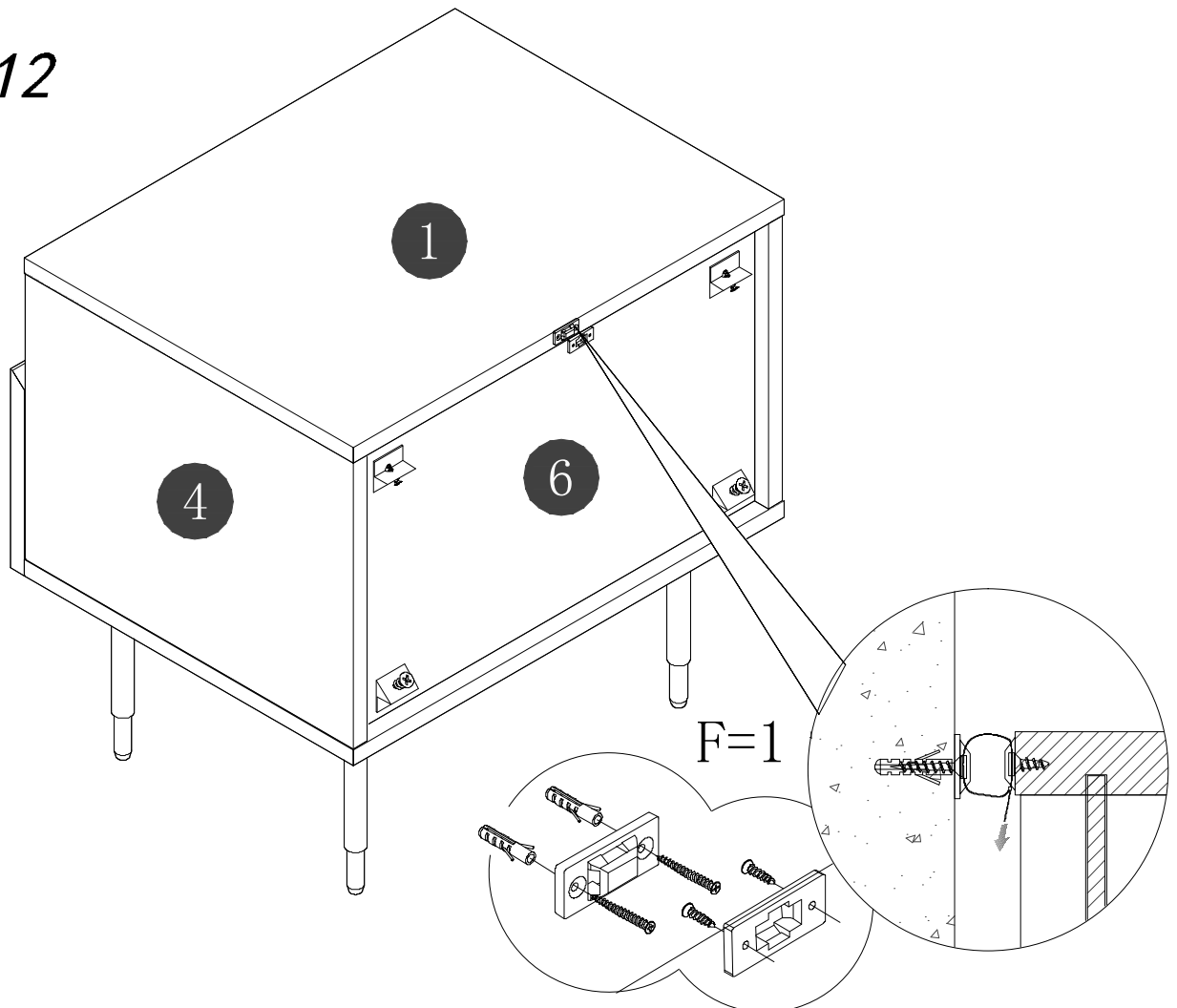

STEP 13



Finish

耐特床头柜邮购包装

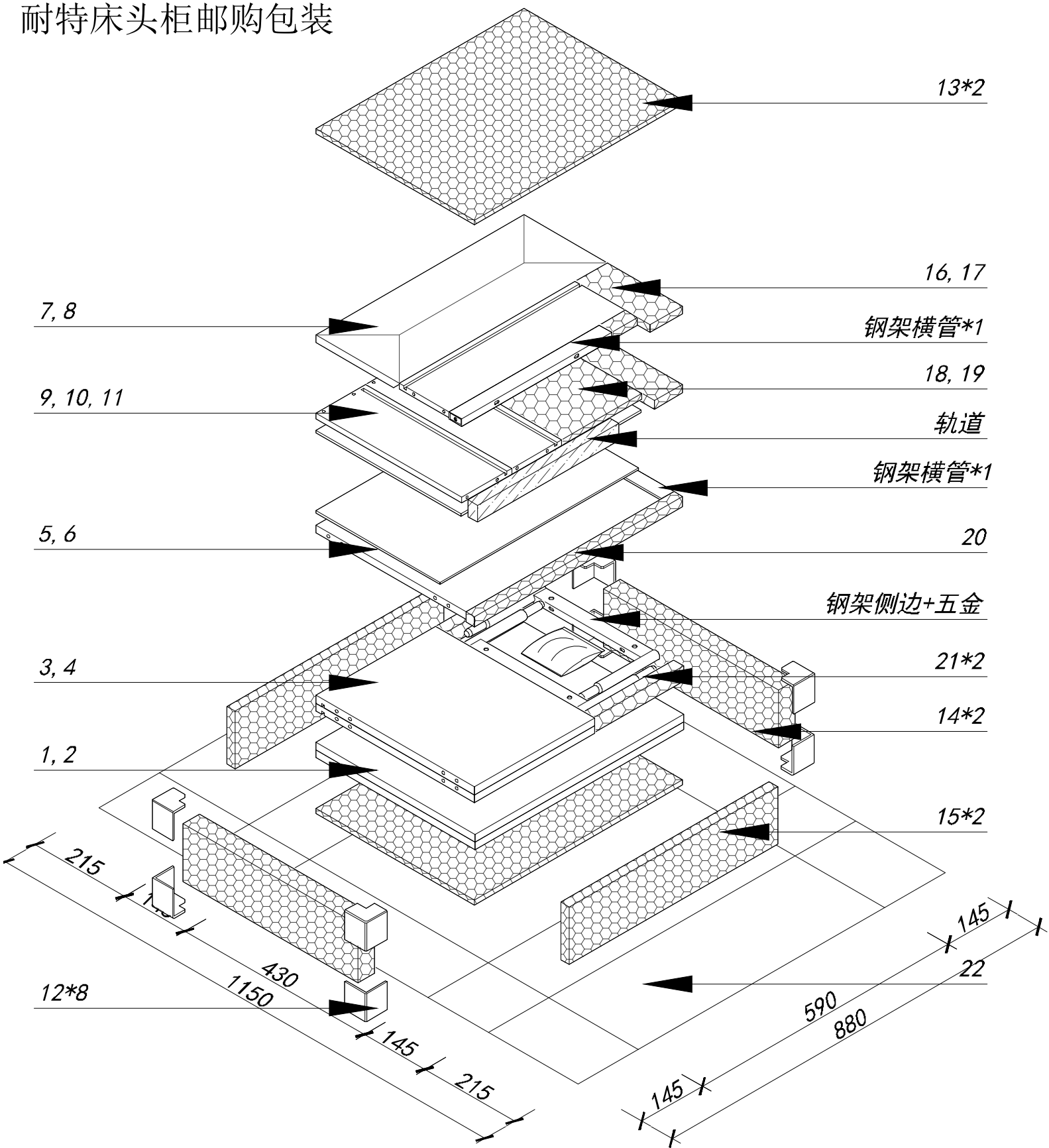

Panel No		Panel Sizes	Quantity
12	护角	50*50*50	8
13	泡沫	500*380*10	2
14	泡沫	420*135*40	2
15	泡沫	500*135*20	2
16	泡沫	180*78*15	1
17	泡沫	61*30*15	1
18	泡沫	350*190*10	1

Panel No		Panel Sizes	Quantity
19	泡沫	380*68*15	1
20	泡沫	500*20*20	1
21	泡沫	210*30*25	2
22	纸盒	内径590*430*145	1