

Assembly Instruction

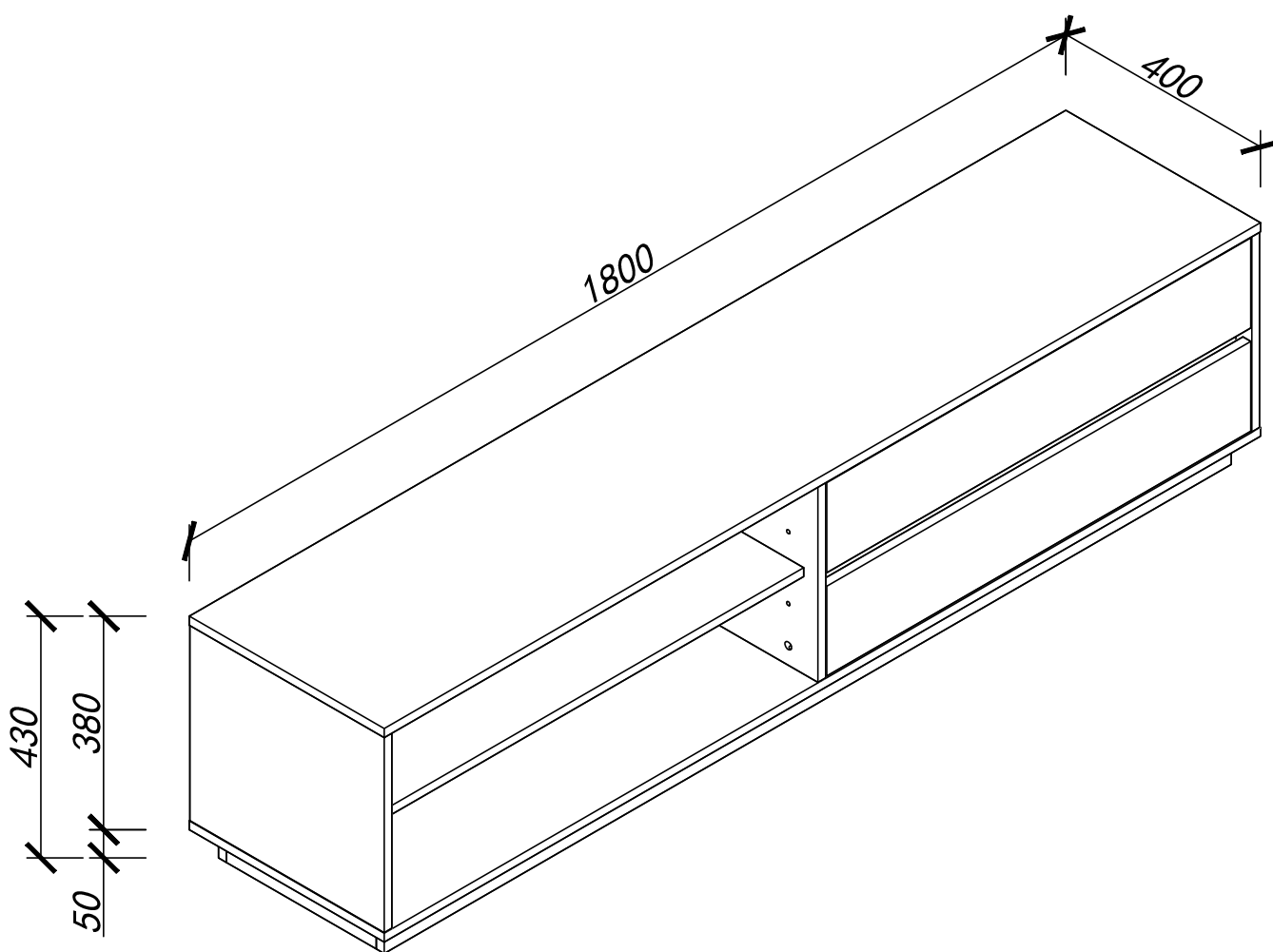

Panel No	Panel Sizes	Quantity	Panel No	Panel Sizes	Quantity
1	1800*400*16	1	10	871*160*16	1
2	1800*400*16	1	11	871*160*16	1
3	348*399*16	1	12	825*80*12	2
4	348*399*16	1	13	338*100*12	2
5	348*399*16	1	14	350*80*12	2
6	885*358*5	1	15	350*80*12	2
7	885*358*5	1	16	835*348*5	2
8	872*350*16	1	17	1740*50*16	2
9	875*60*16	1	18	308*50*16	3

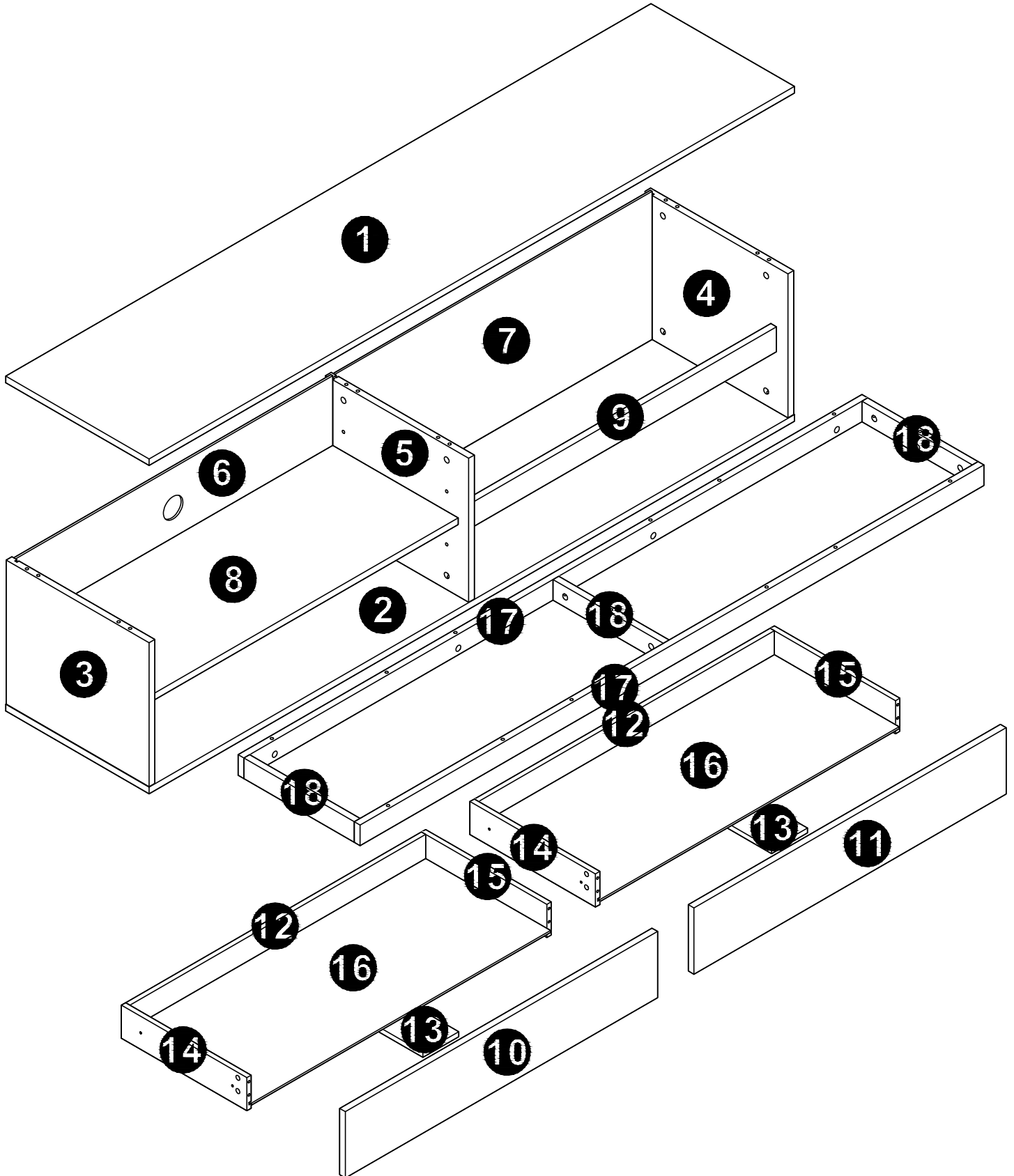

Fittings



A=31

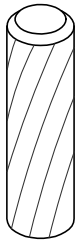

B=18

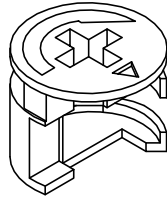

C=31



D=51

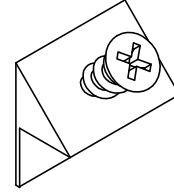

E=8

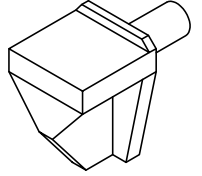

L=4

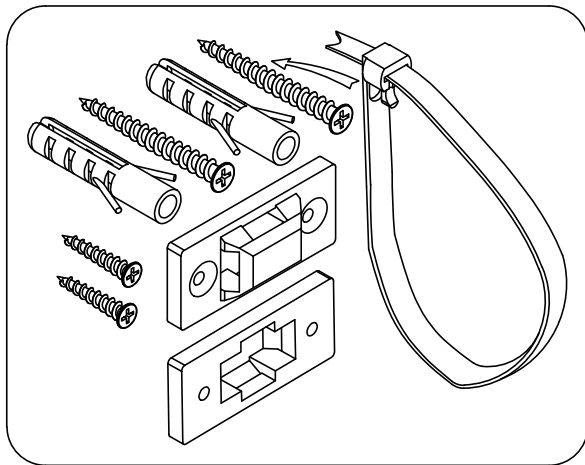

F=1

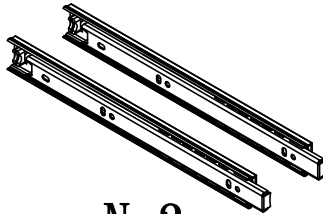

N=2



O=20



P=20



M3. 5*12

V1=16

Tools Needed

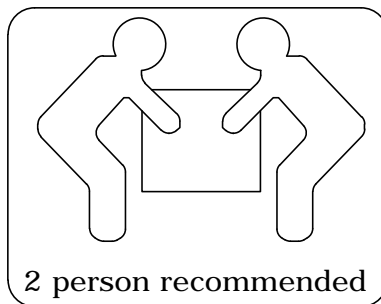
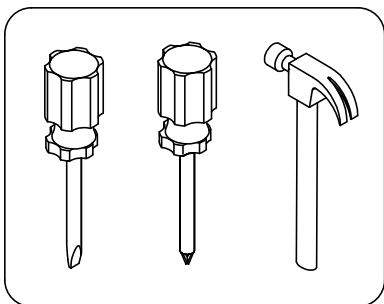

STEP 1

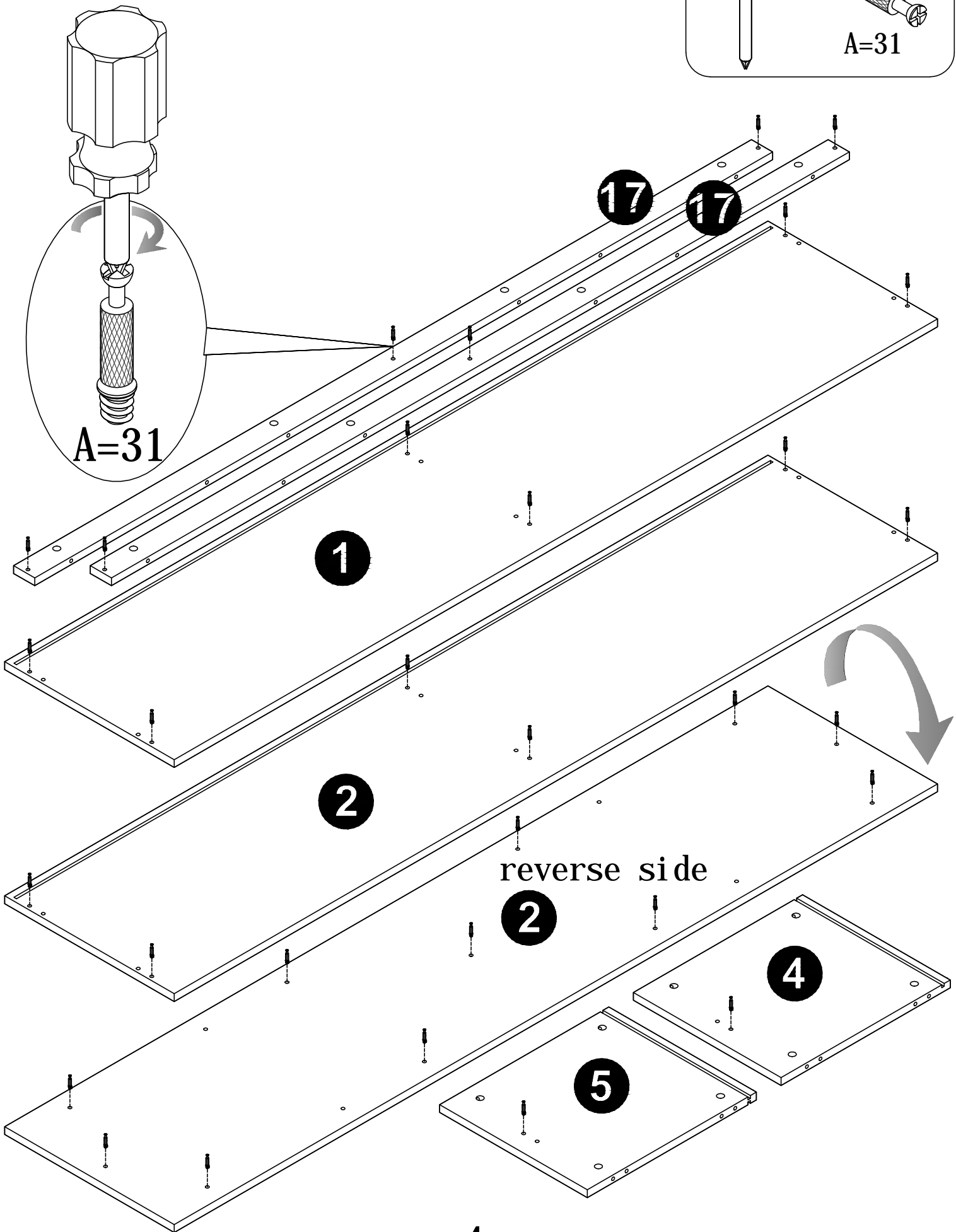
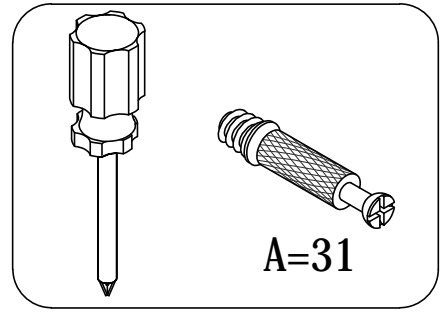

STEP 2

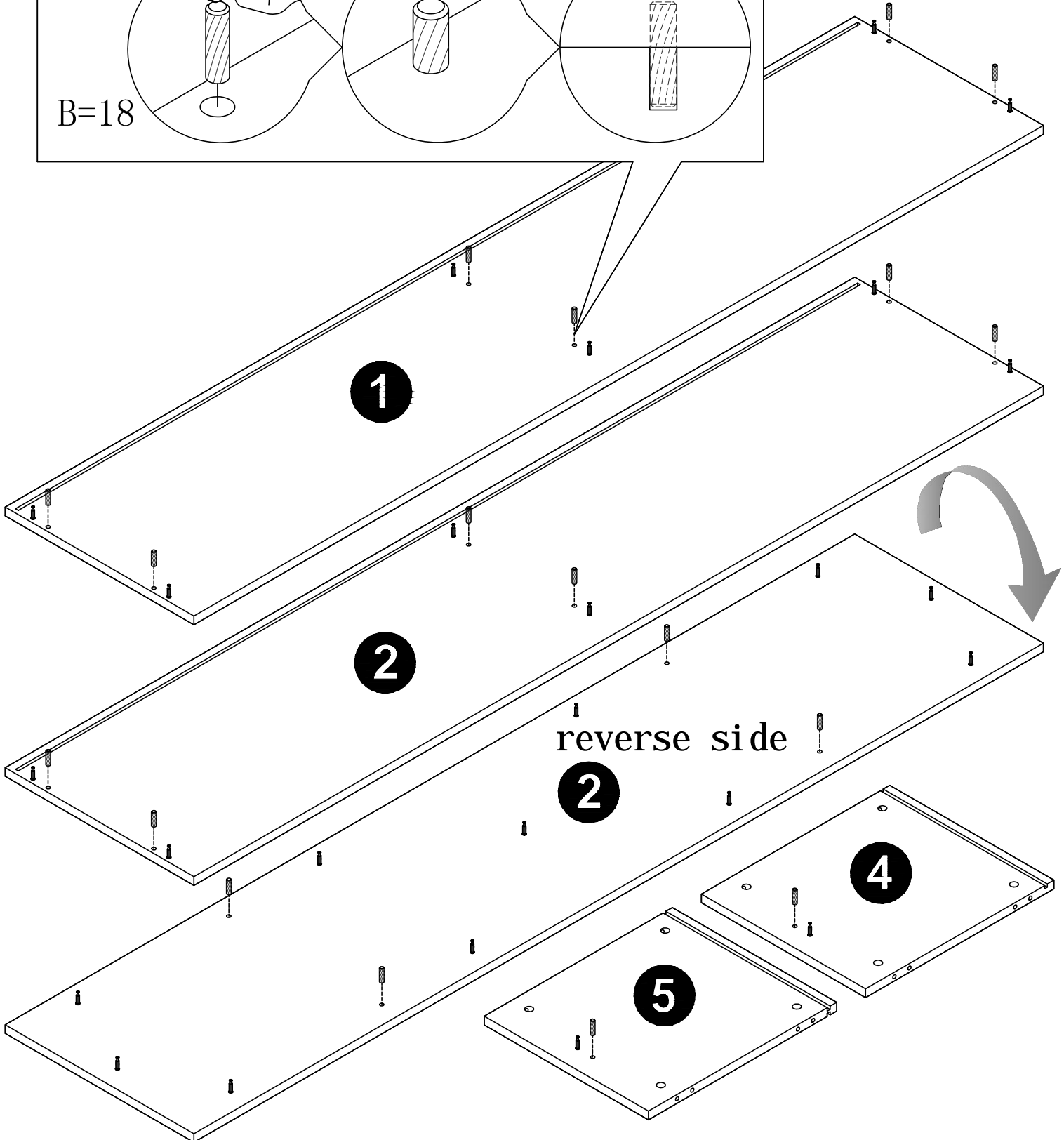
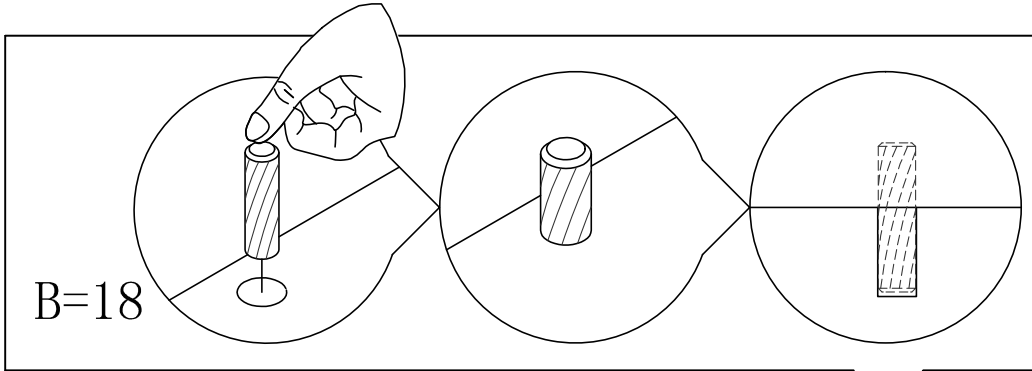
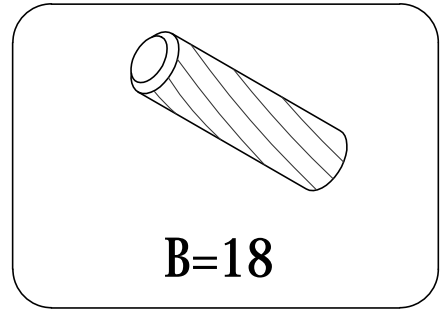

STEP 3 Separate the drawer runners

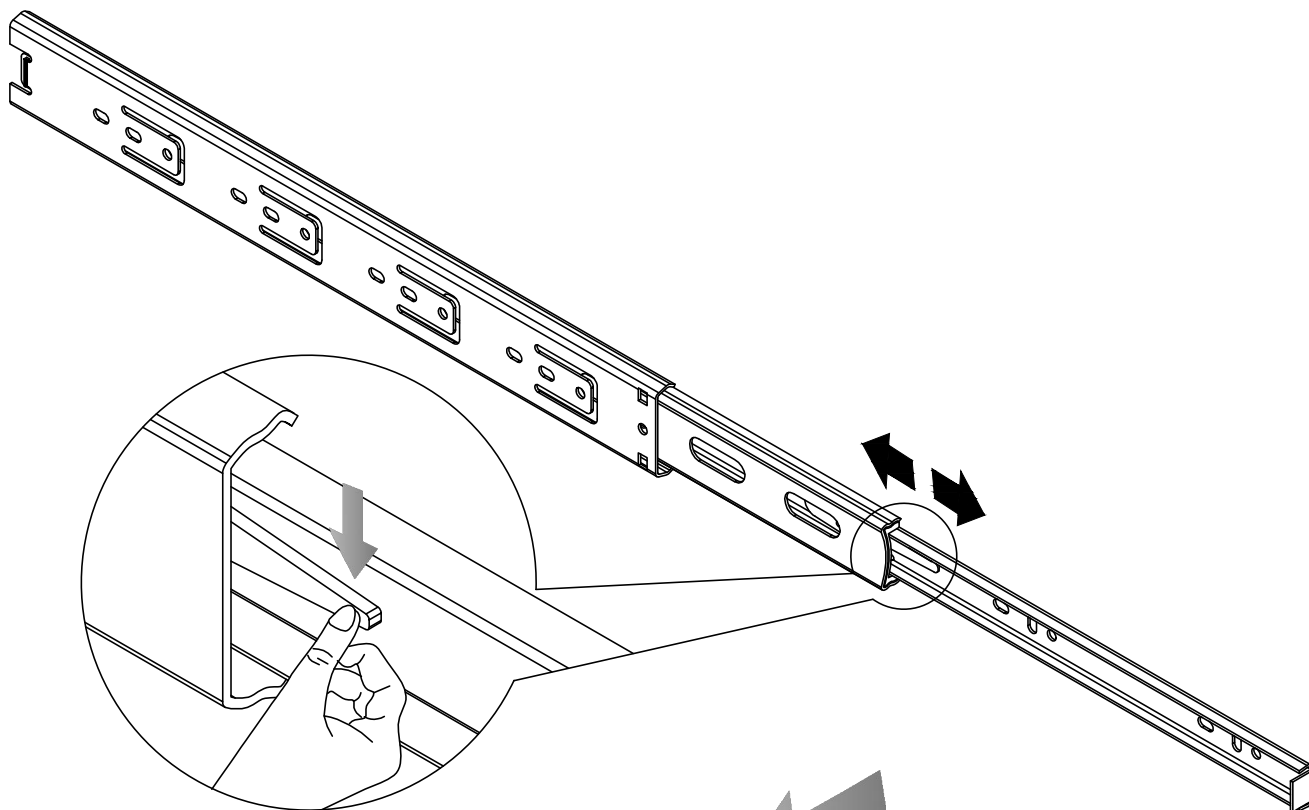

Push down the small lever and pull the two pieces apart

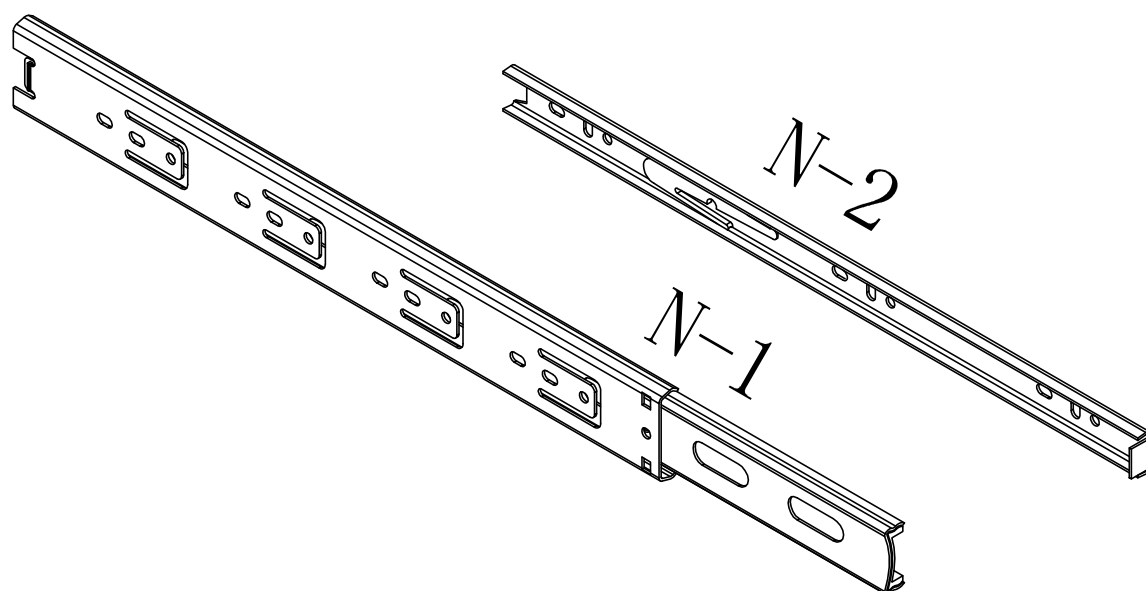

STEP 4

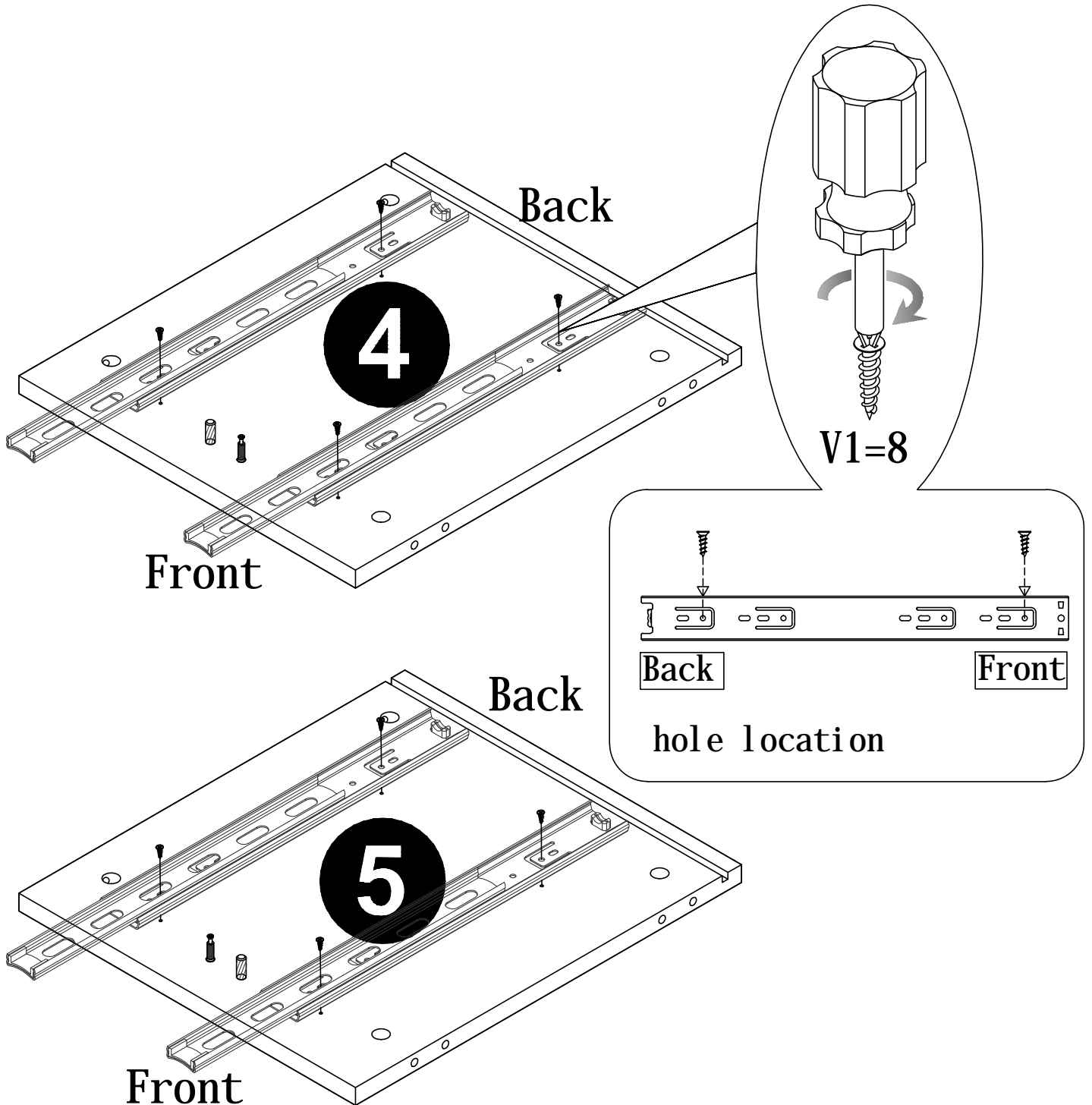
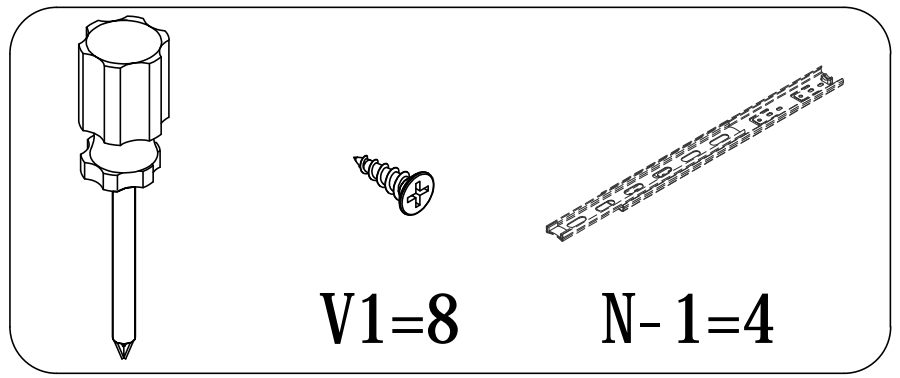

STEP 5

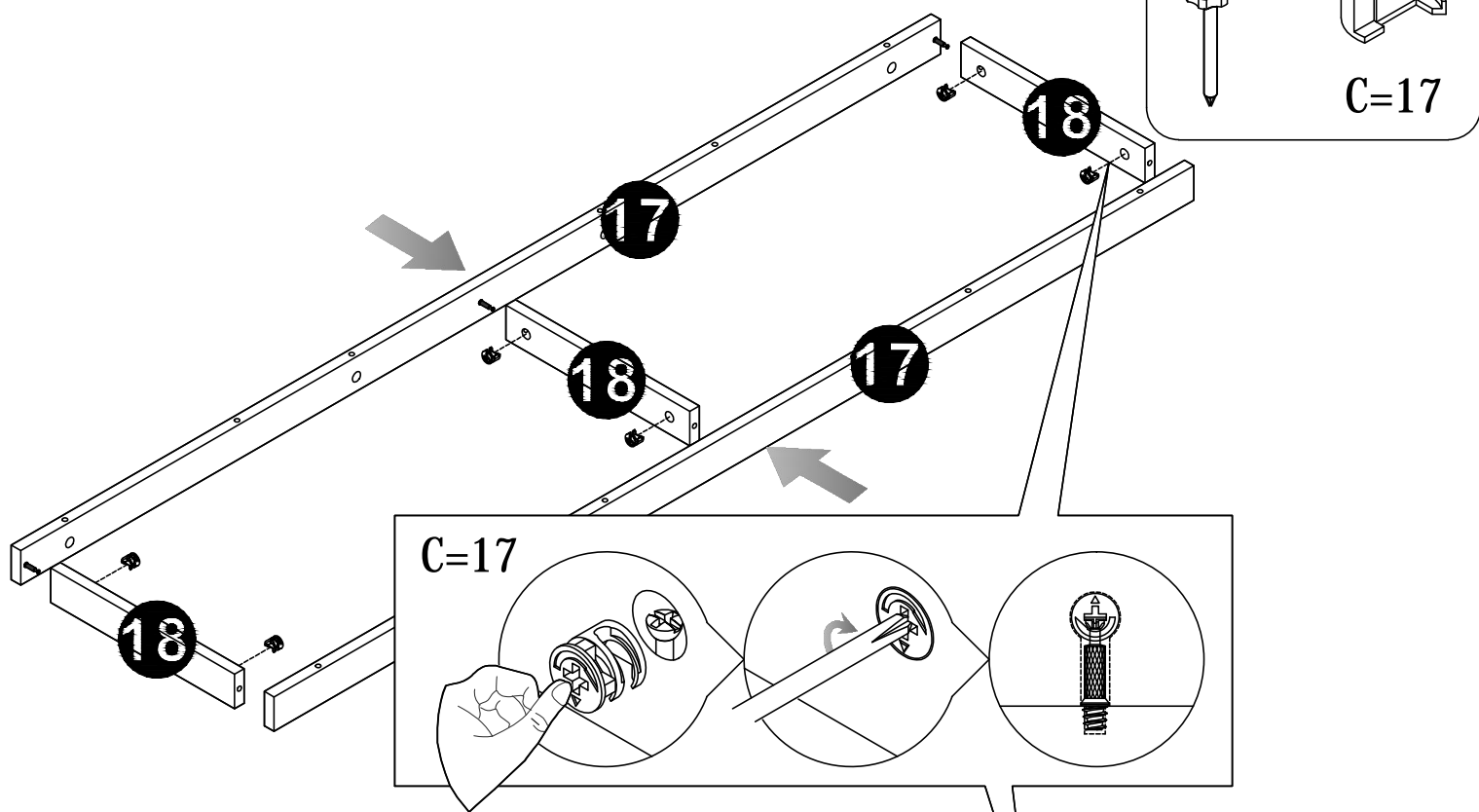

STEP 6

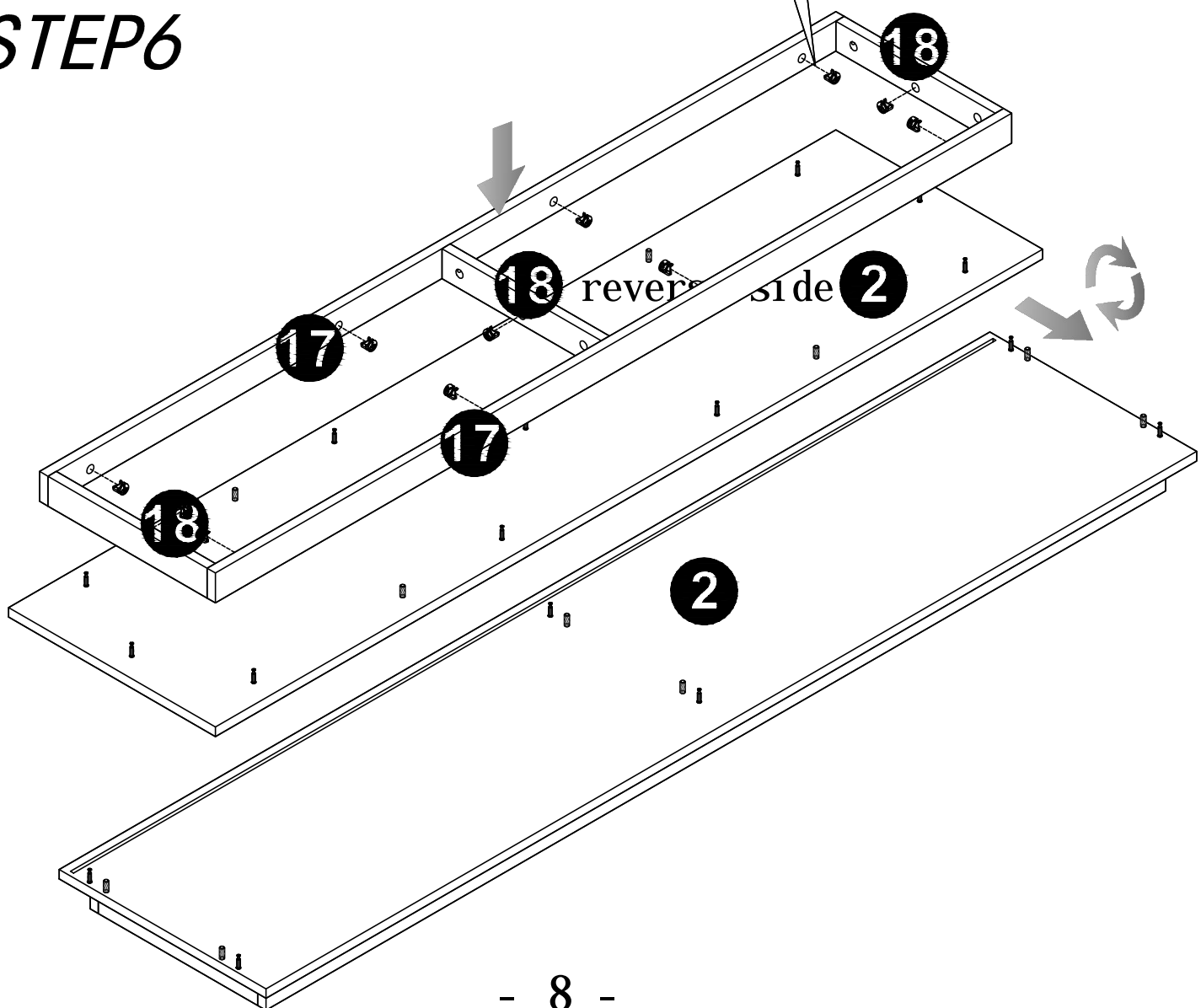

STEP 7

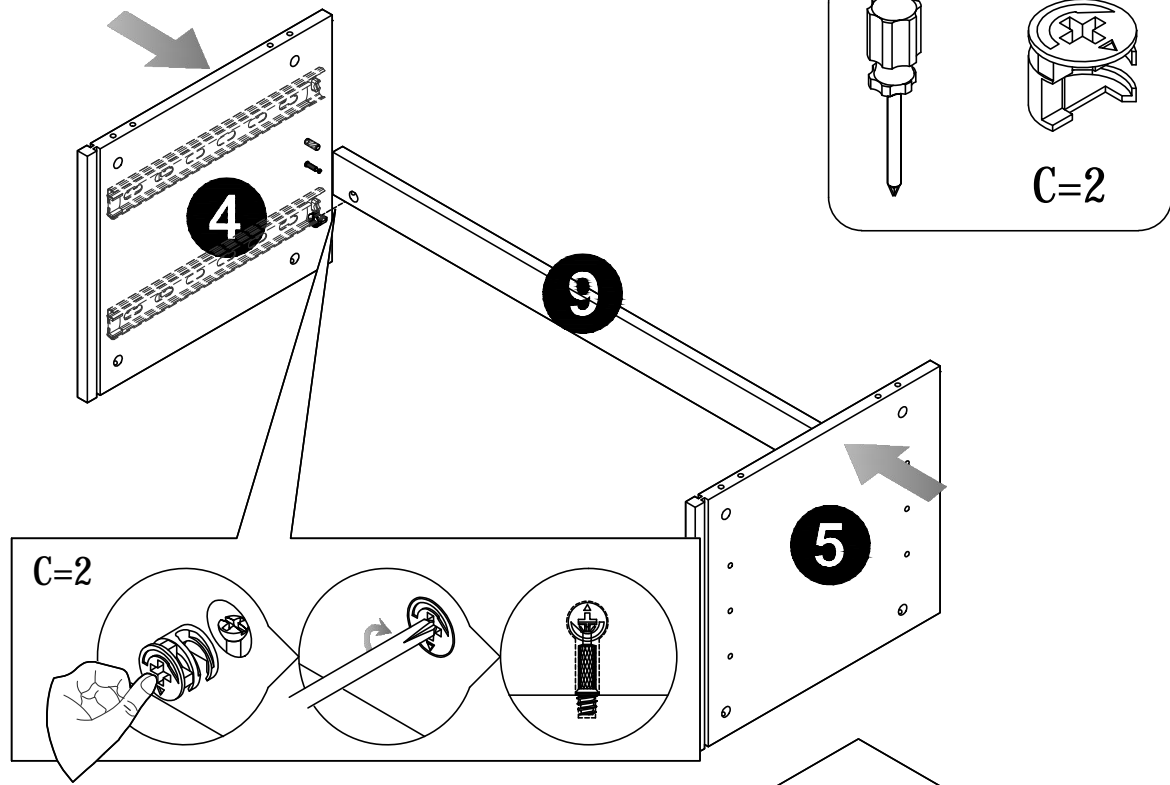

STEP 8

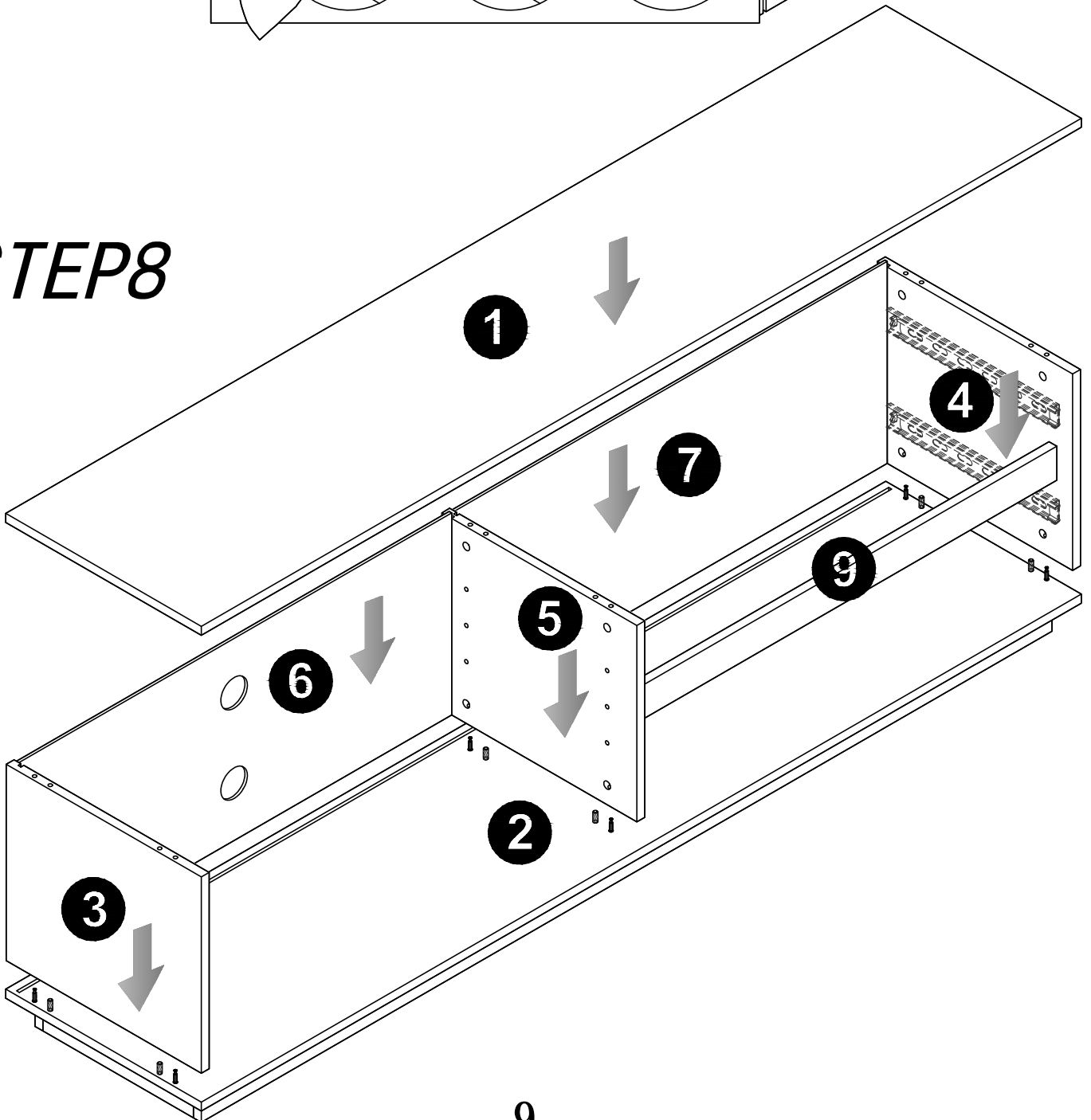

STEP 9

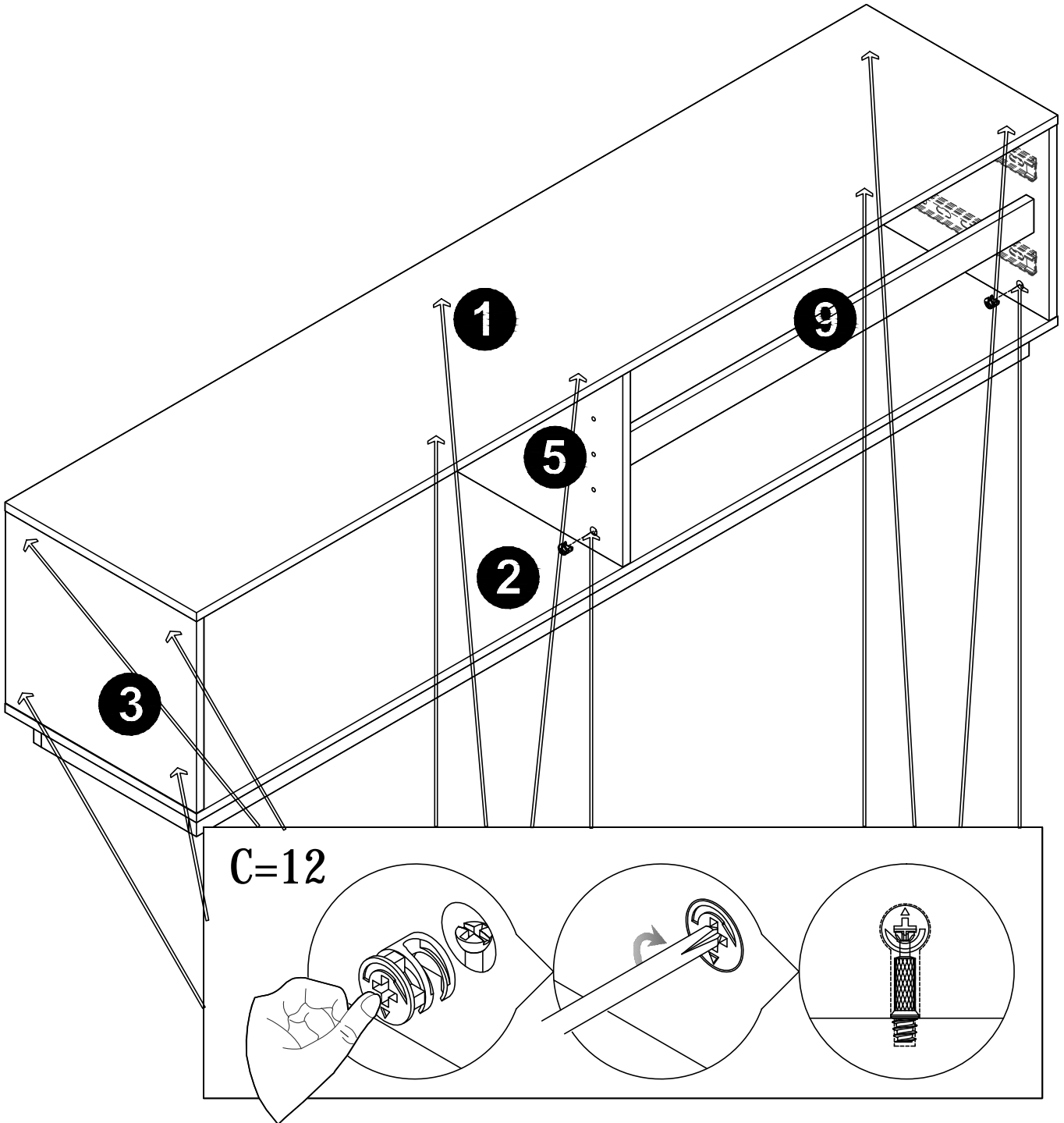
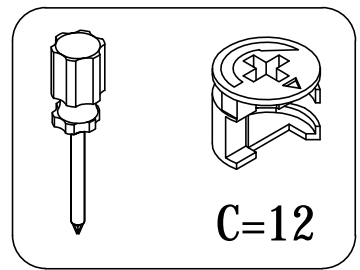

STEP 10

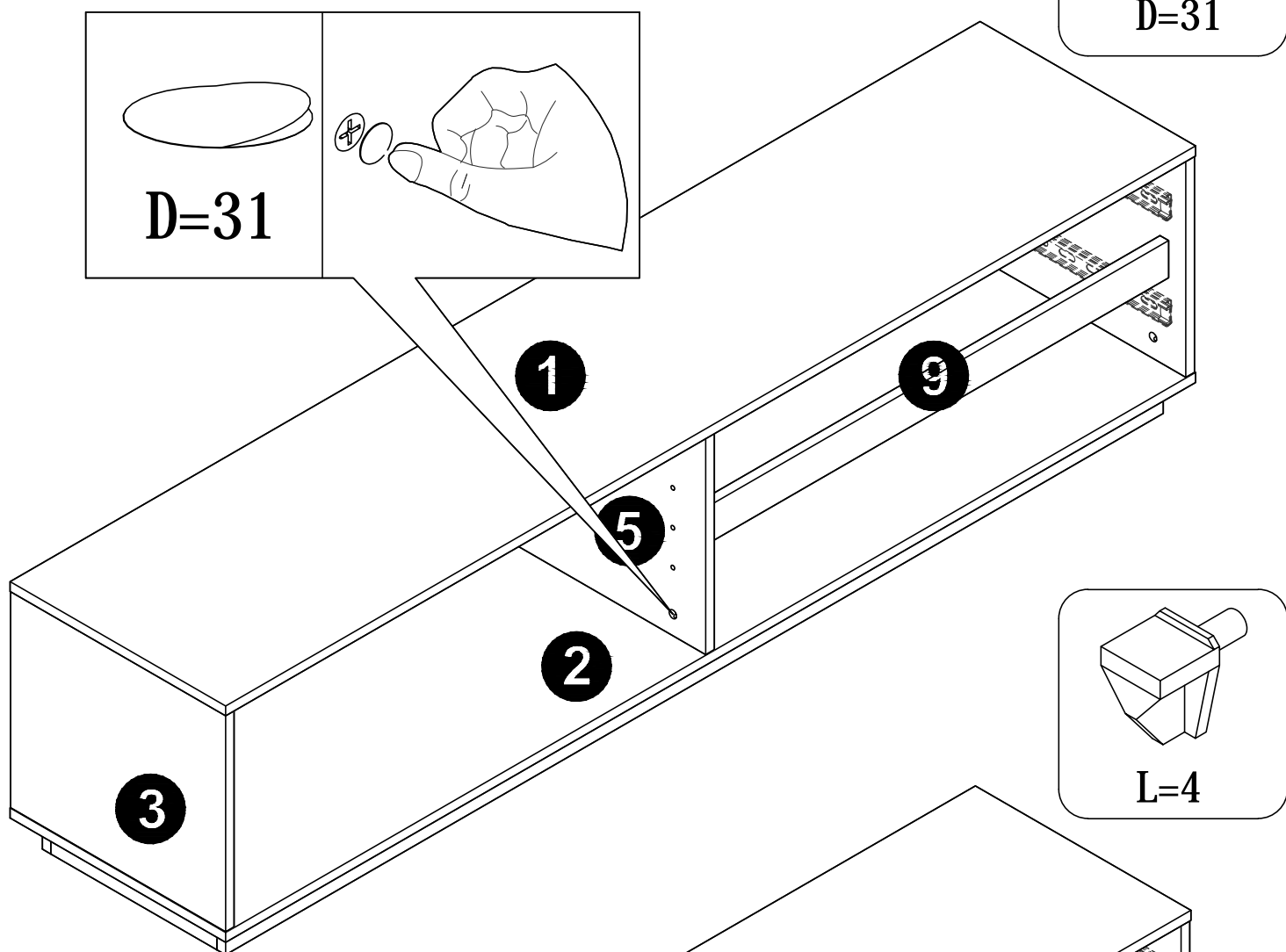

STEP 11

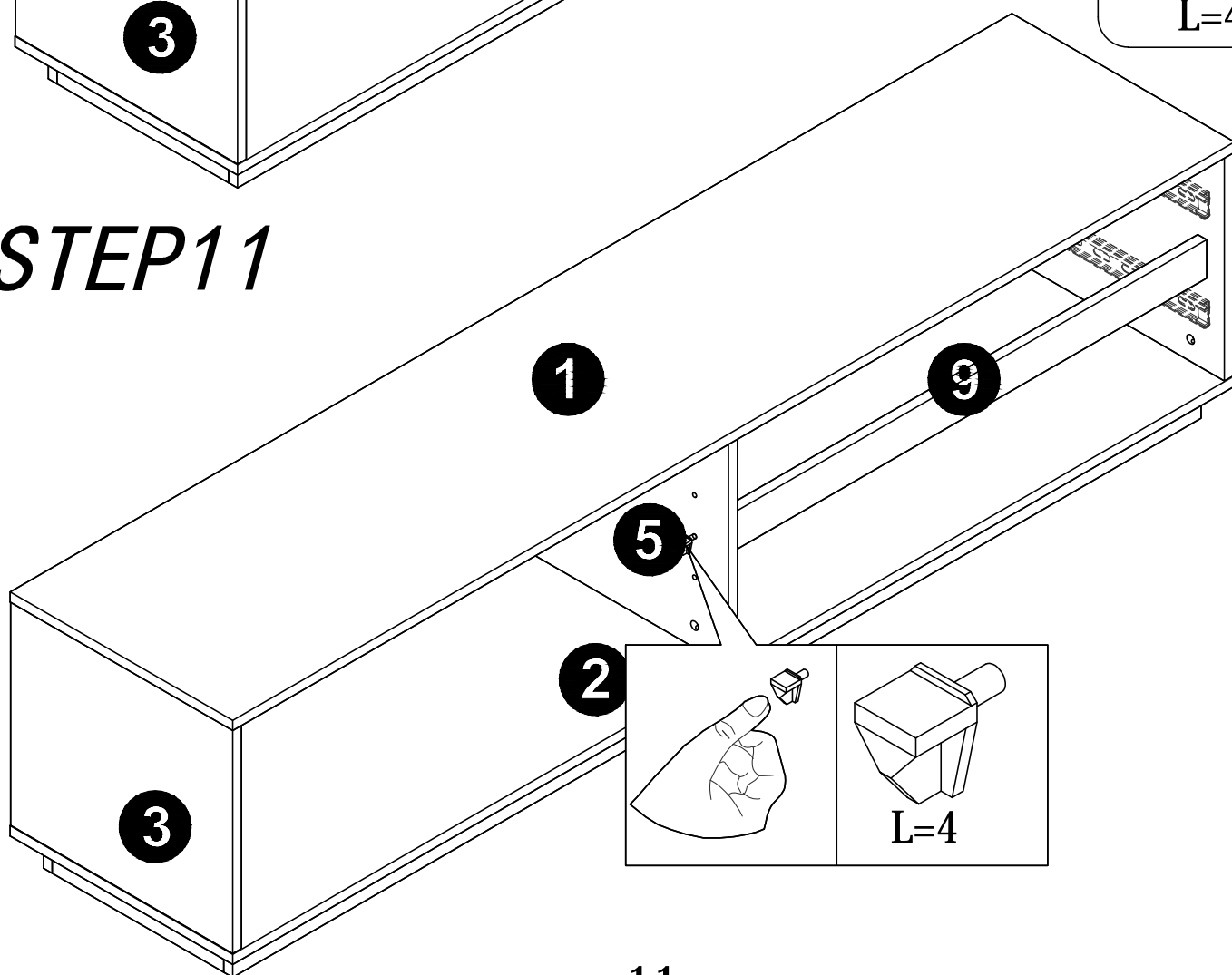

STEP 12

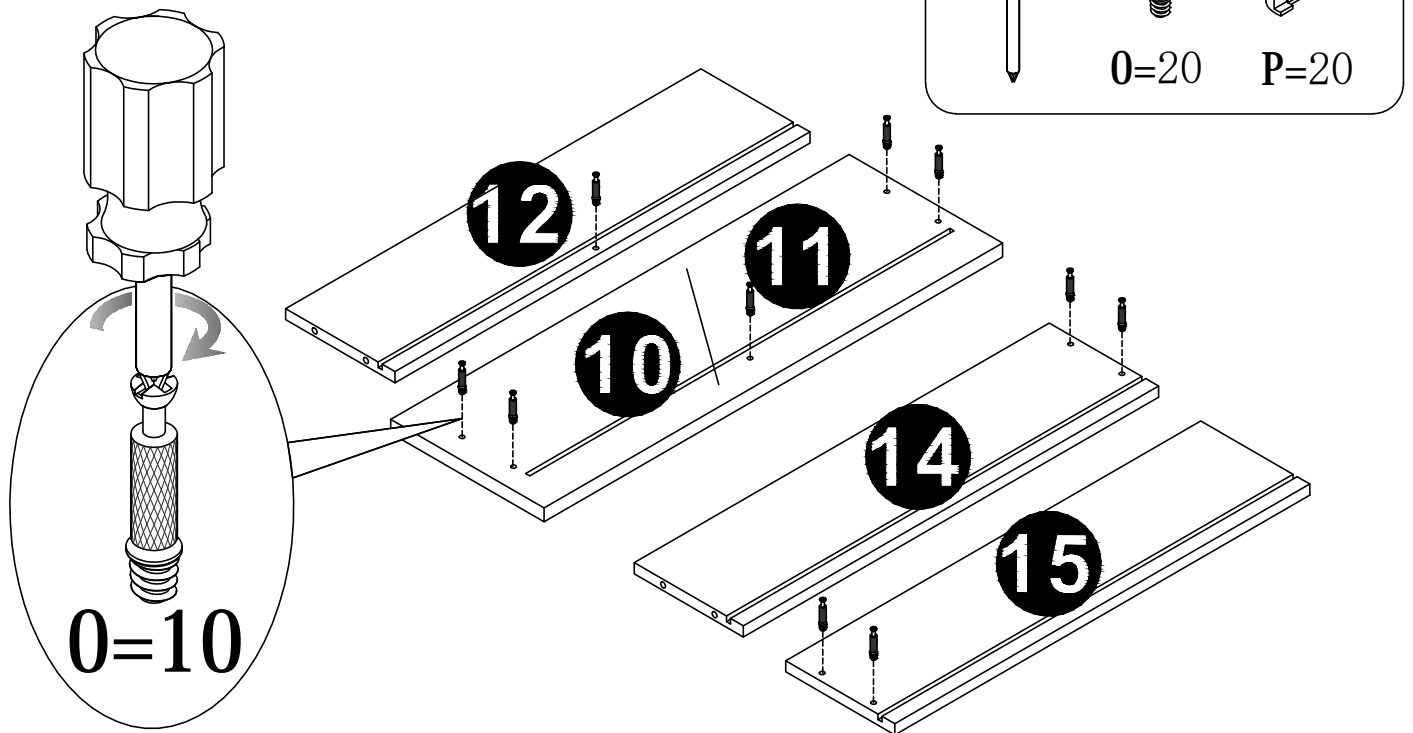

STEP 13

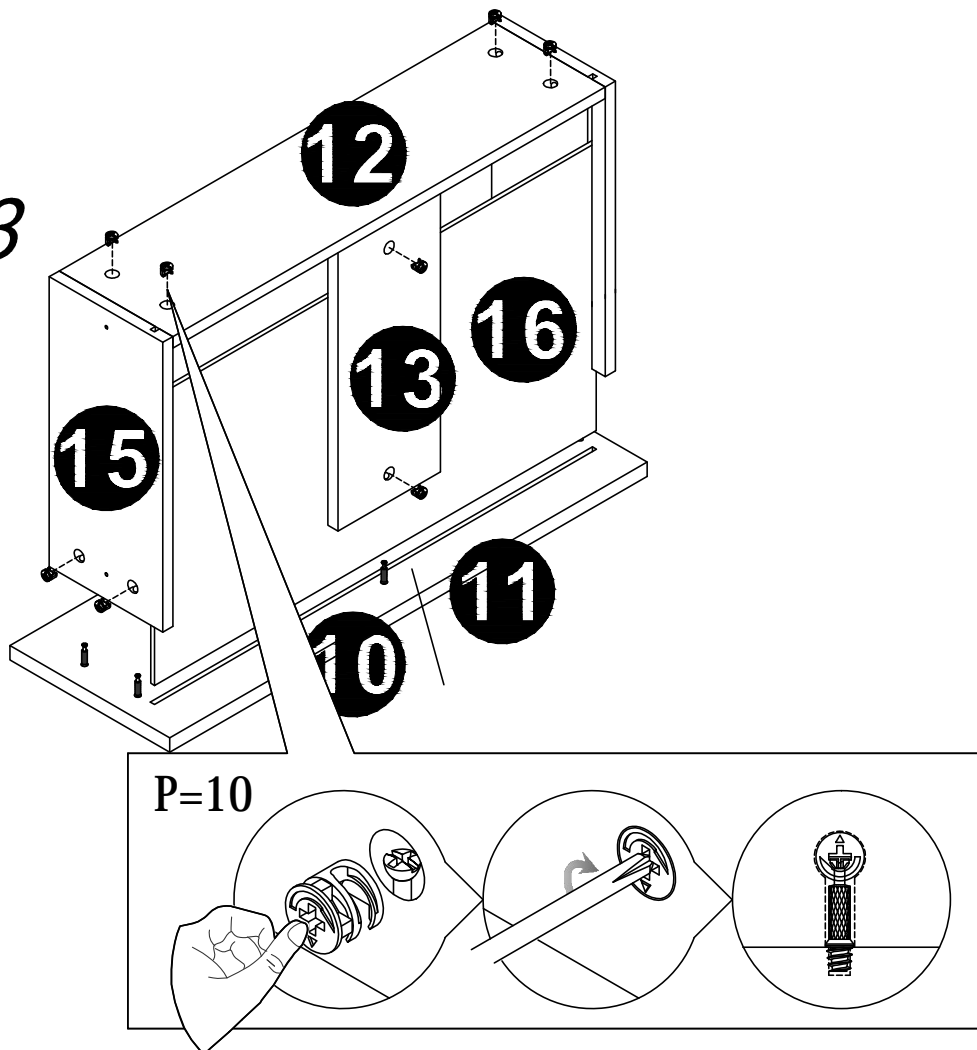

repeat for 2 drawers

STEP 14

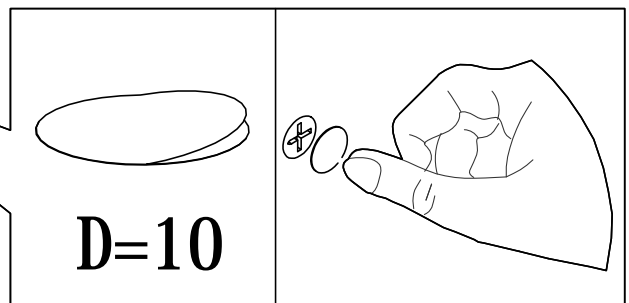
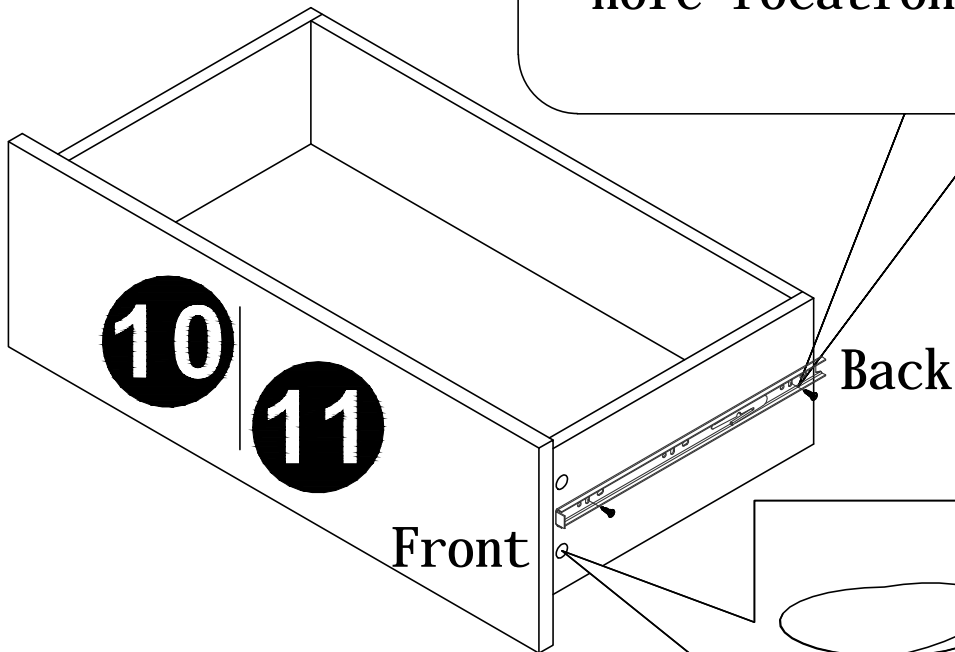
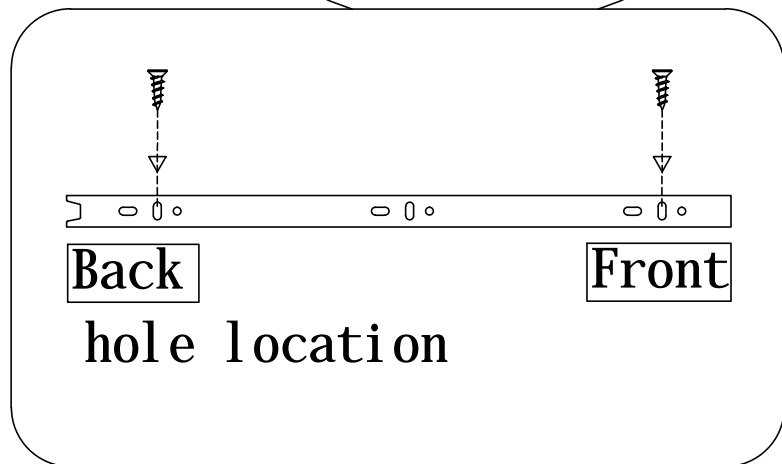
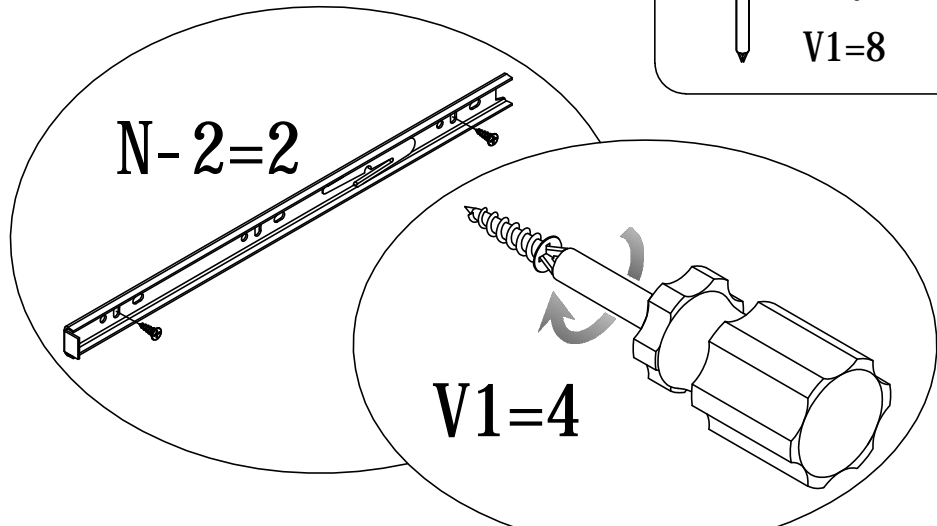
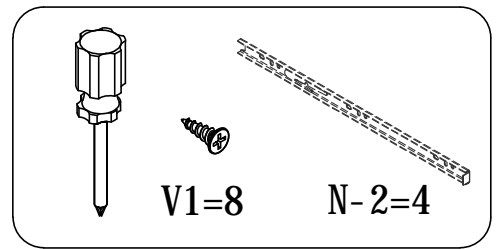

The drawers will allign evenly when you ensure the screw is in the same place

repeat for 2drawers

STEP 15

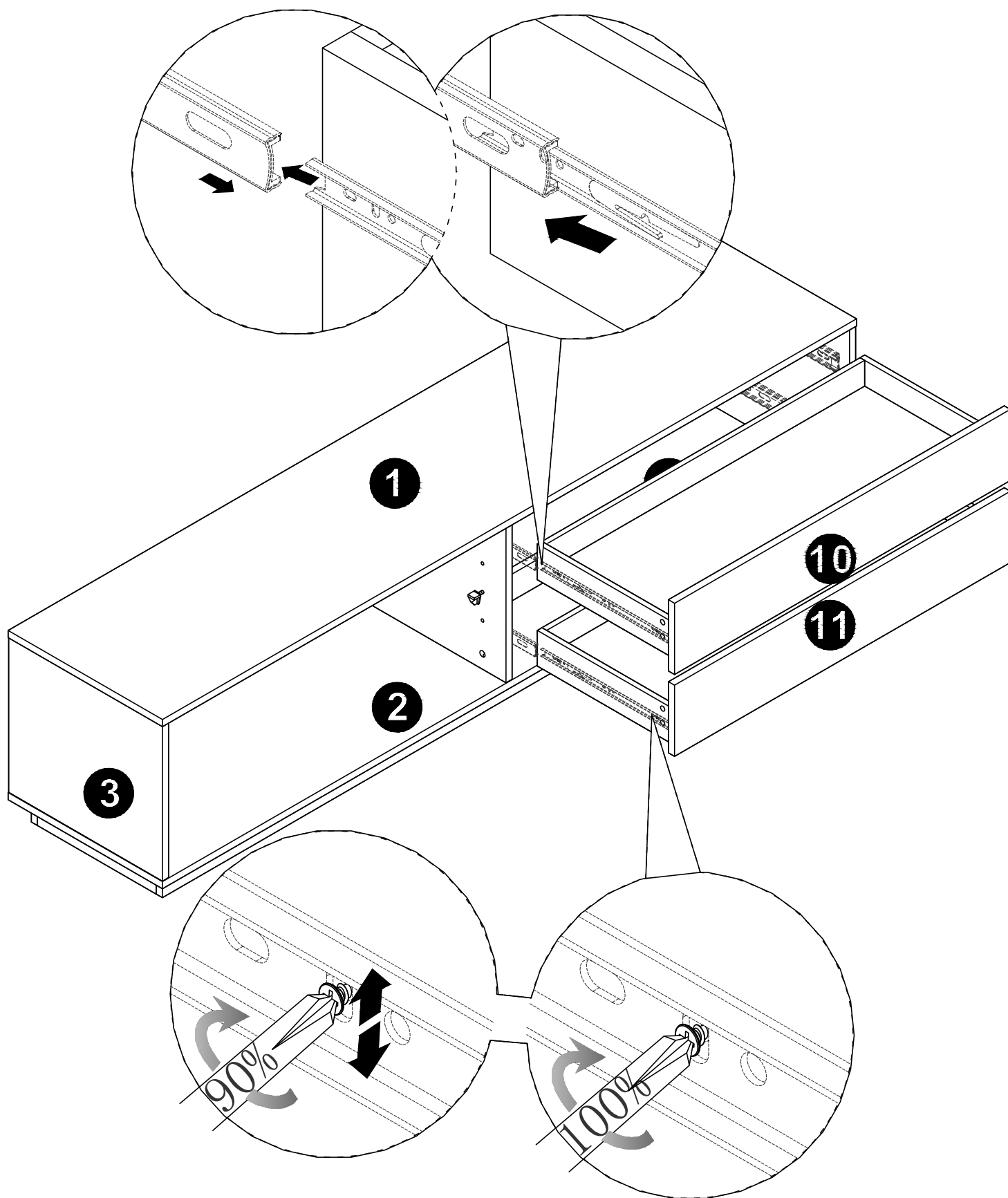

*If drawers are stiff or uneven, adjust the position of the screws on the drawer runners.
Try to keep all screws in the same position.*

STEP 16

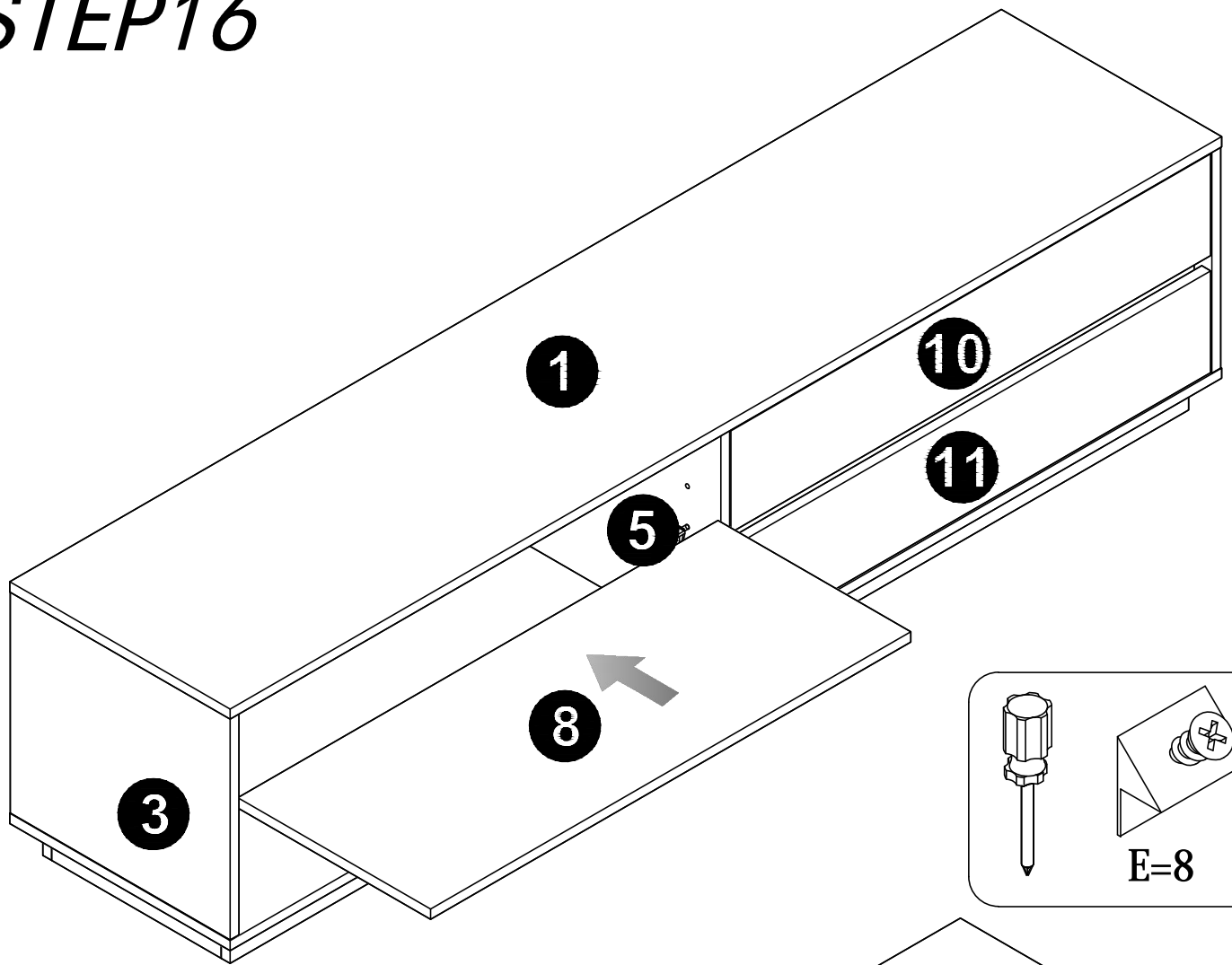

STEP 17

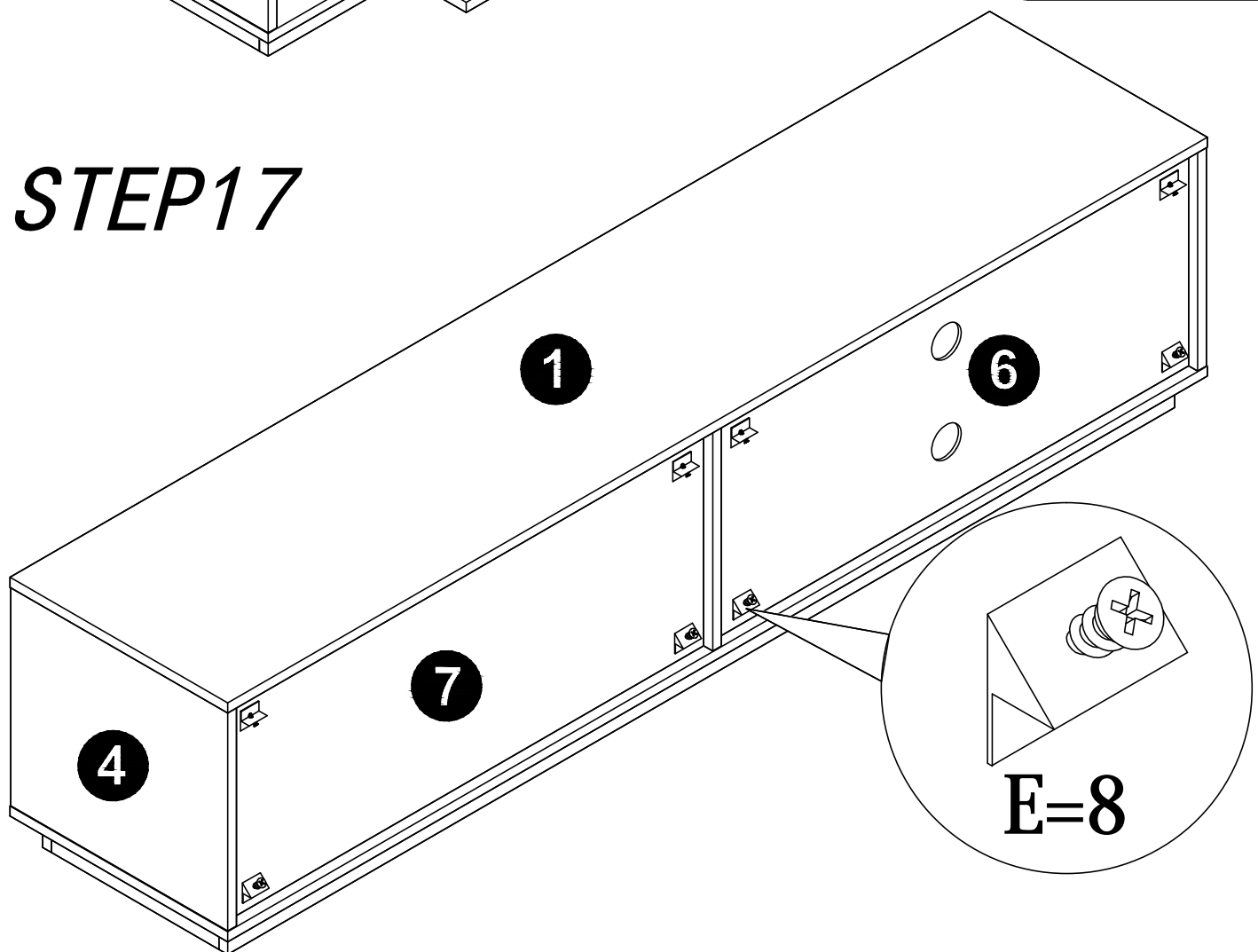

STEP18

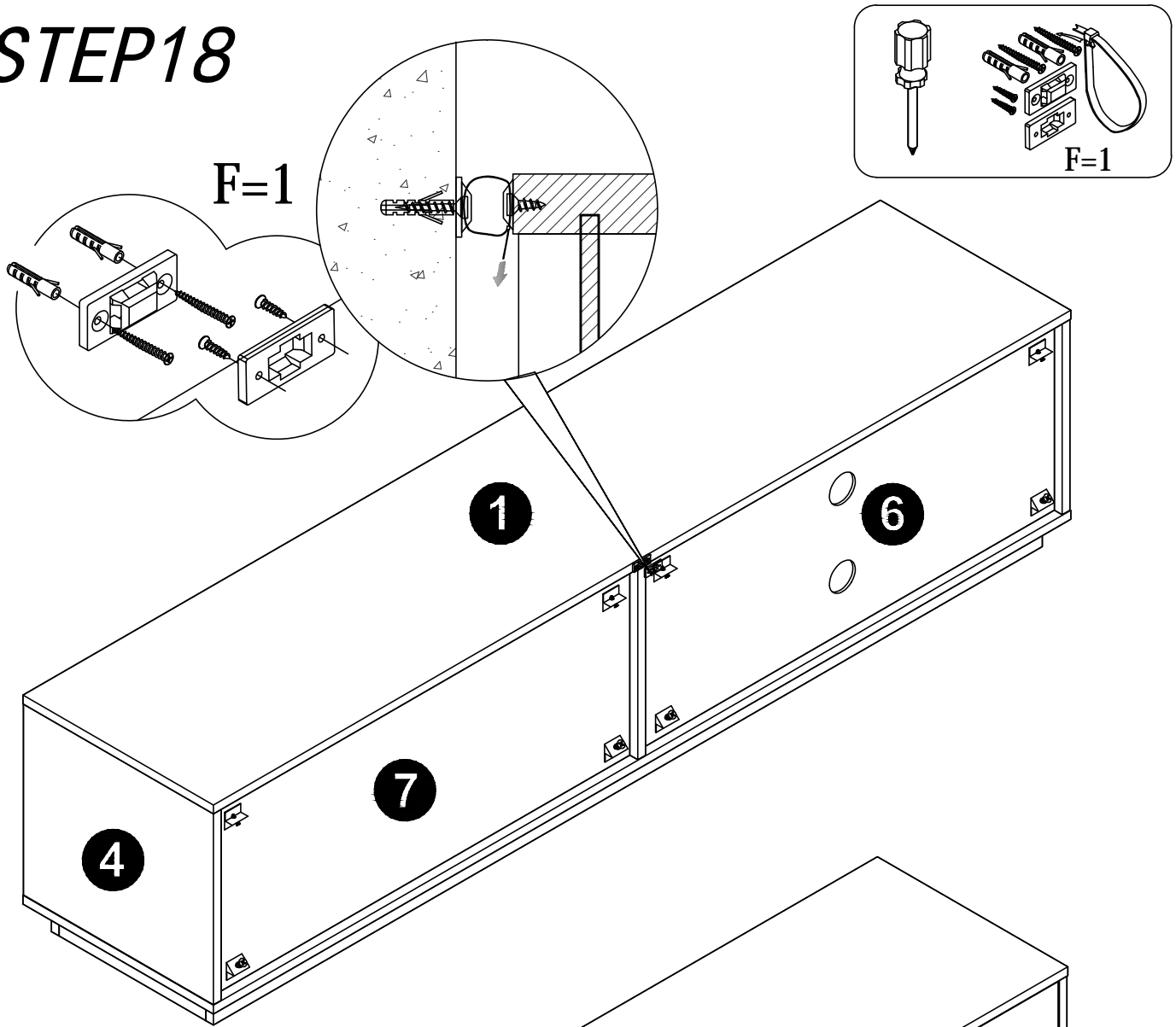

STEP19

