

# Assembly Instruction

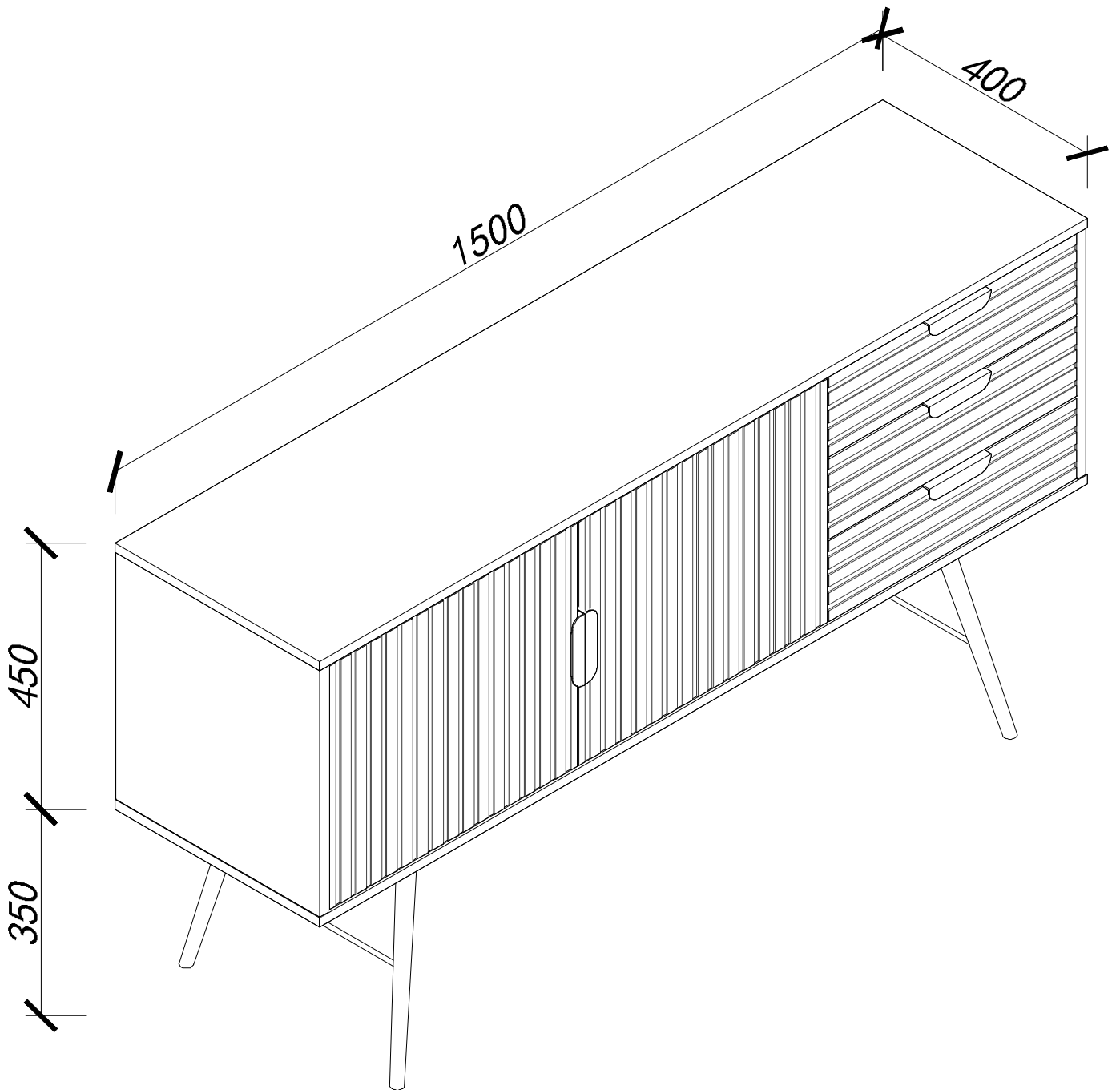

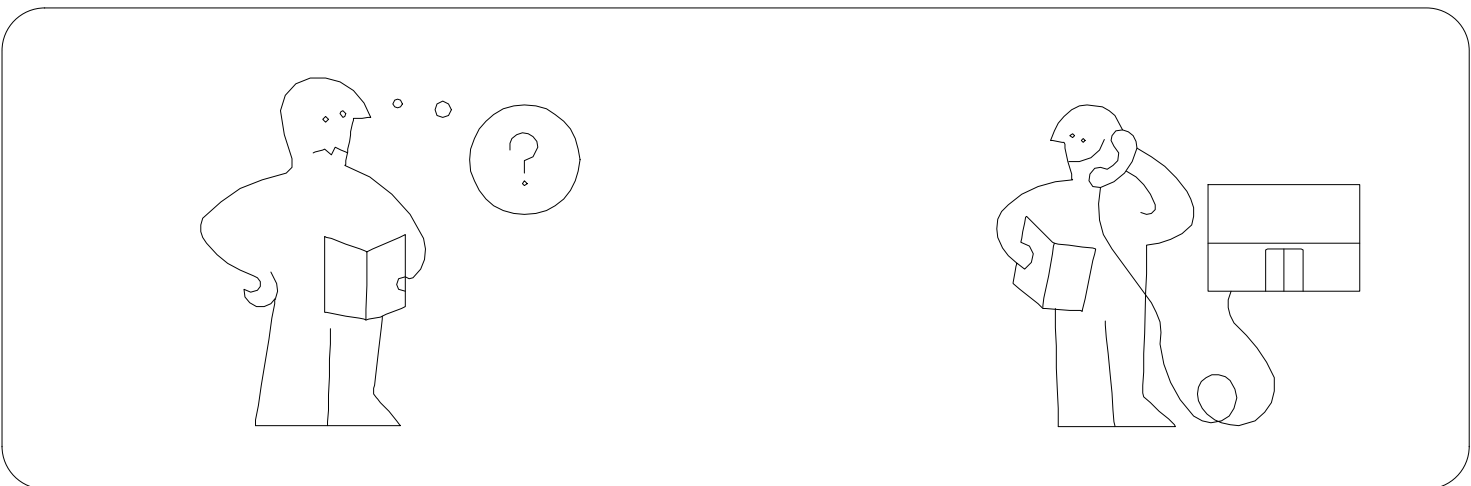
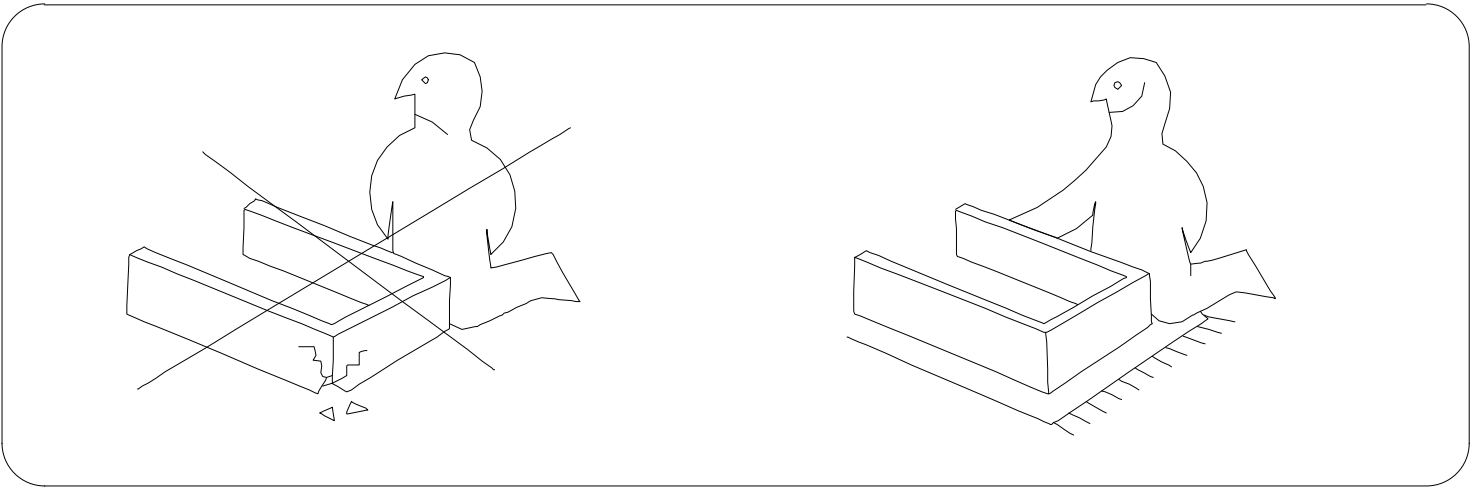
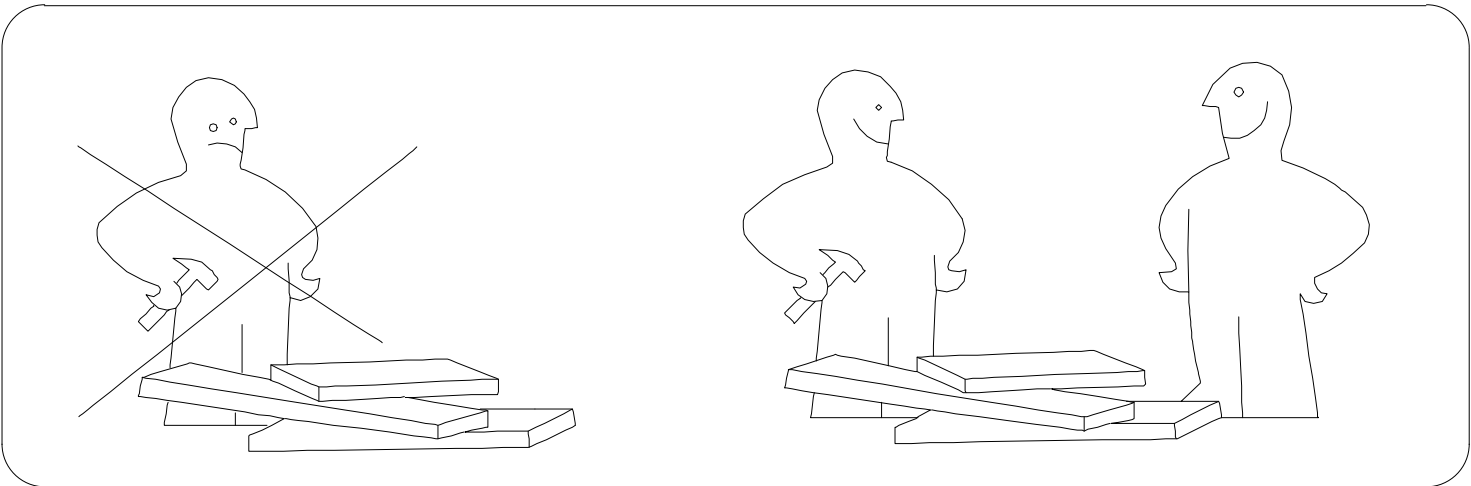
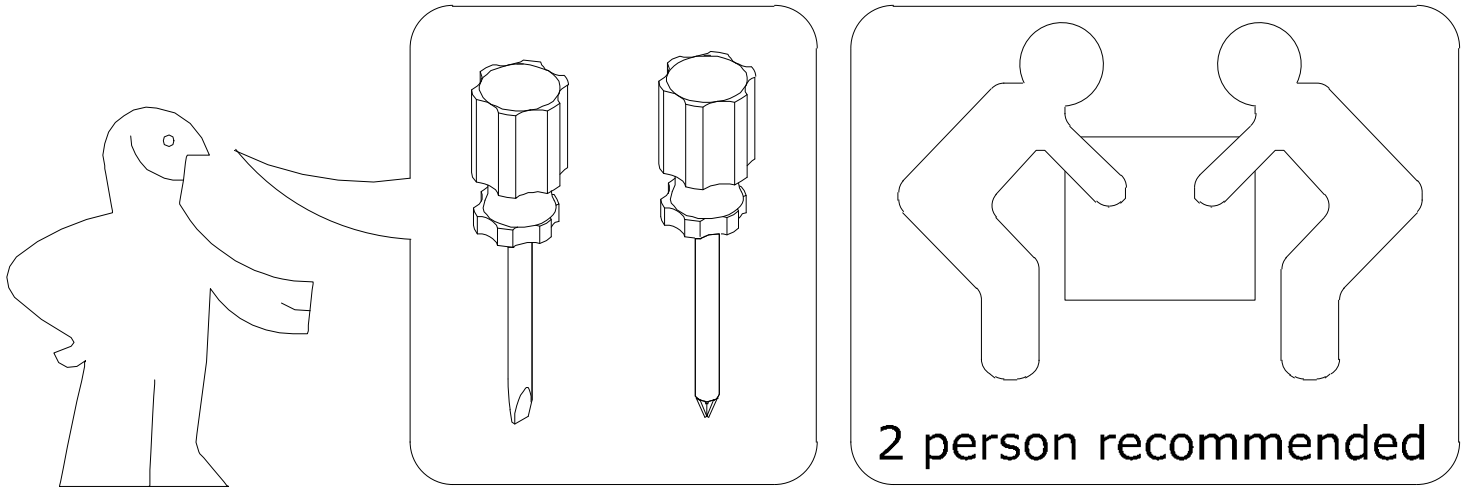

Panel No	Panel Sizes	Quantity
1	1500*400*16	1
2	1500*400*16	1
3	418*399*16	1
4	418*399*16	1
5	418*380*16	1
6	418*380*16	1
7	478*350*16	1
8	469*350*16	1

Panel No	Panel Sizes	Quantity
9	491*428*5	2
10	482*428*5	1
11A/B	412*485*18	2
12	484*136*18	3
13	431*80*12	3
14	350*80*12	3
15	350*80*12	3
16	441*348*5	3

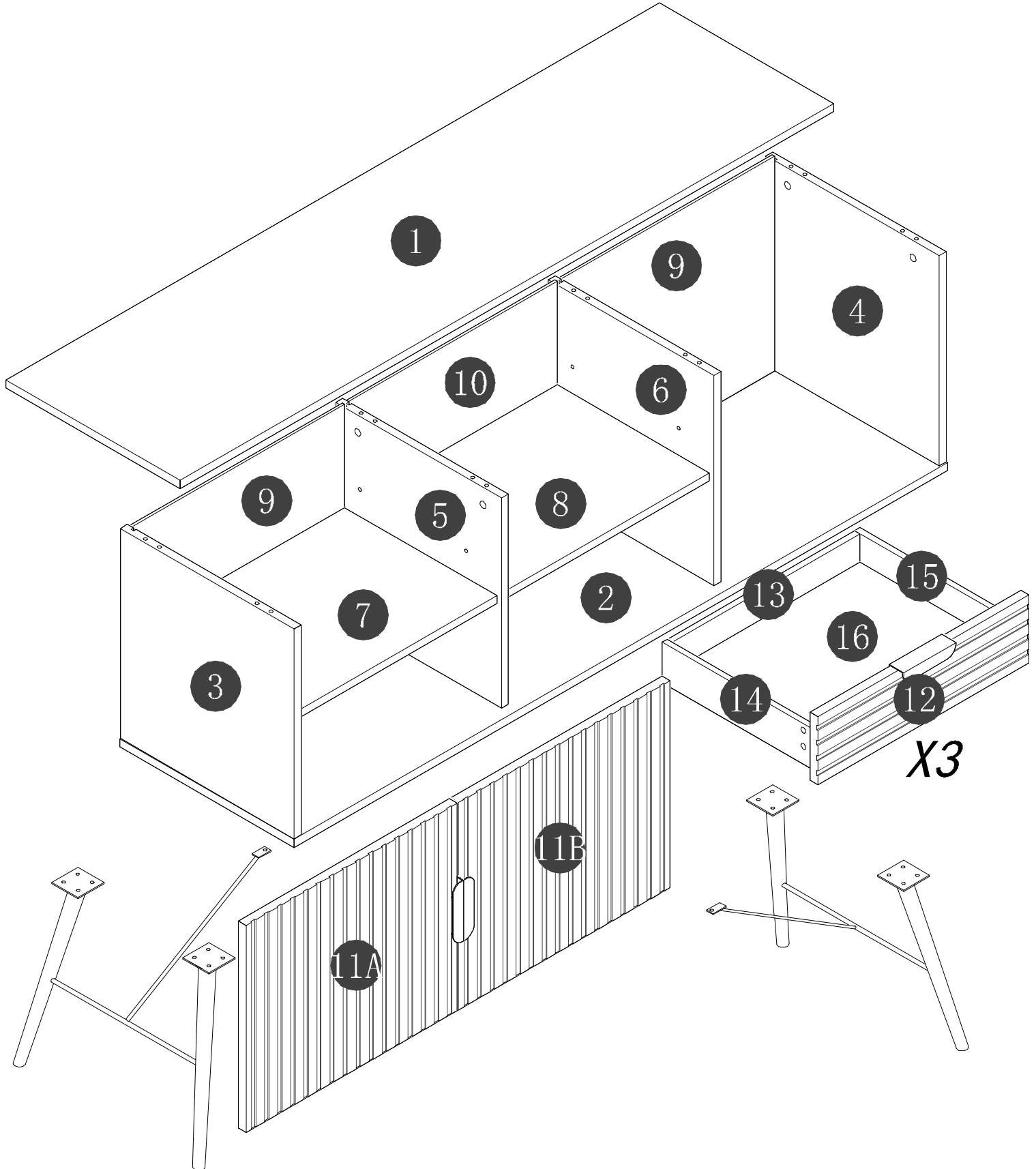

# Fittings

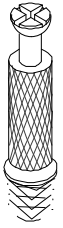

A=8

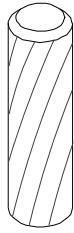

B=16

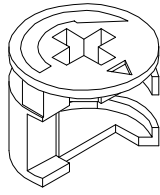

C=8



D=32

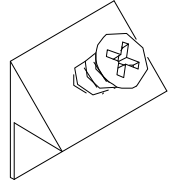

E=12

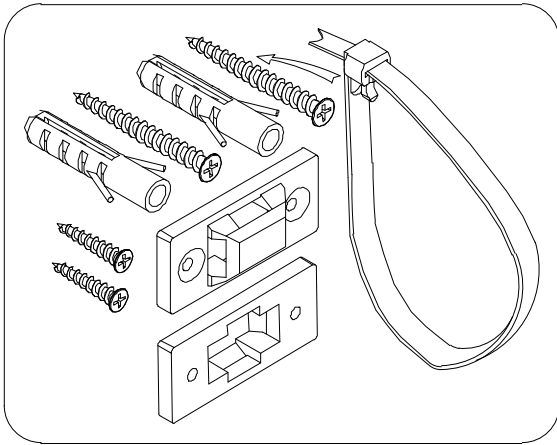

F=1



G1=18

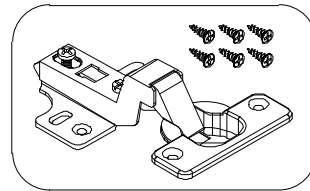

I3=2

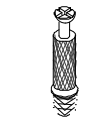

O=24



H=1

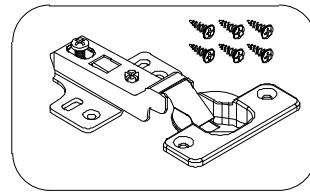

I2=2

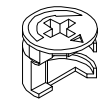

P=24

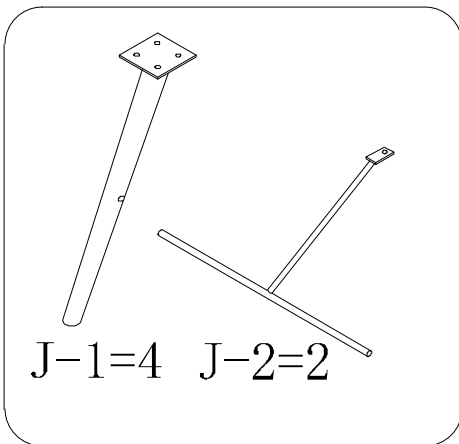

J-1=4 J-2=2

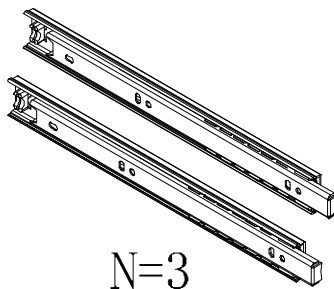

N=3



L=8

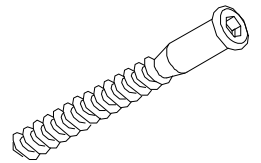

Q=8



Z1=18

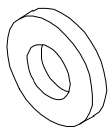

Z2=18



V1=24

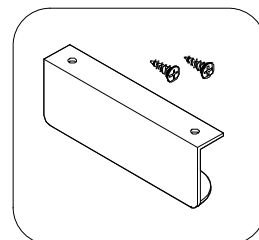

U=5

# STEP 1

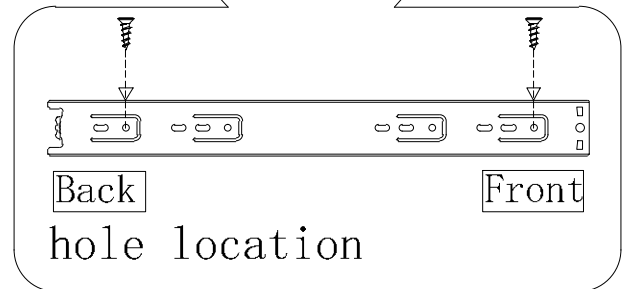
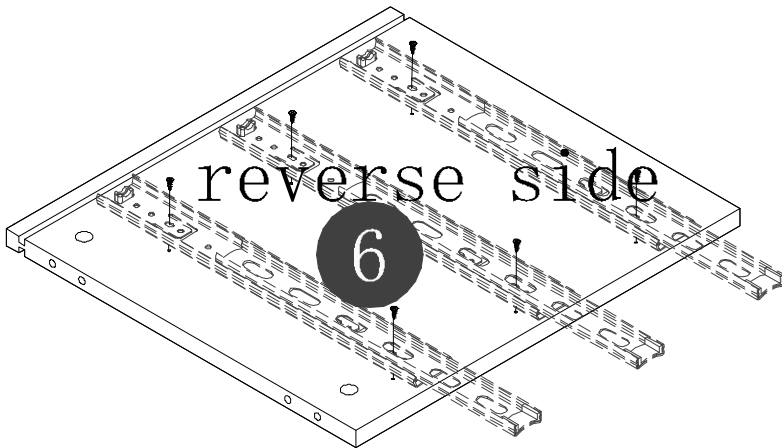
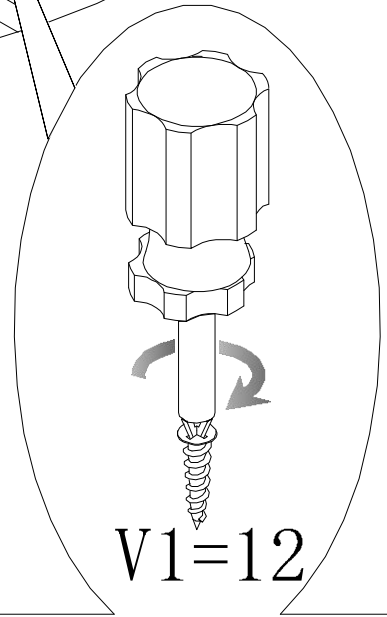
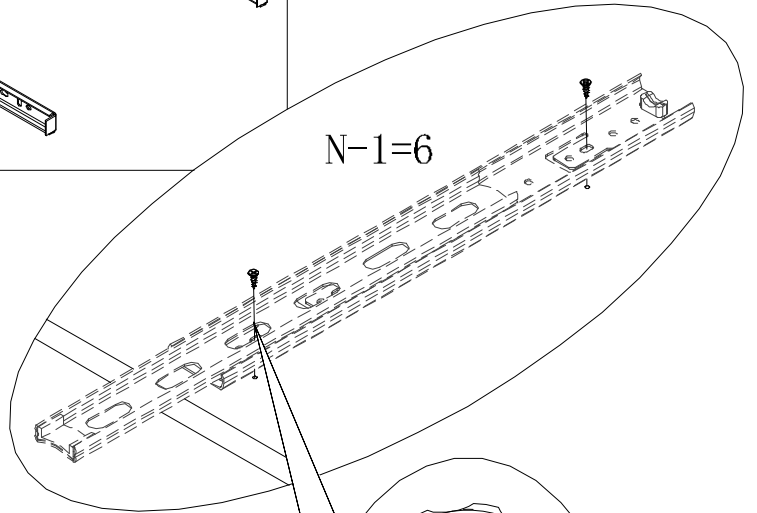
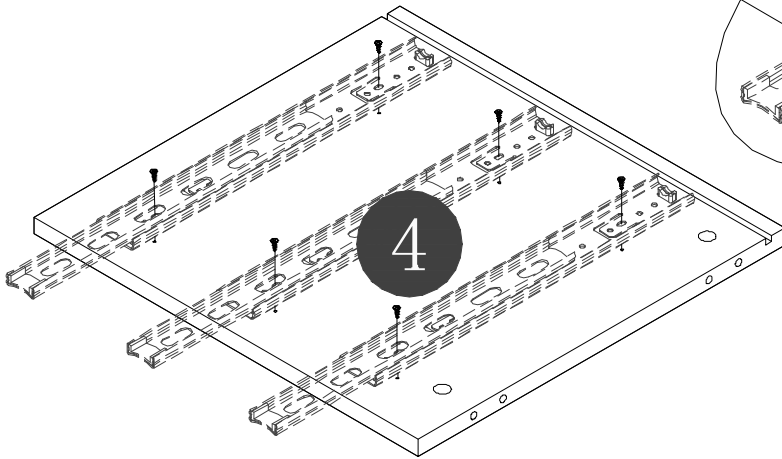
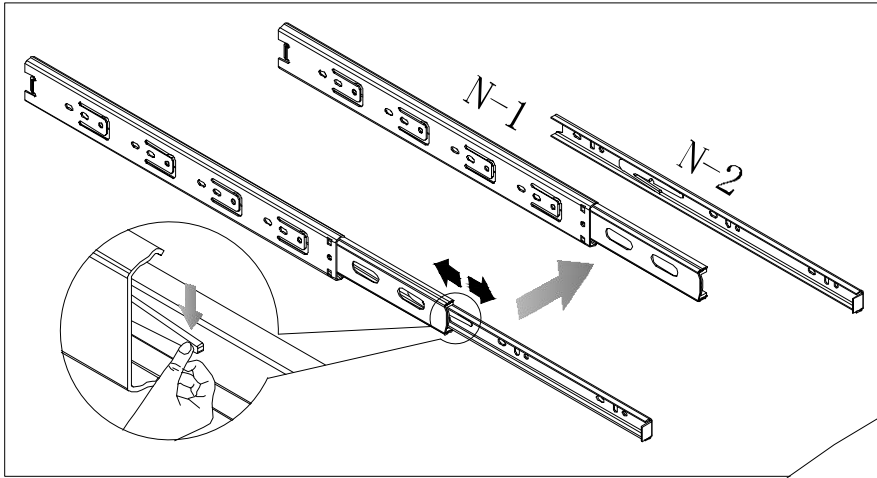

# STEP 2

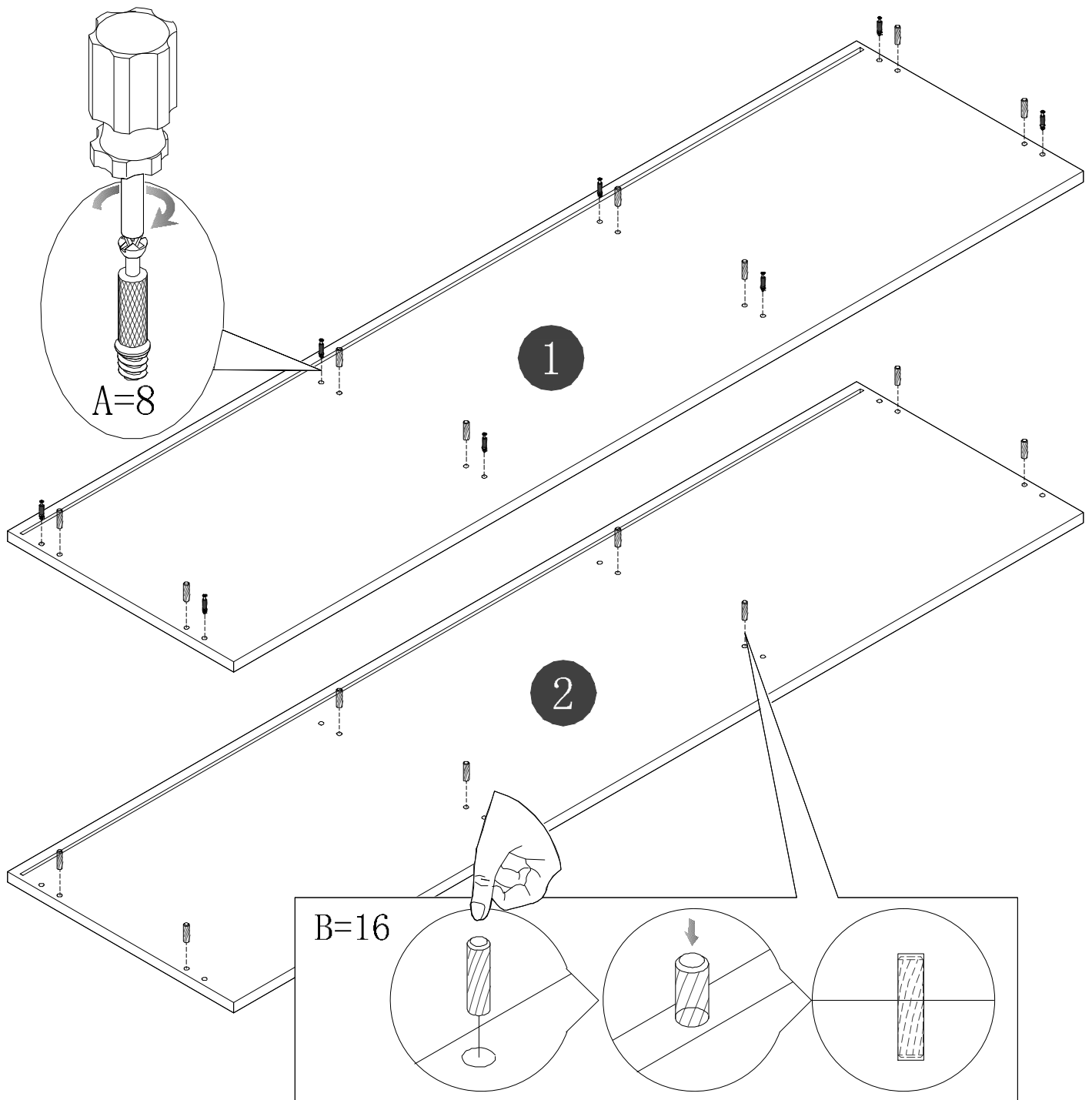

# STEP 3

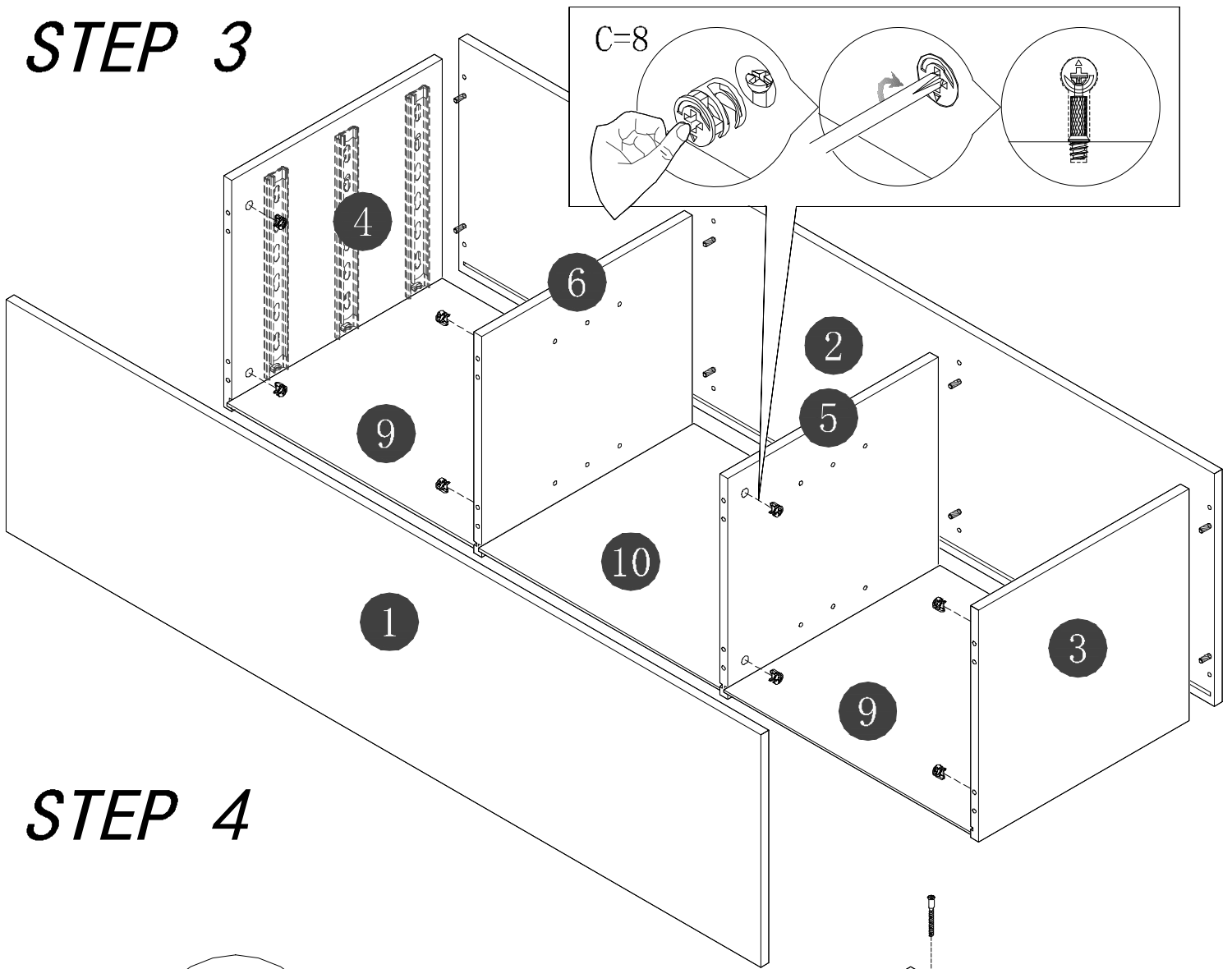

# STEP 4

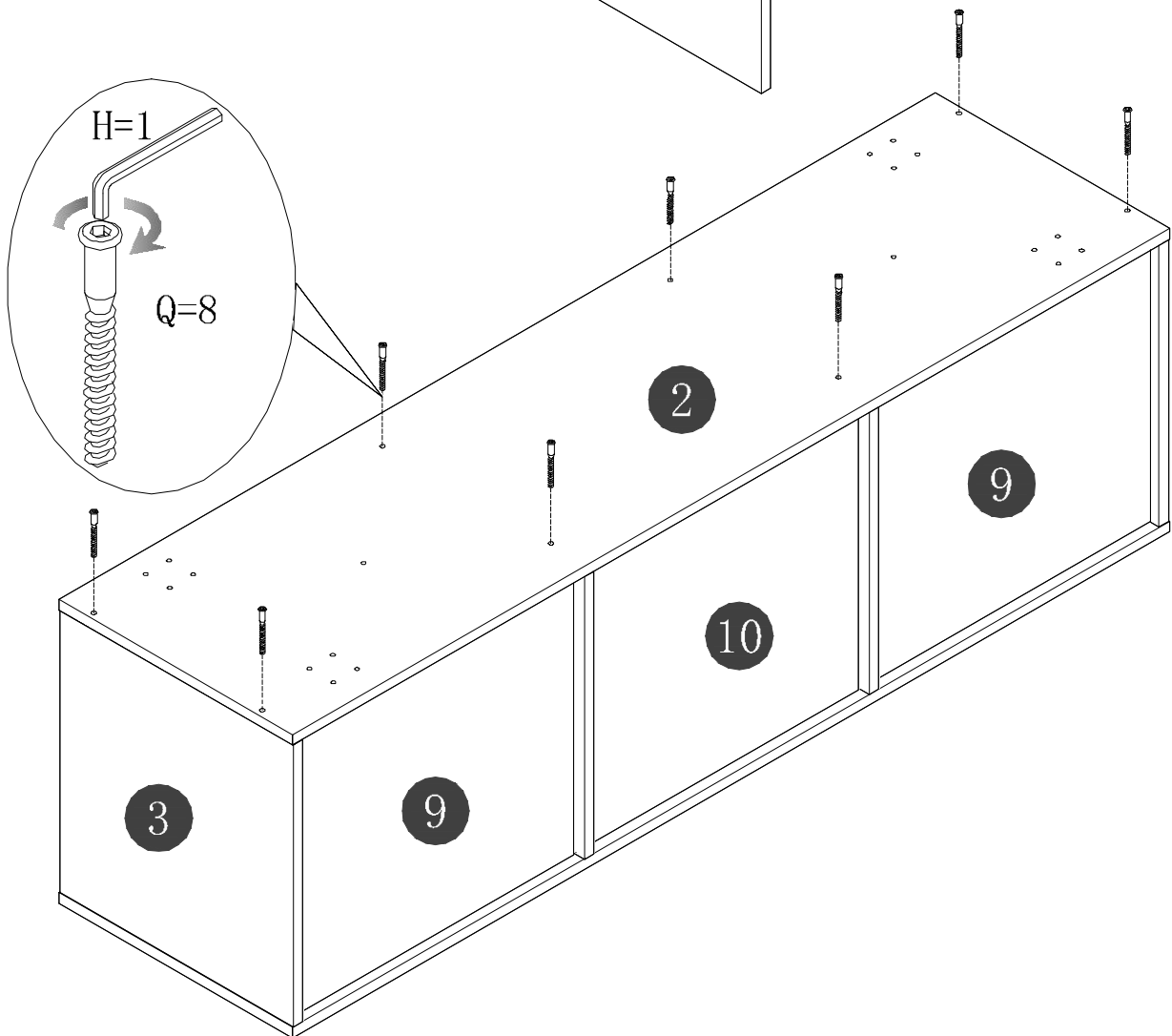

# STEP 5

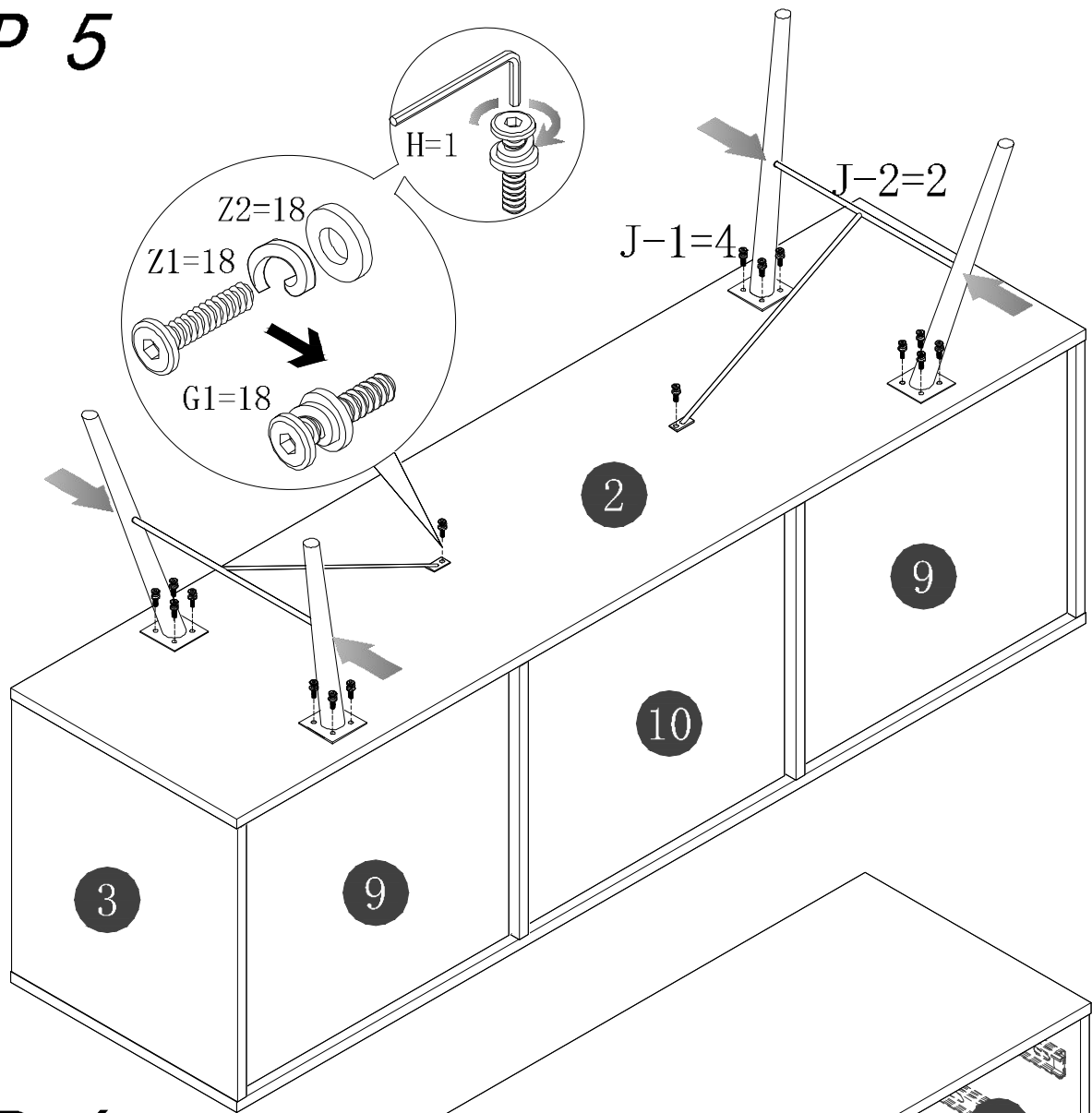

# STEP 6

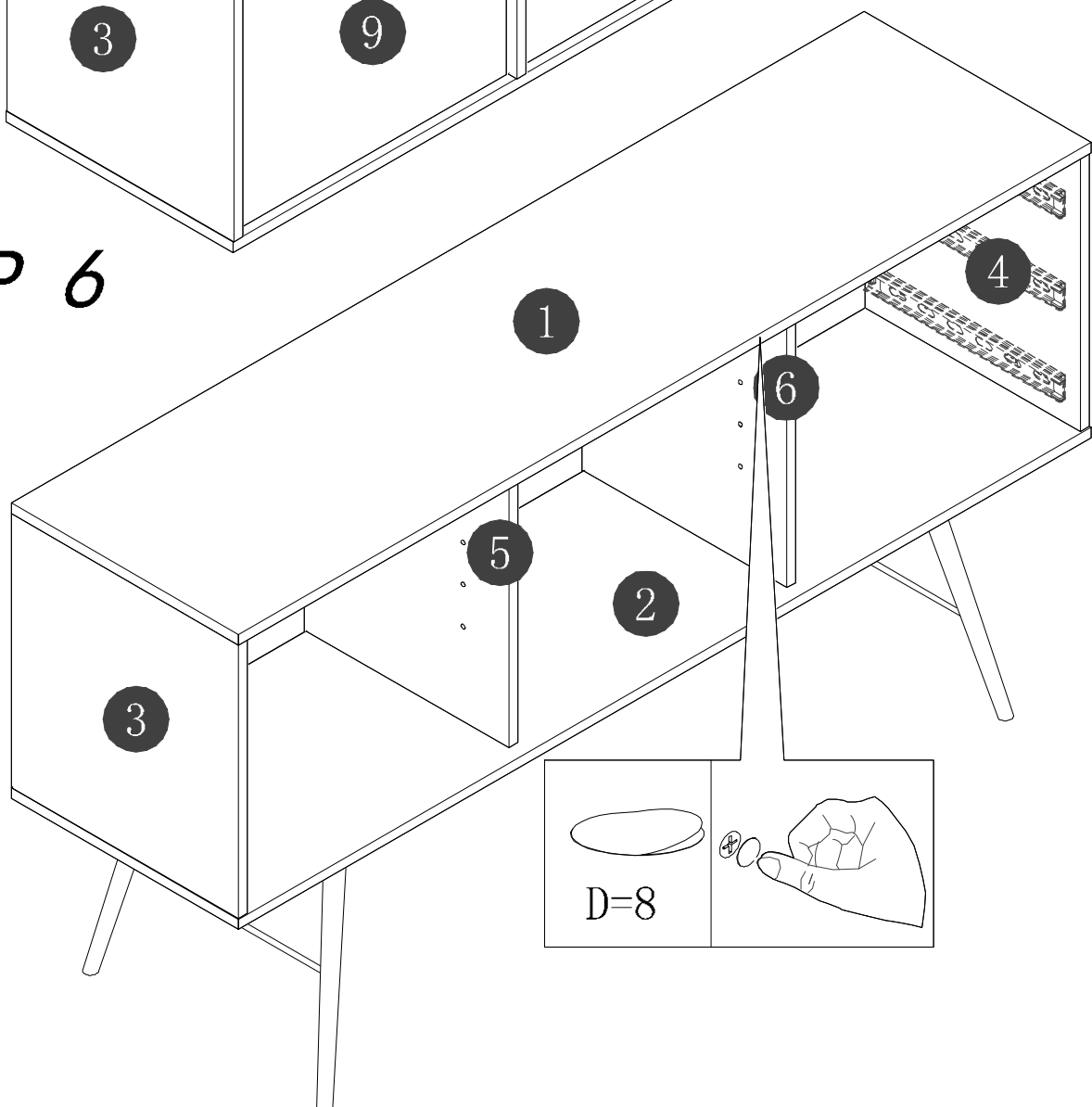



# STEP 7

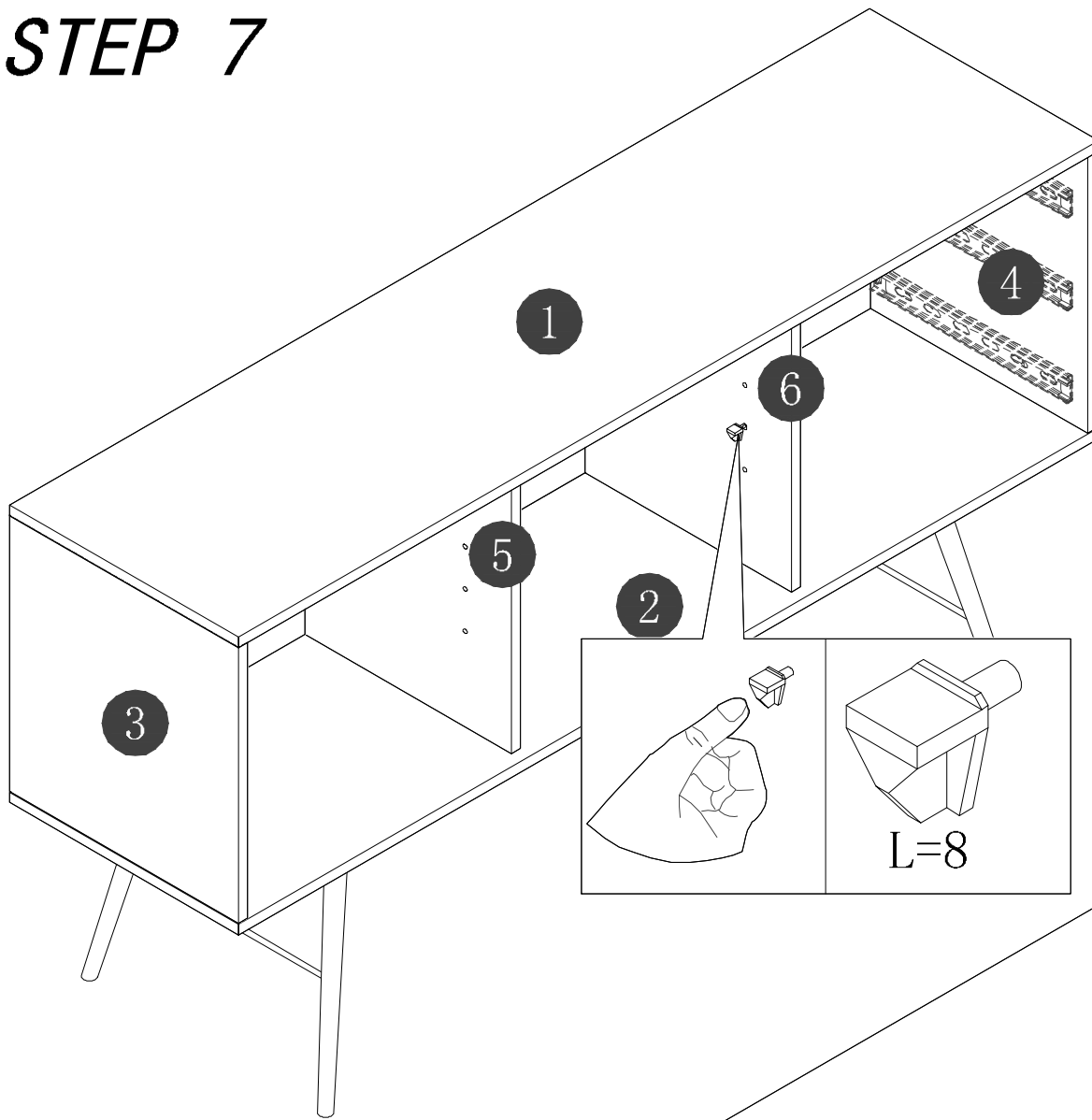

# STEP 8

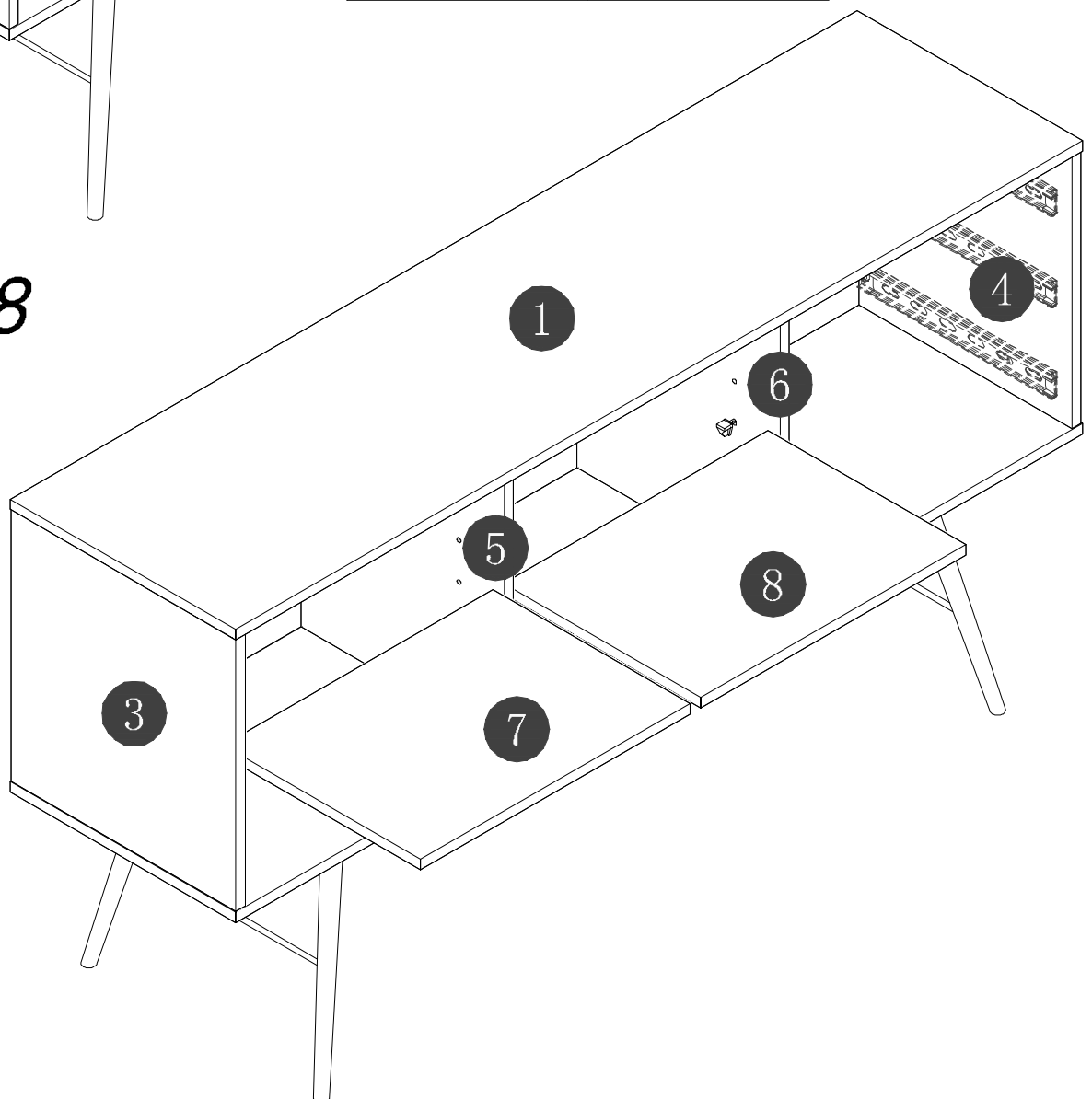

# STEP 9

9-1

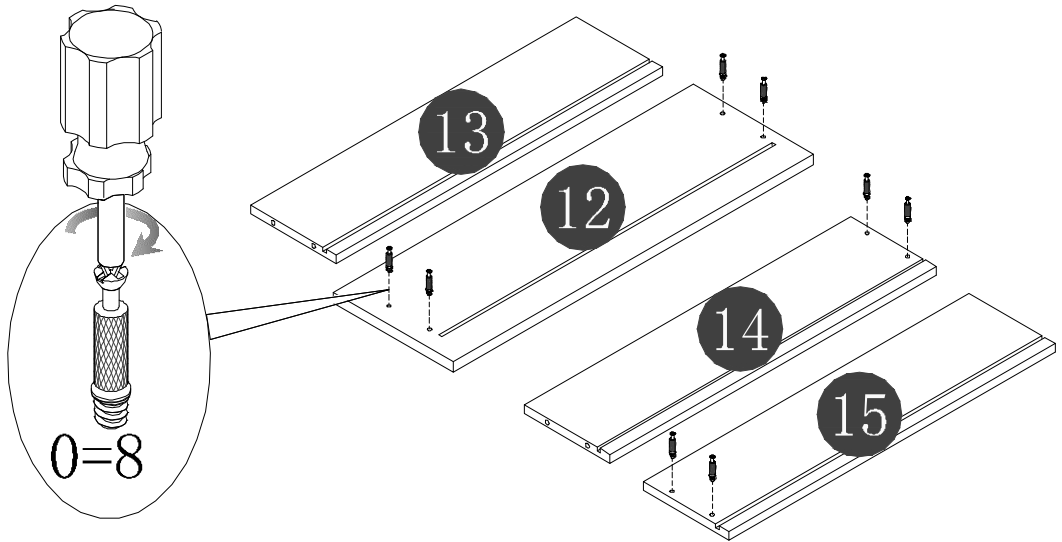

9-2

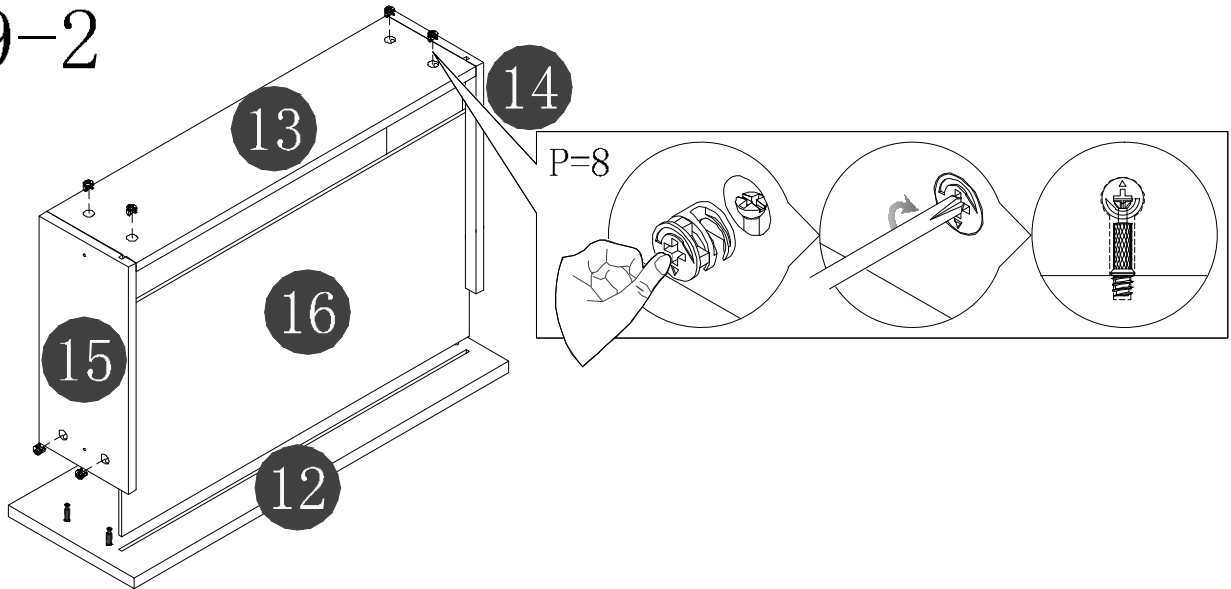

9-3

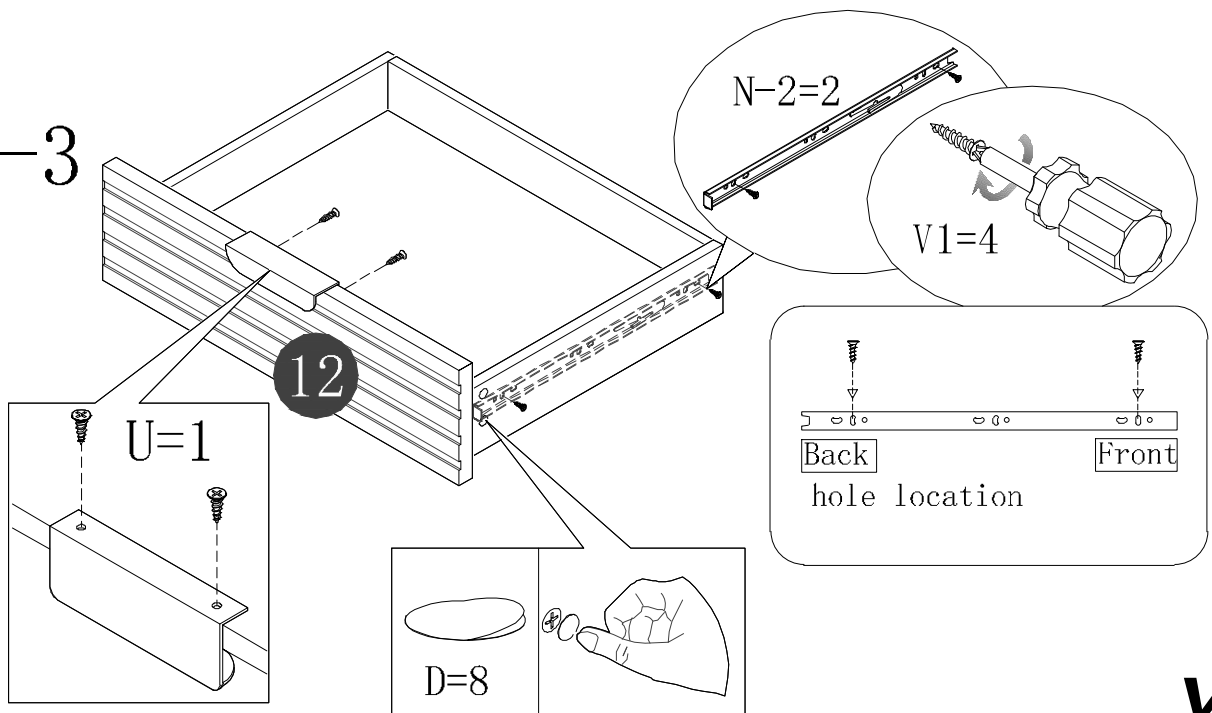

X3

# STEP 10

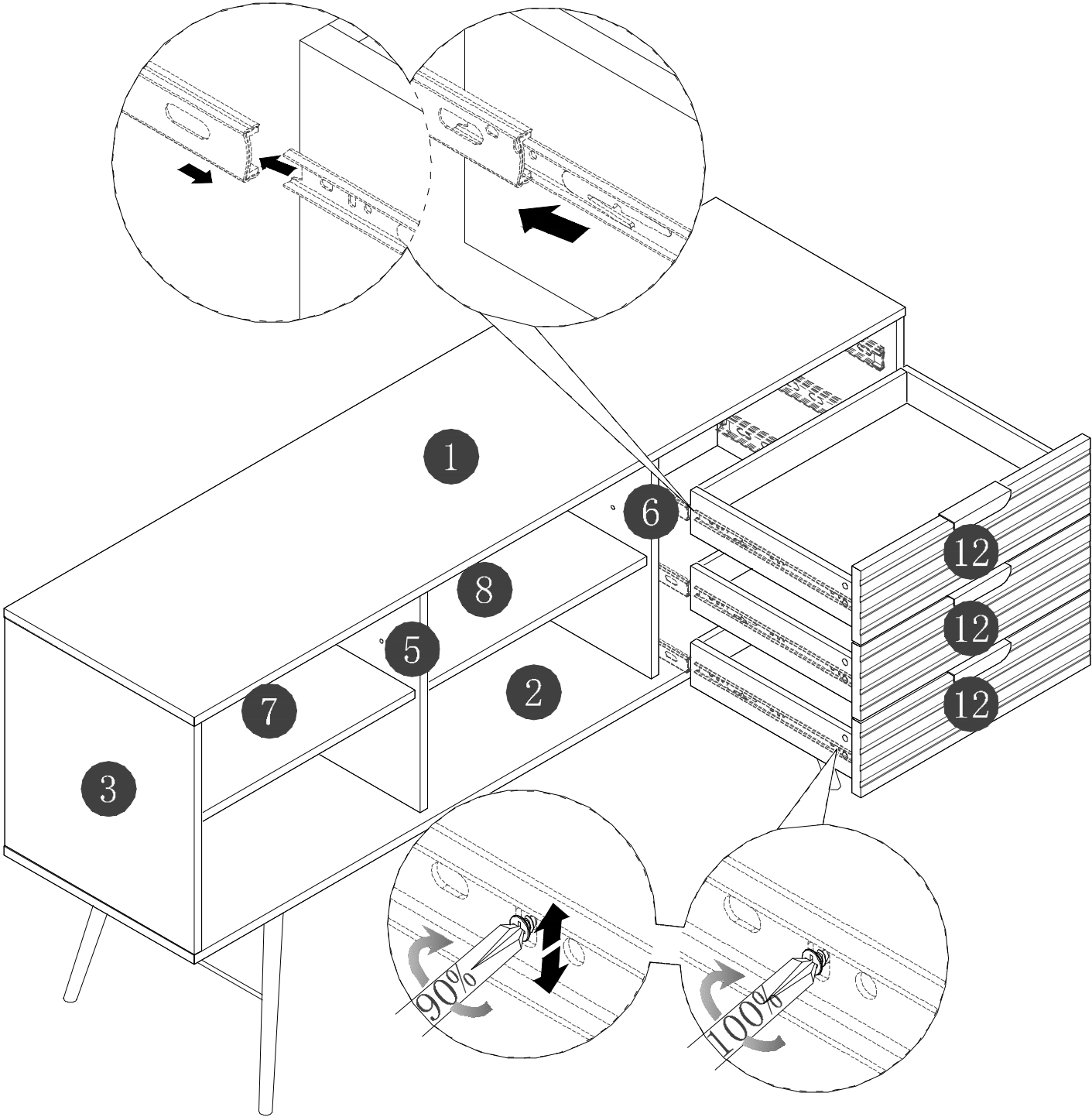

# STEP 11

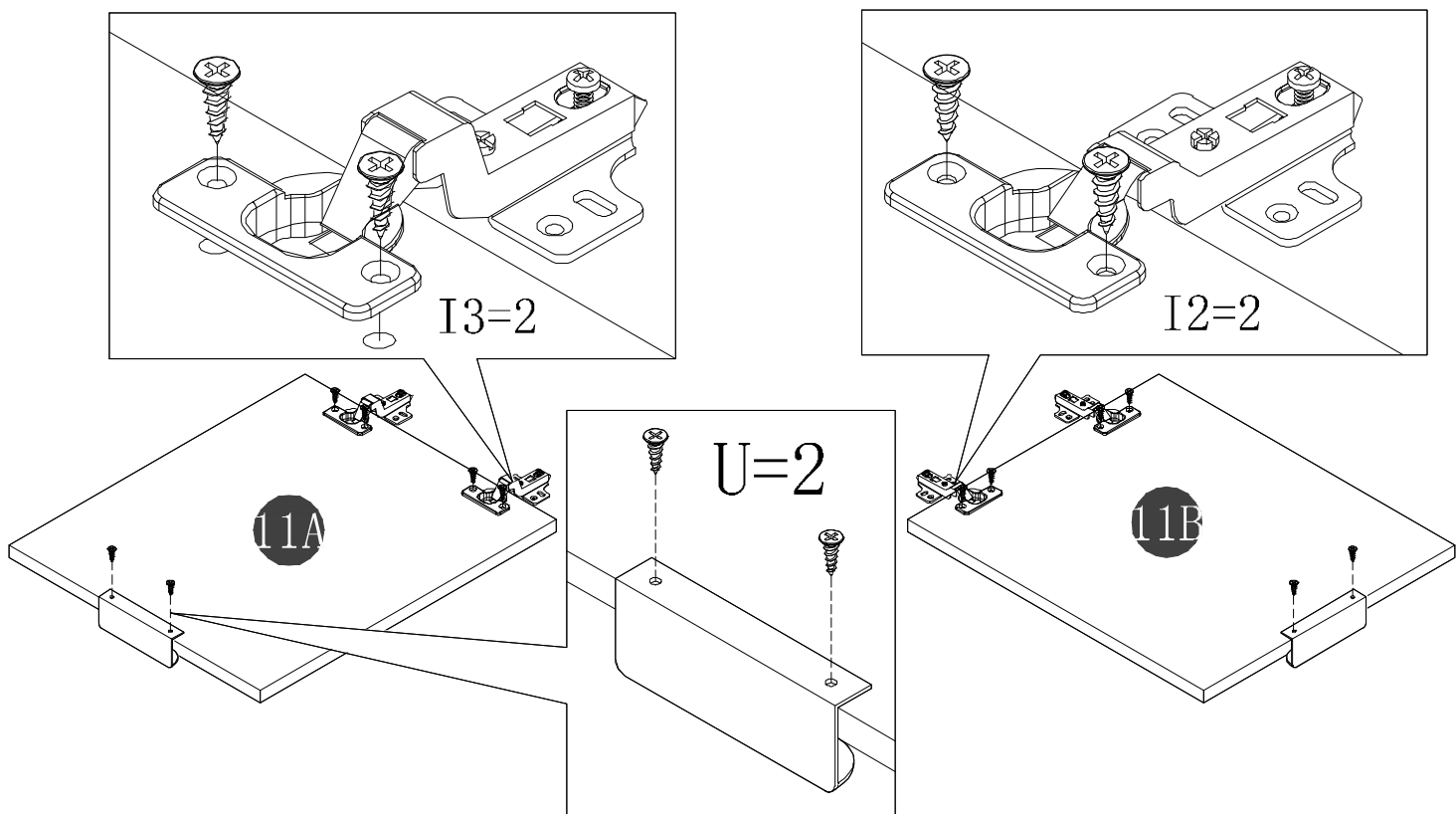

# STEP 12

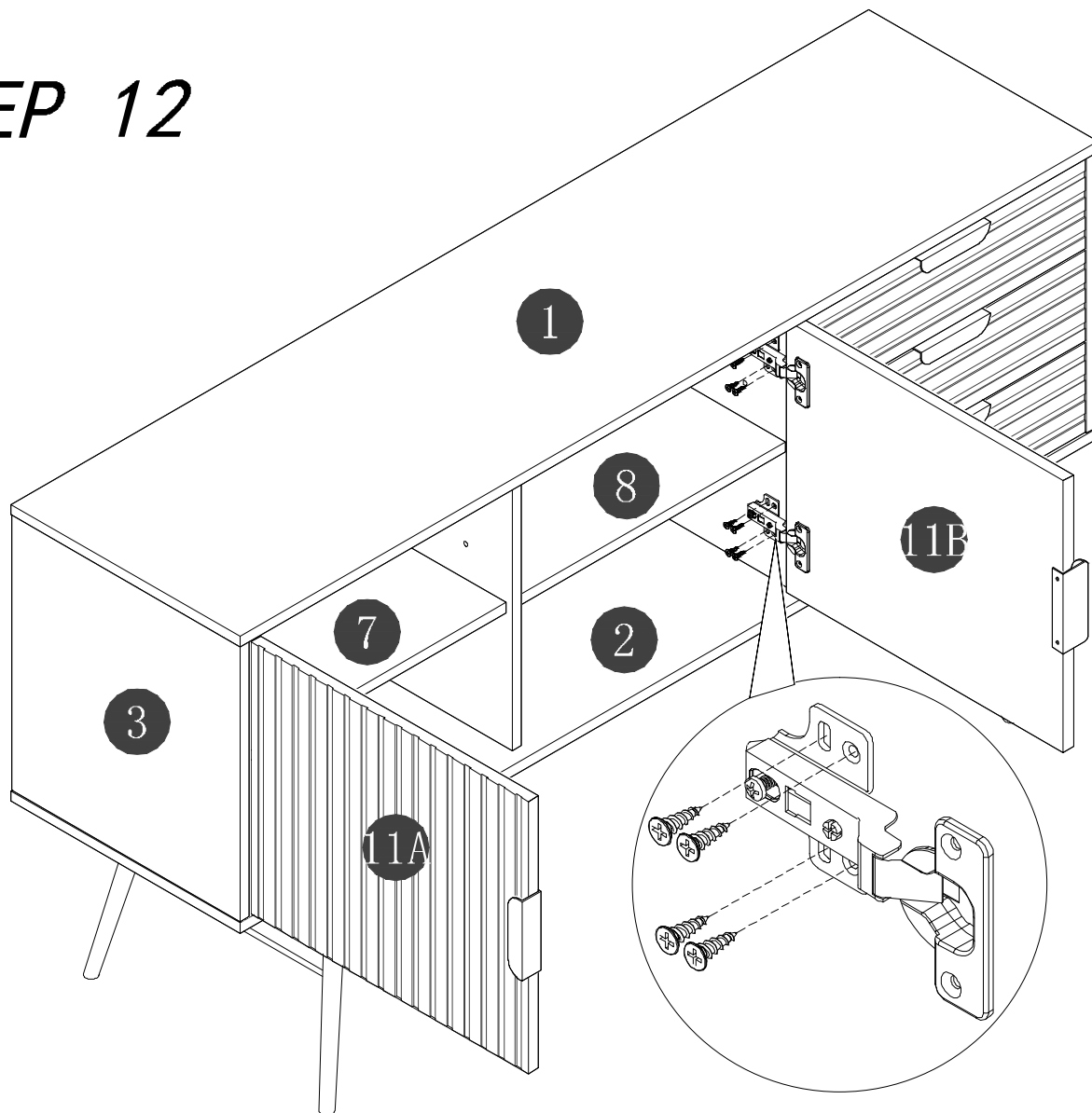

# STEP 13

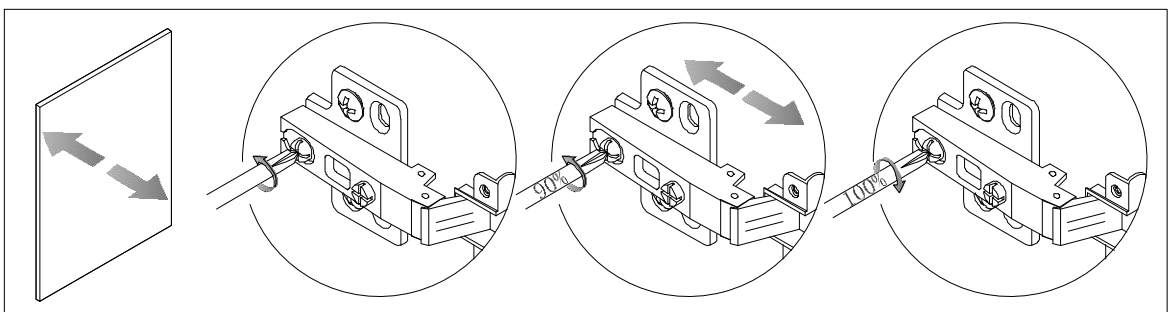
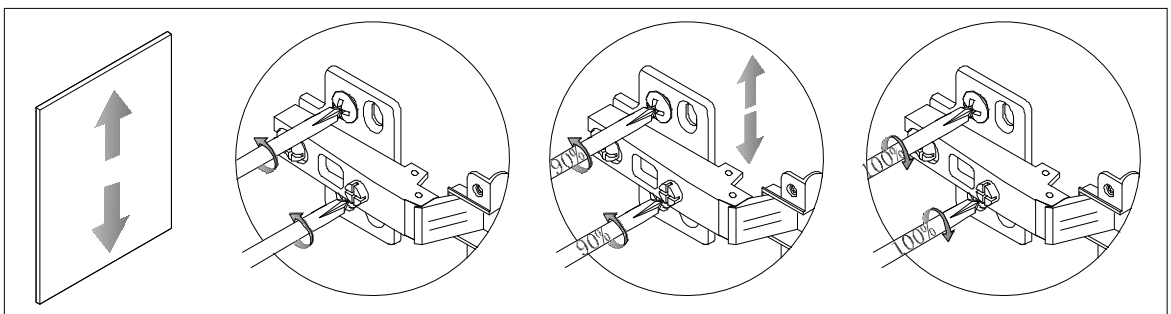
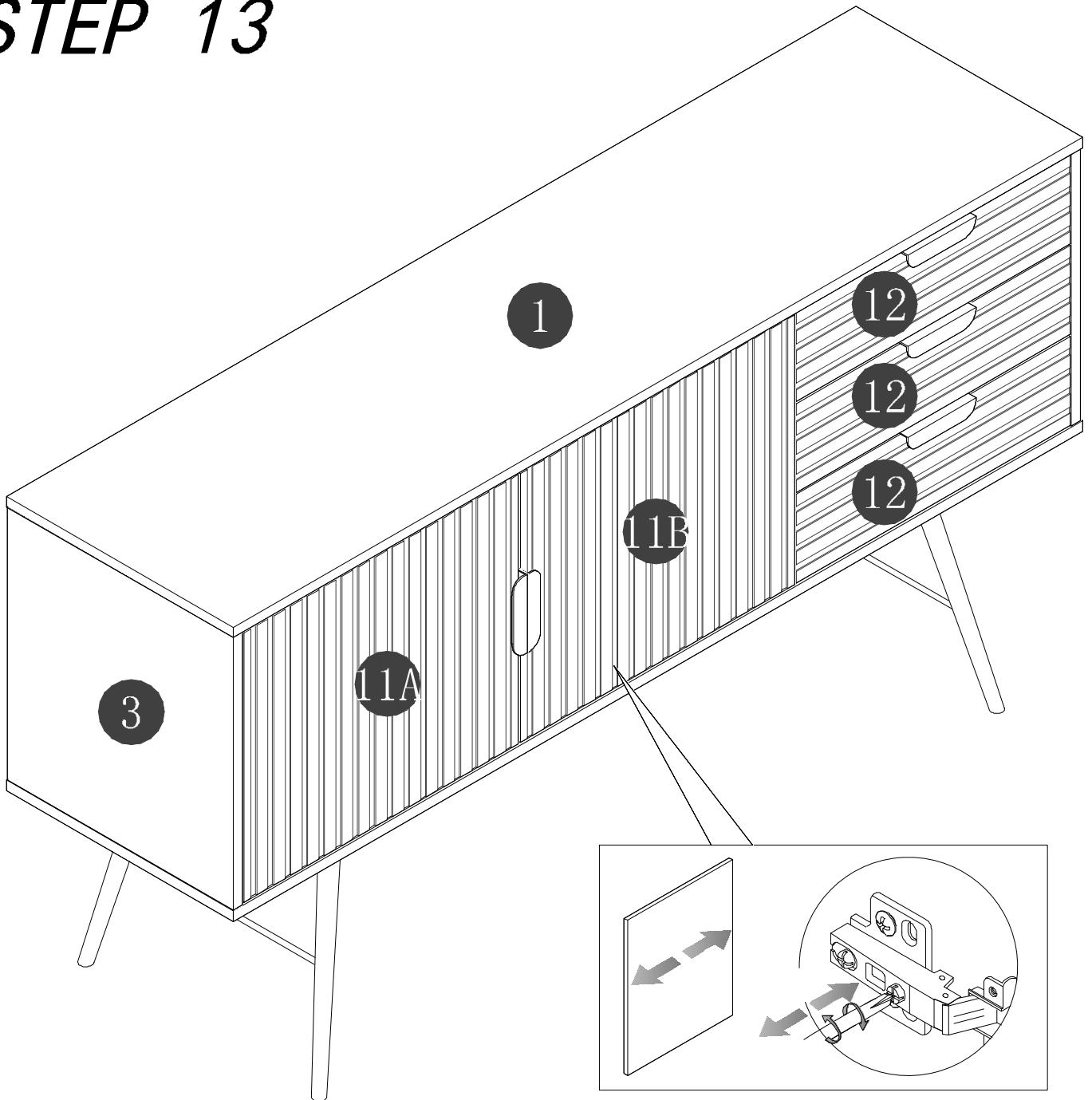

# STEP 14

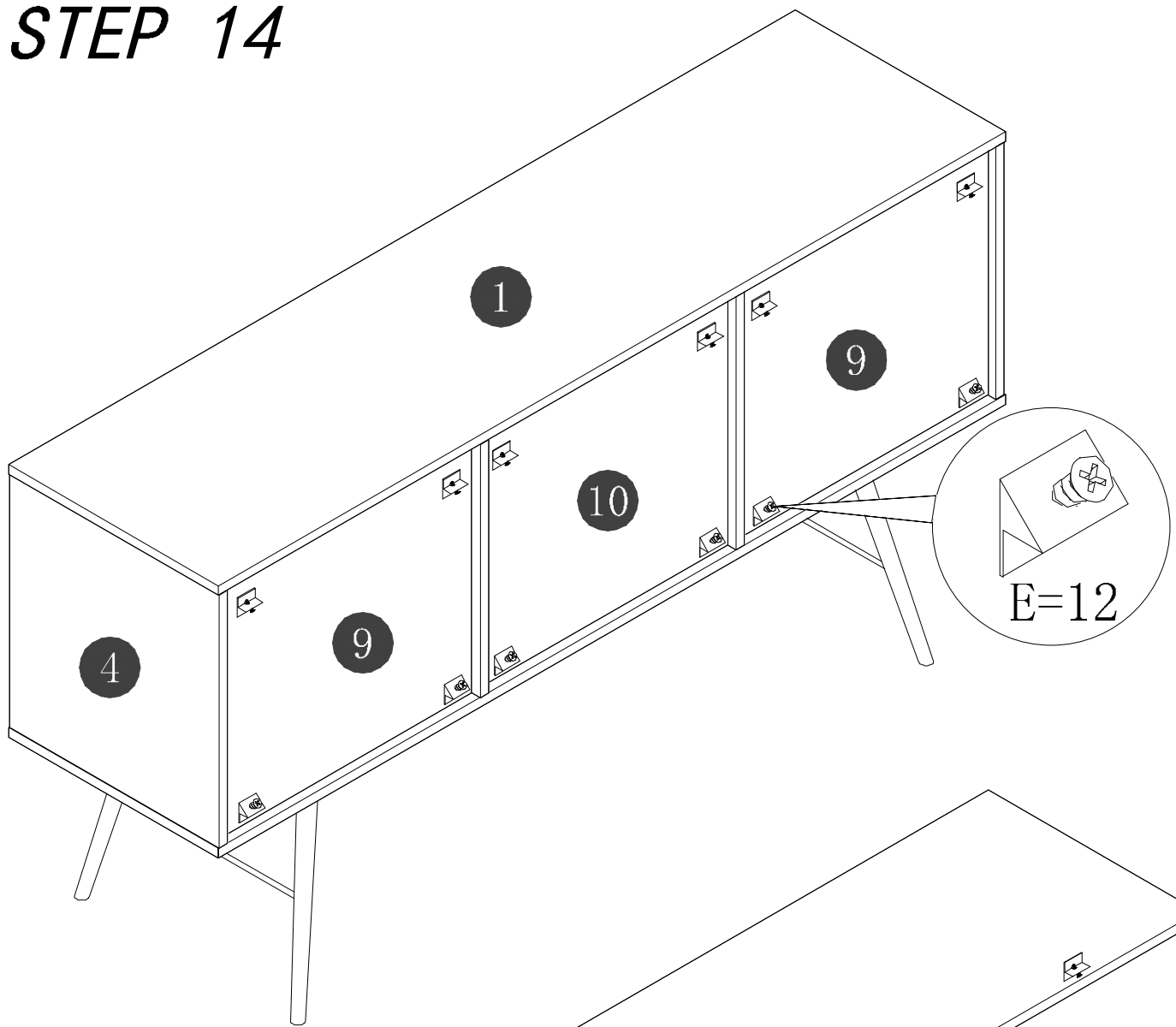

# STEP 15

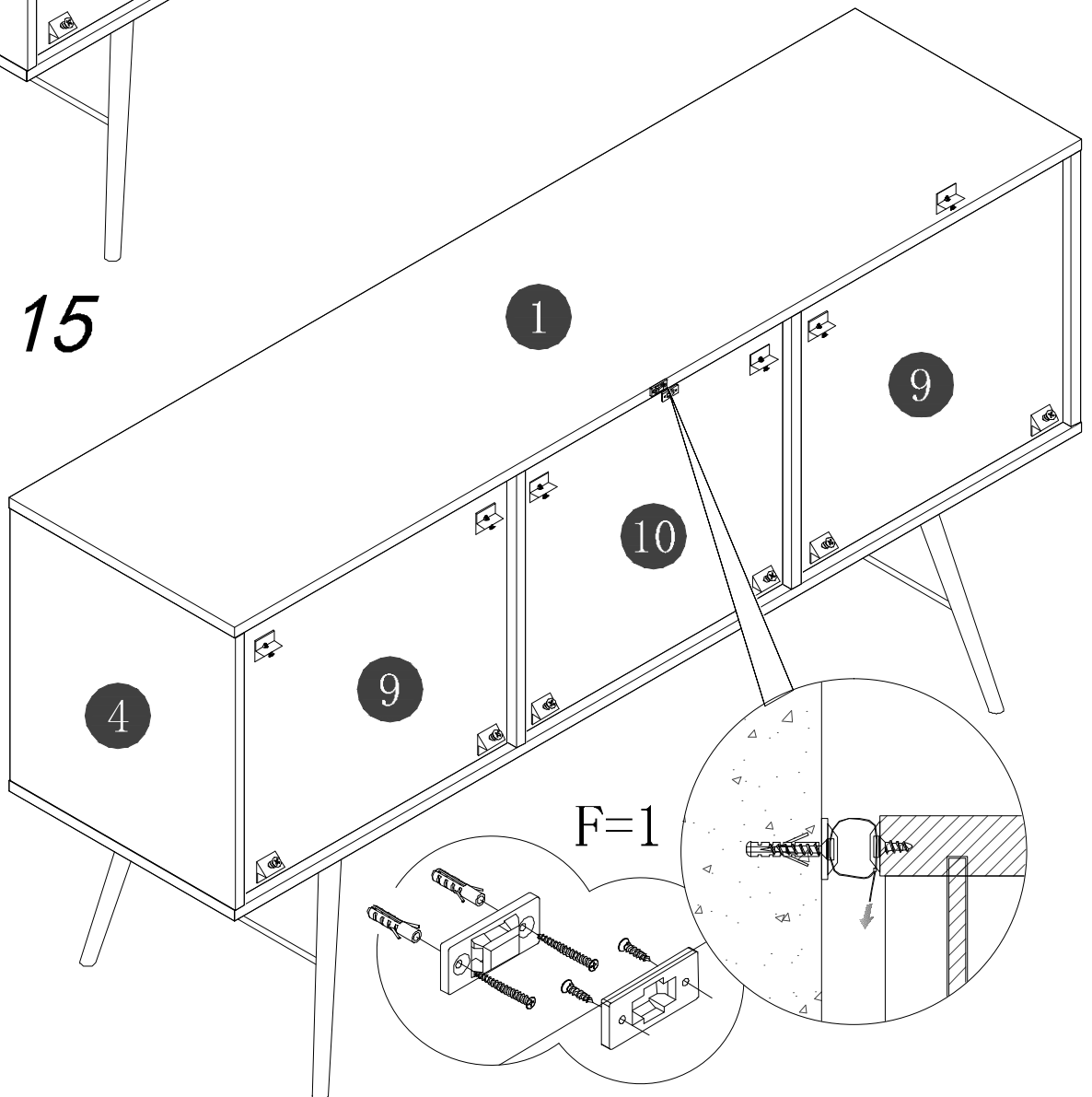

# STEP 16

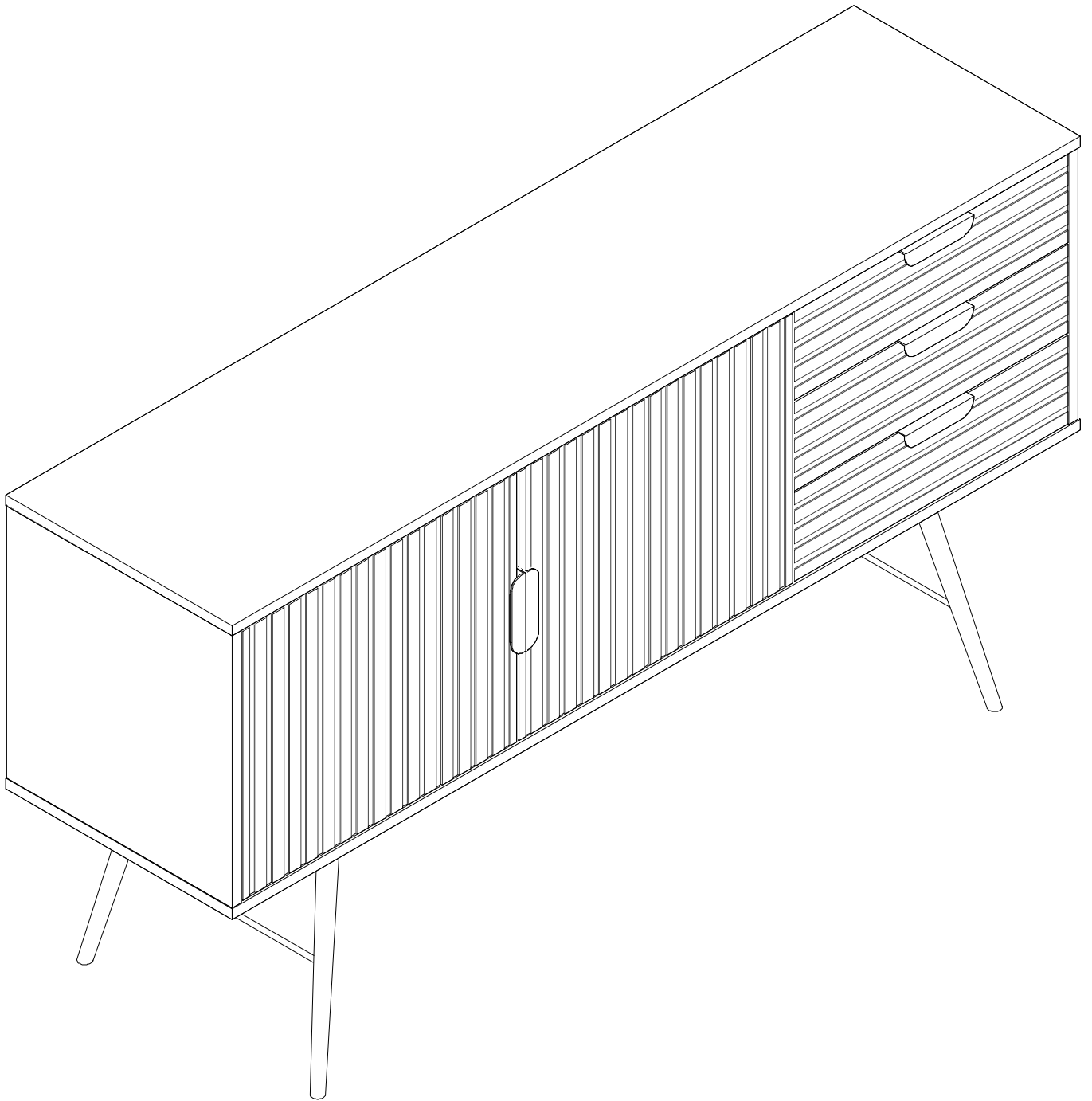

*Finish*

# 皮克斯餐边柜邮购包装图

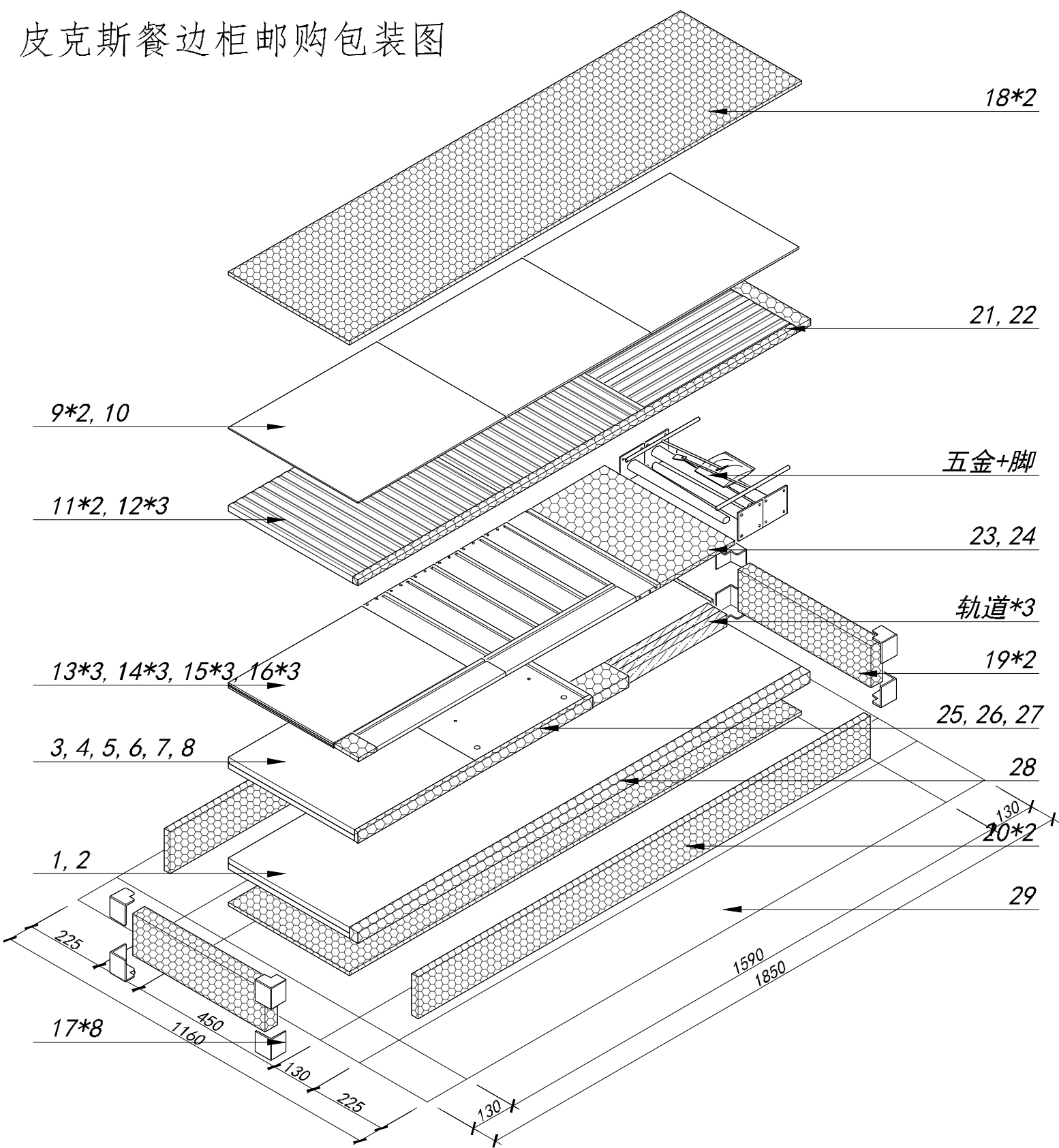

Panel No		Panel Sizes	Quantity
17	护角	50*50*50	8
18	泡沫	1500*430*10	2
19	泡沫	440*120*40	2
20	泡沫	1500*120*20	2
21	泡沫	430*45*15	1
22	泡沫	1454*10*15	1
23	泡沫	430*245*10	1

Panel No		Panel Sizes	Quantity
24	泡沫	80*58*10	1
25	泡沫	350*15*10	1
26	泡沫	120*80*30	1
27	泡沫	778*32*10	1
28	泡沫	1500*32*30	1
29	纸盒	内径1590*450*130	1