

Assembly Instruction

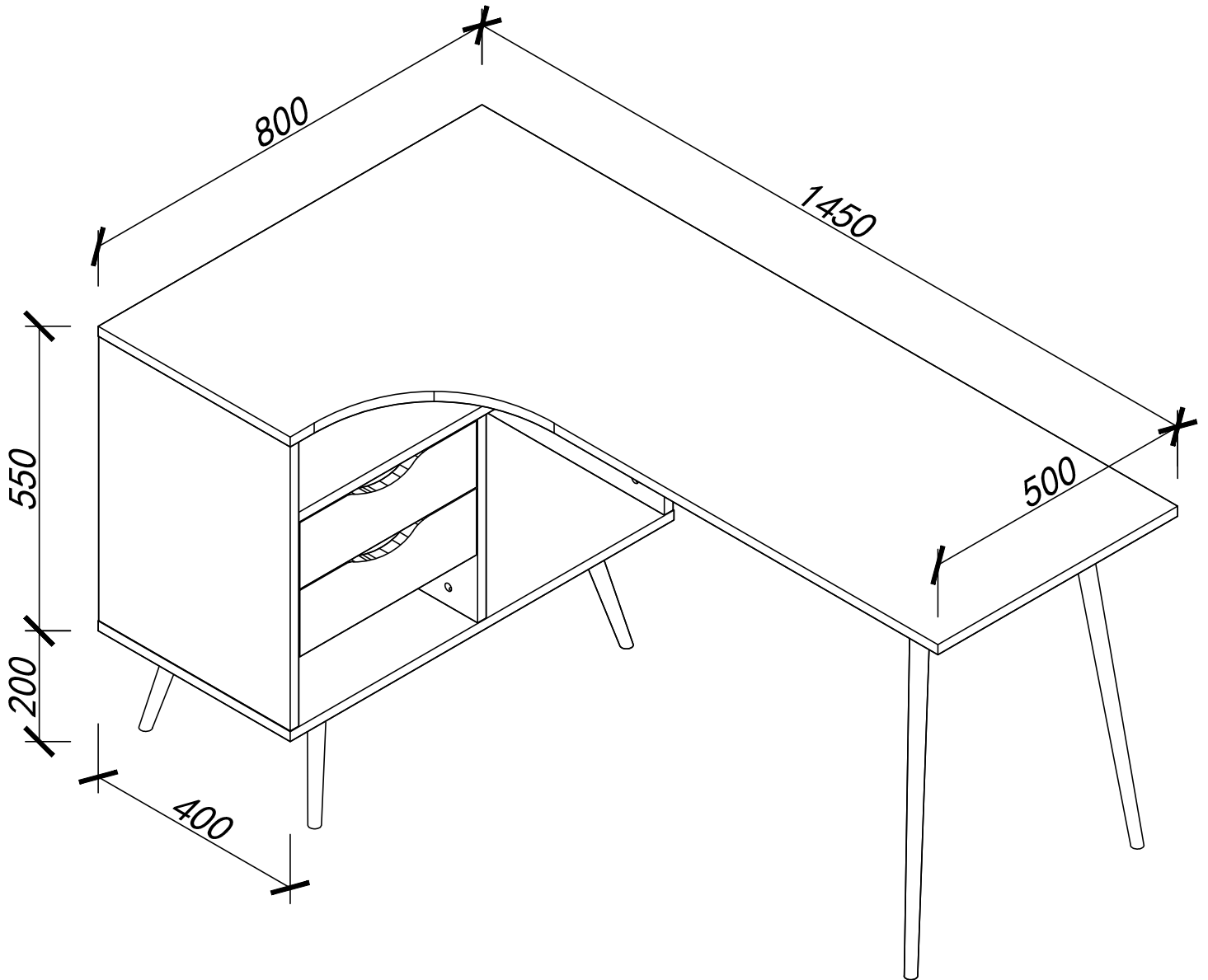

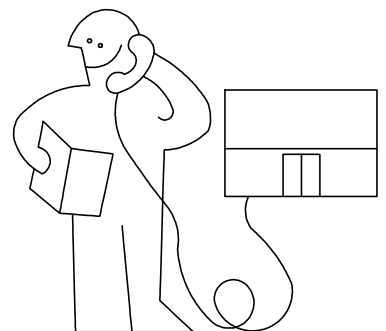
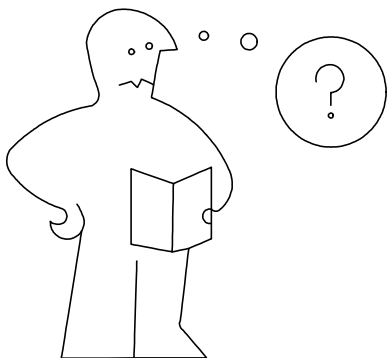
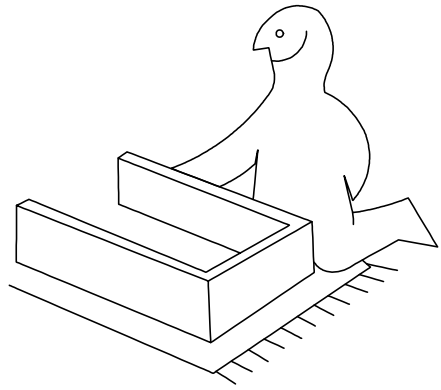
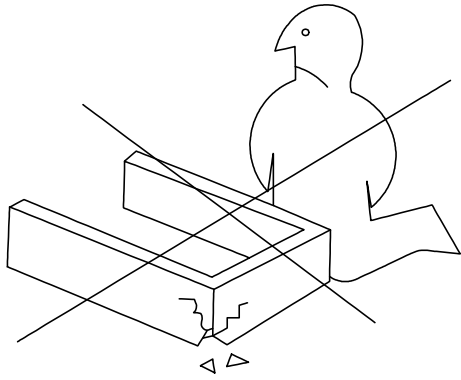
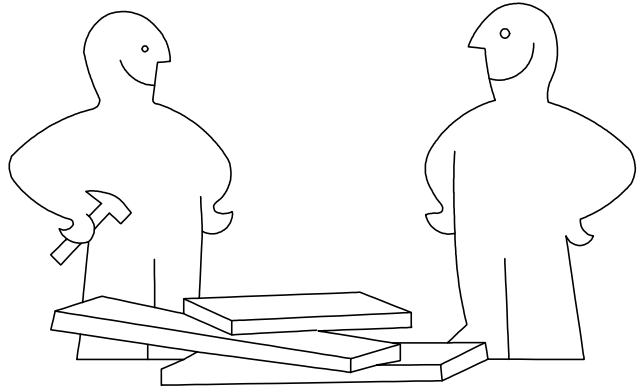
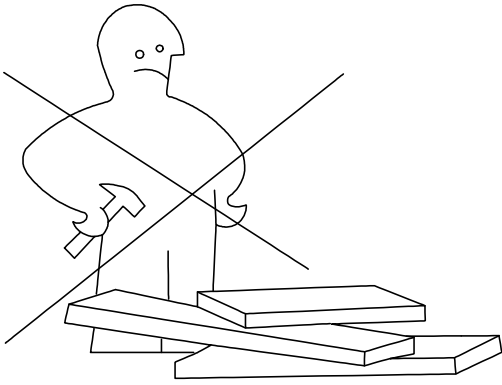
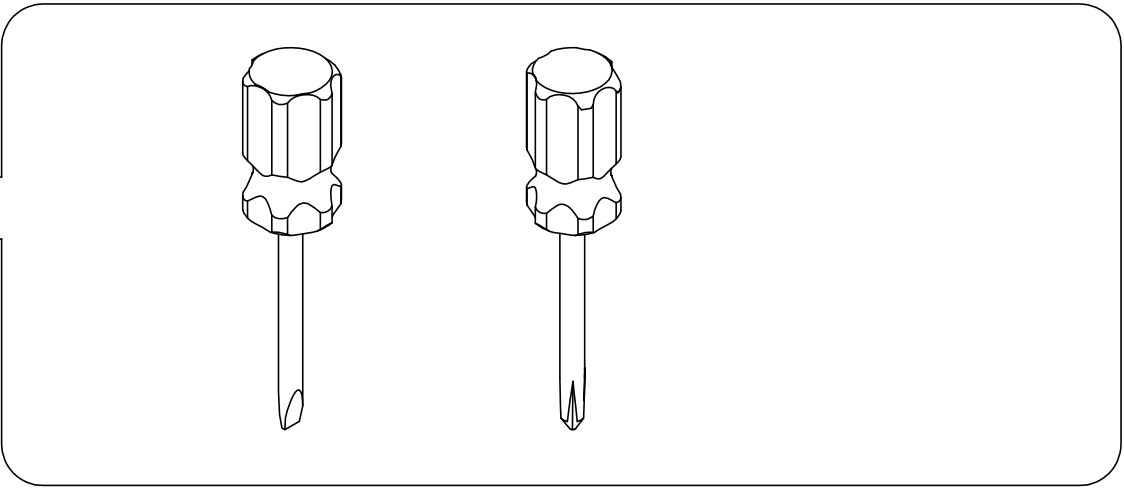
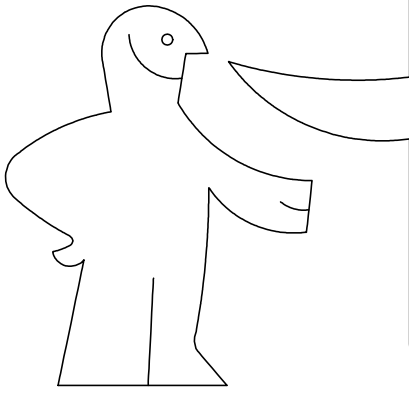

Panel No	Panel Sizes	Quantity
1	1450*800*18	1
2	800*400*18	1
3	514*399*18	1
4	514*399*18	1
5	368*379*18	1
6	762*399*18	1

Panel No	Panel Sizes	Quantity
7	772*378*5	1
8	368*120*18	2
9	322*80*12	2
10	350*80*12	2
11	350*80*12	2
12	332*348*5	2

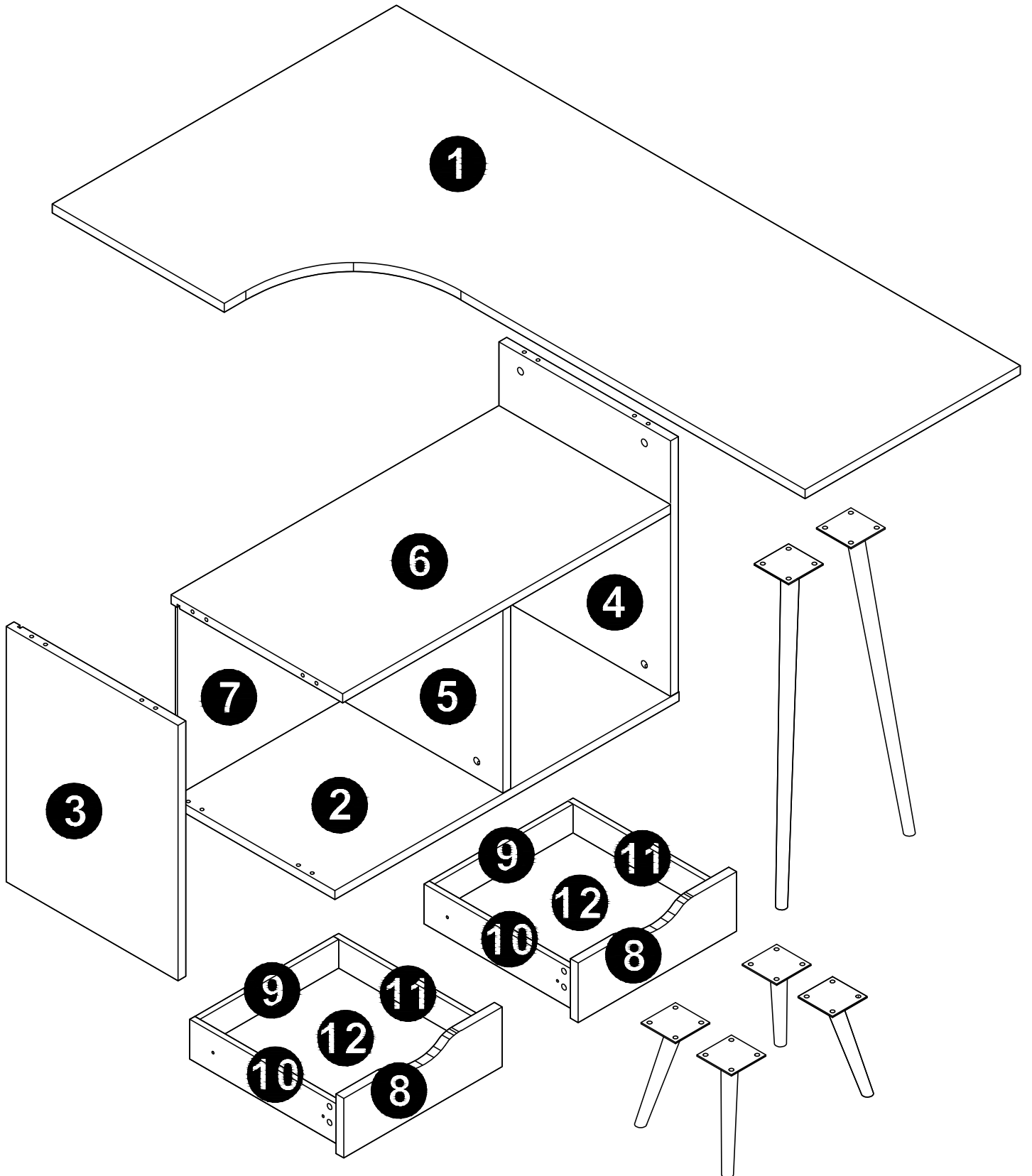

Fittings



A=16

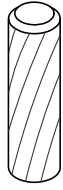

B=16



C=16



D1=16



D2=16



E=8



M8*16

G1=24



H=1

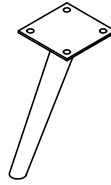

J-1=4

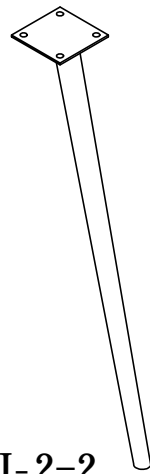

J-2=2

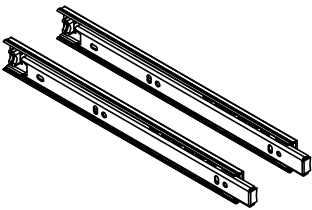

N=2



O=16



P=16



M8.5*12

V1=16



Z1=24



Z2=24

1

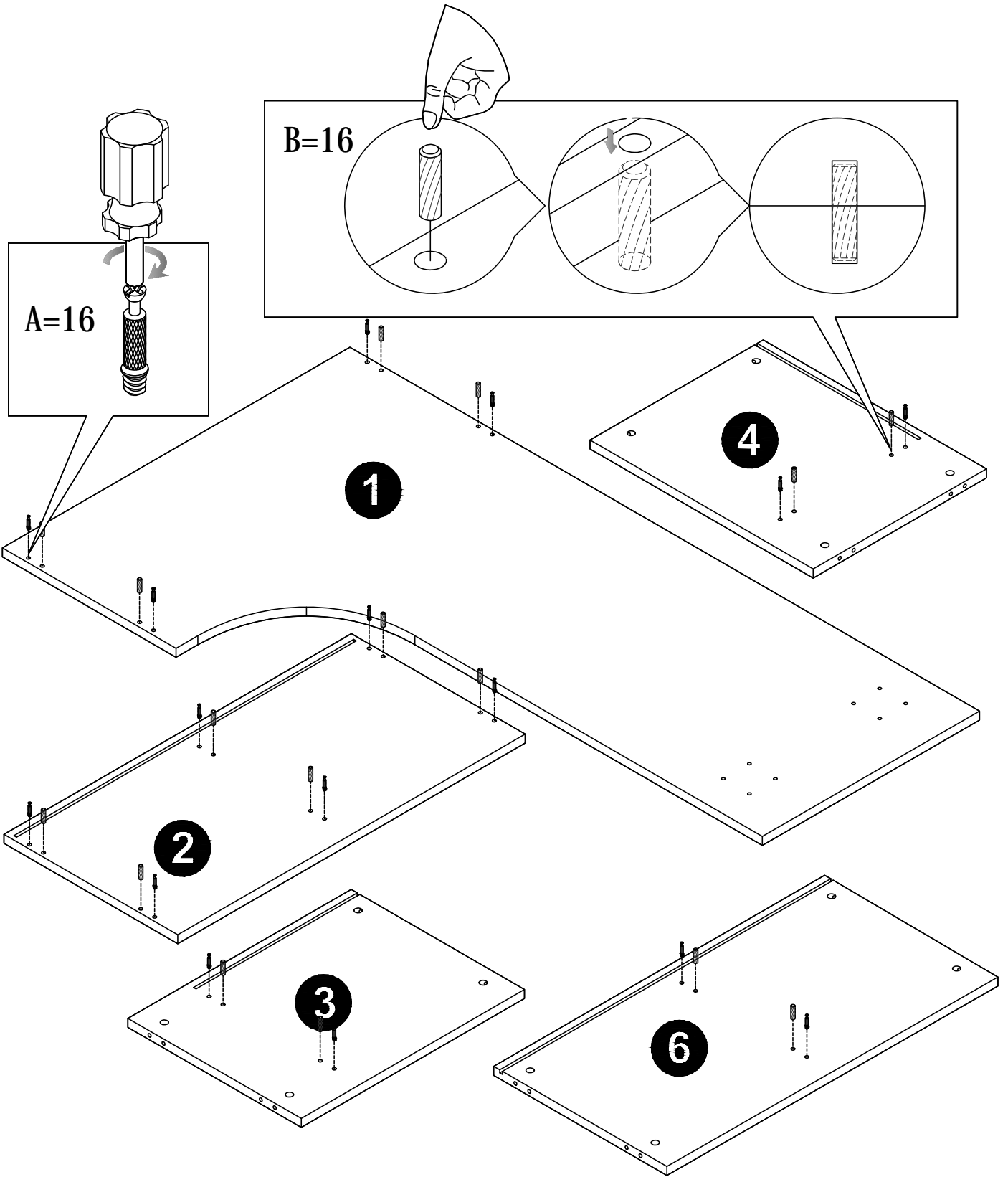

2

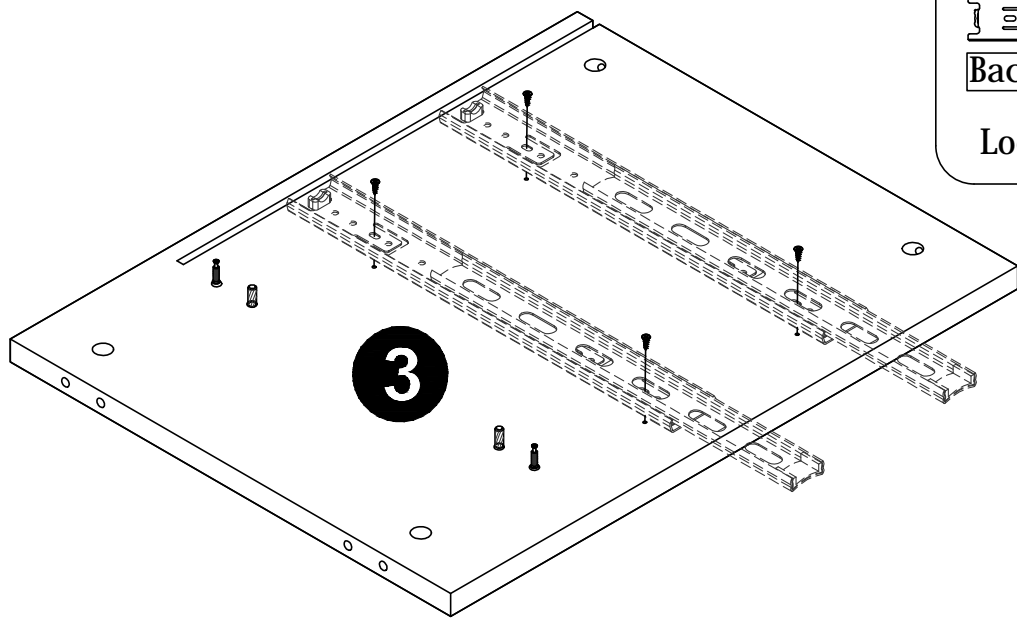
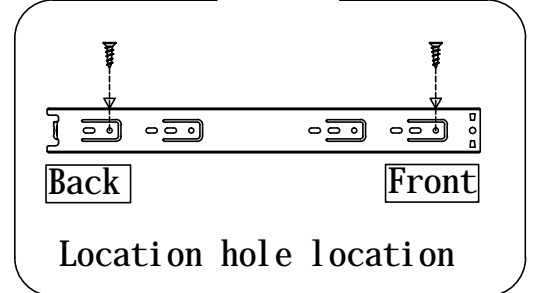
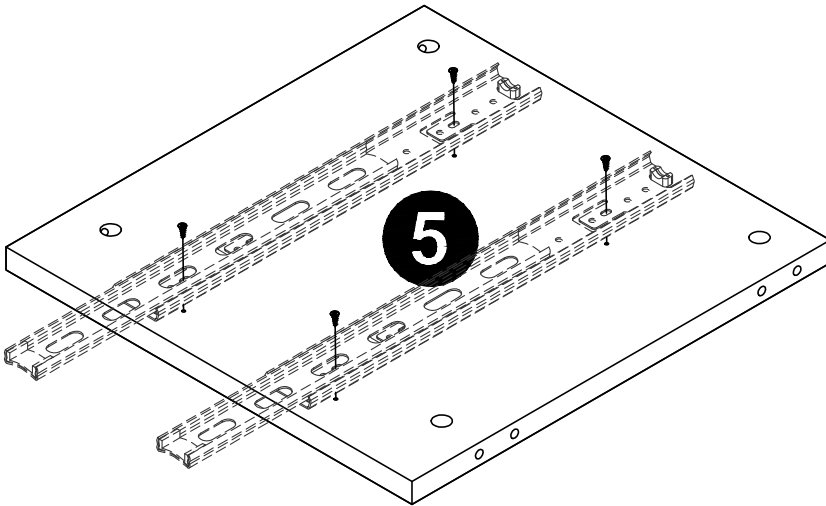
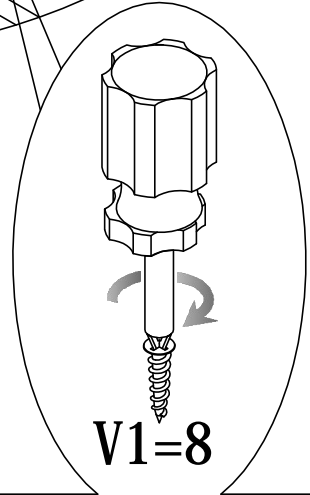
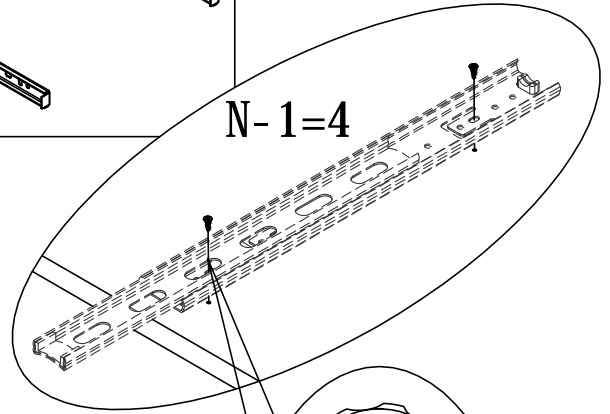
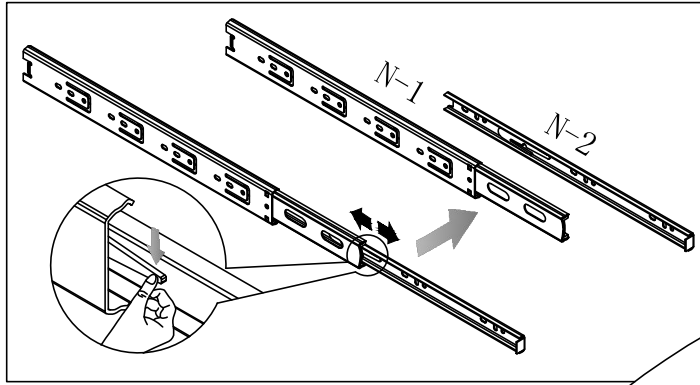

3

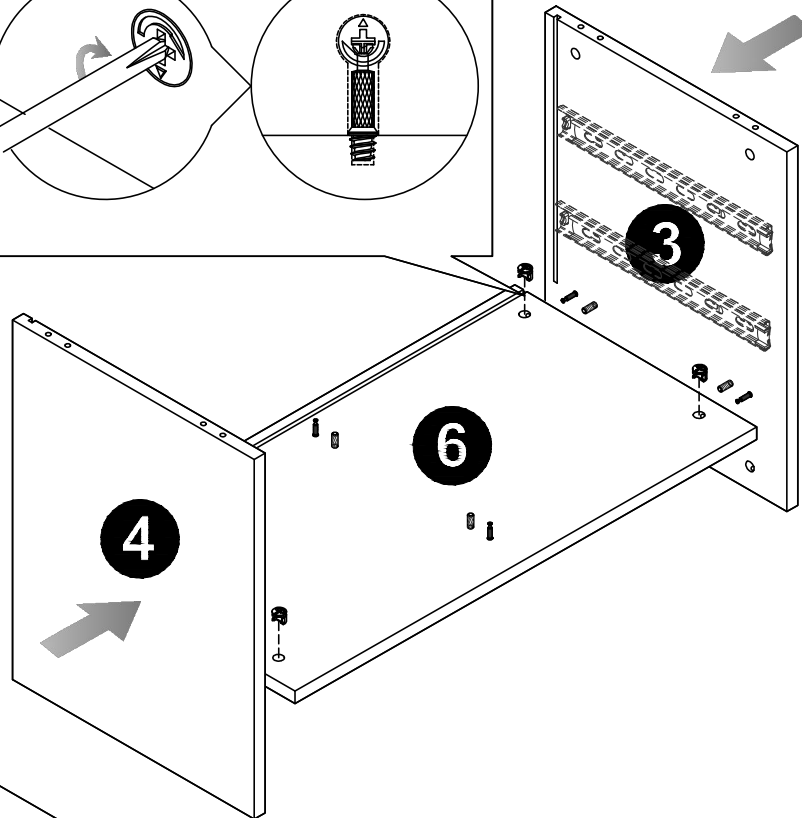
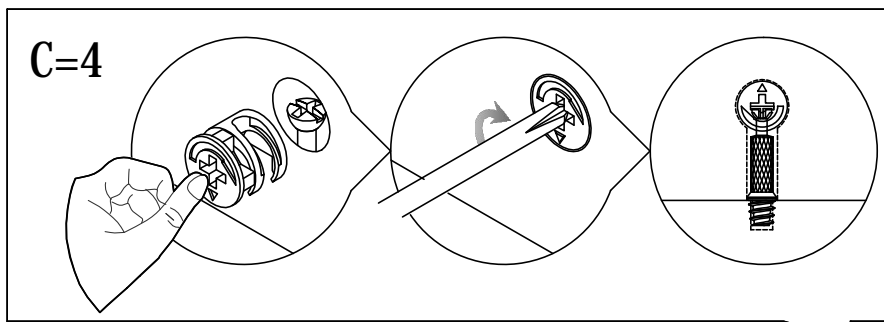

4

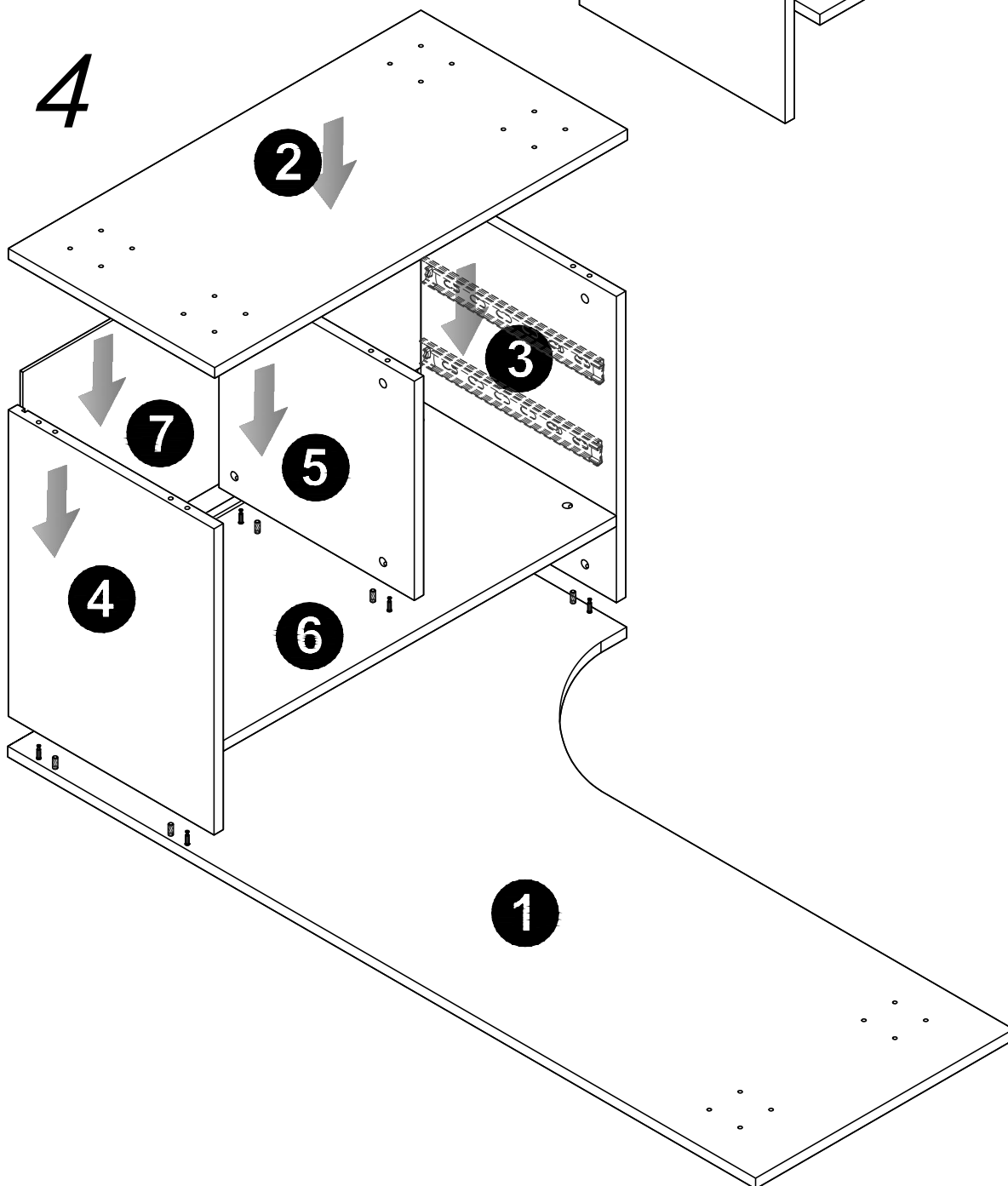

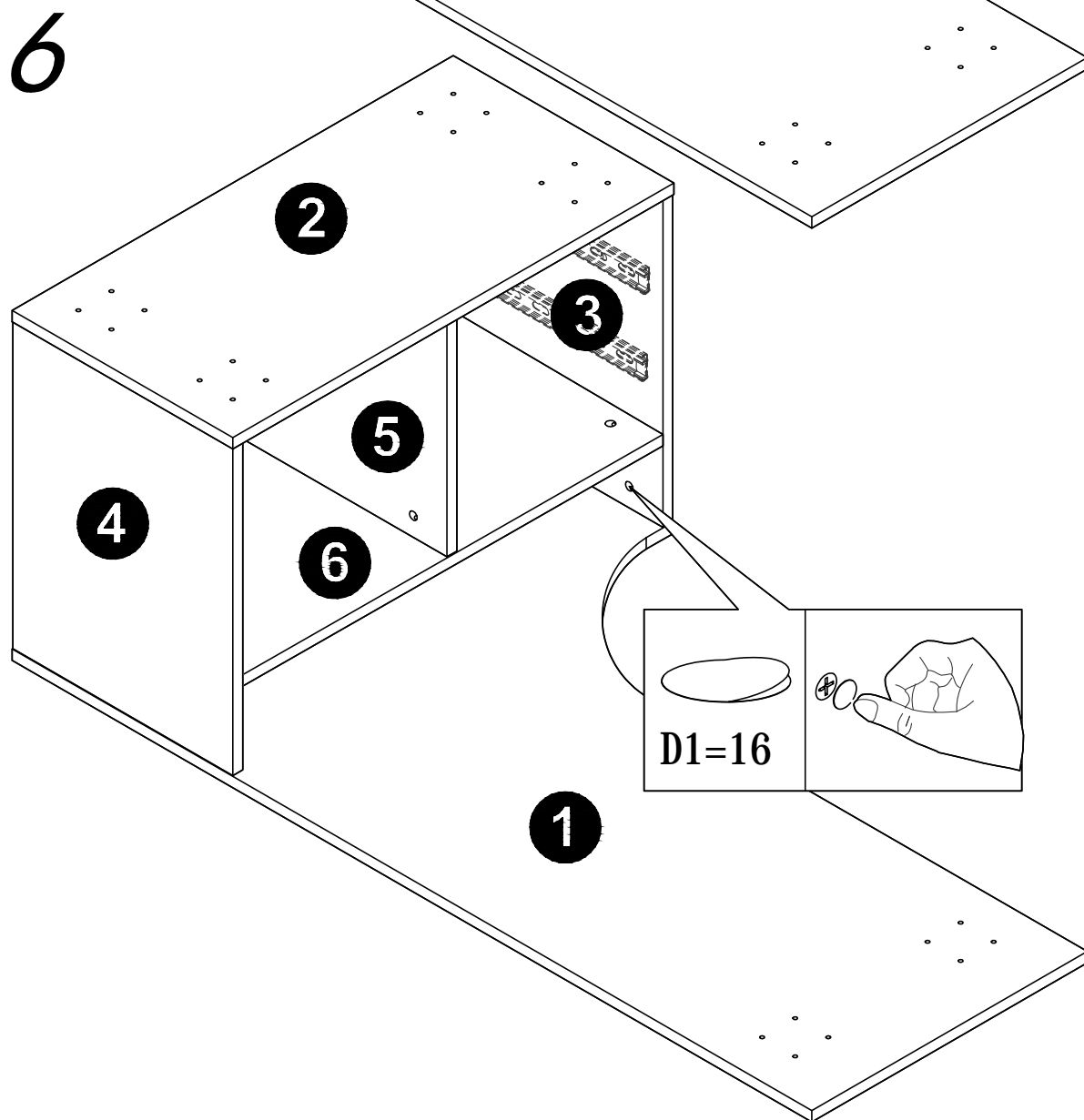
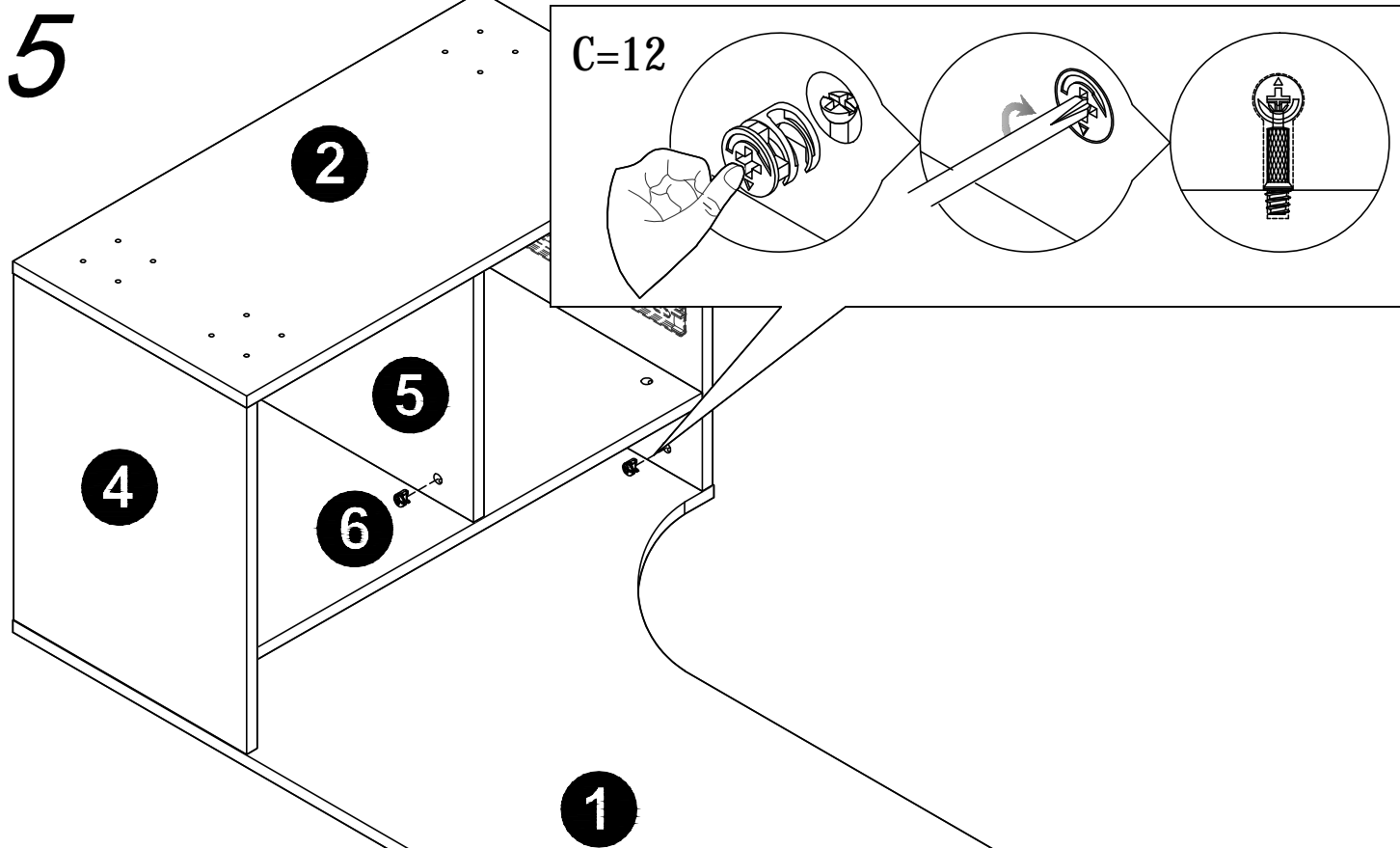

7

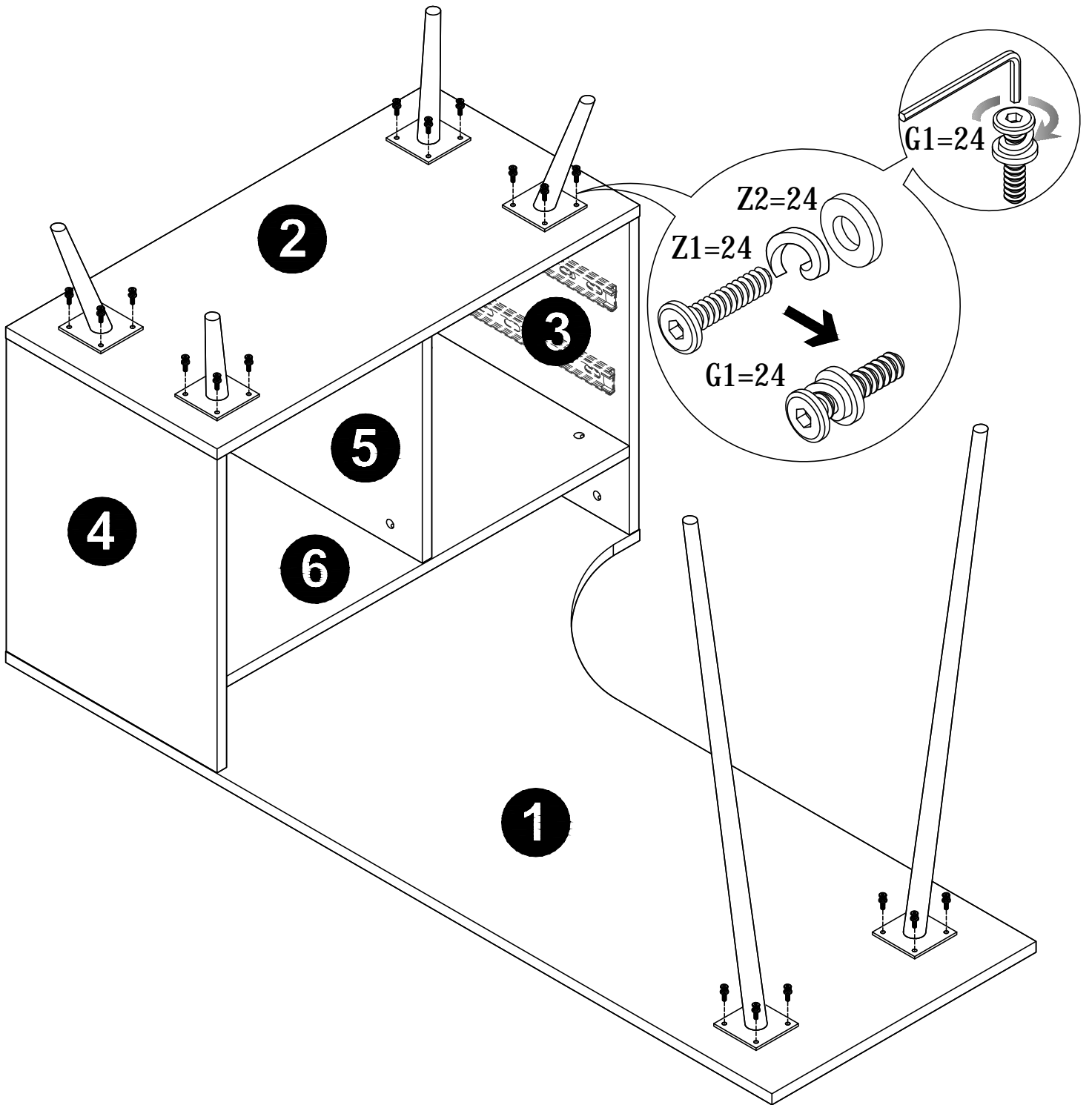

8

8-1

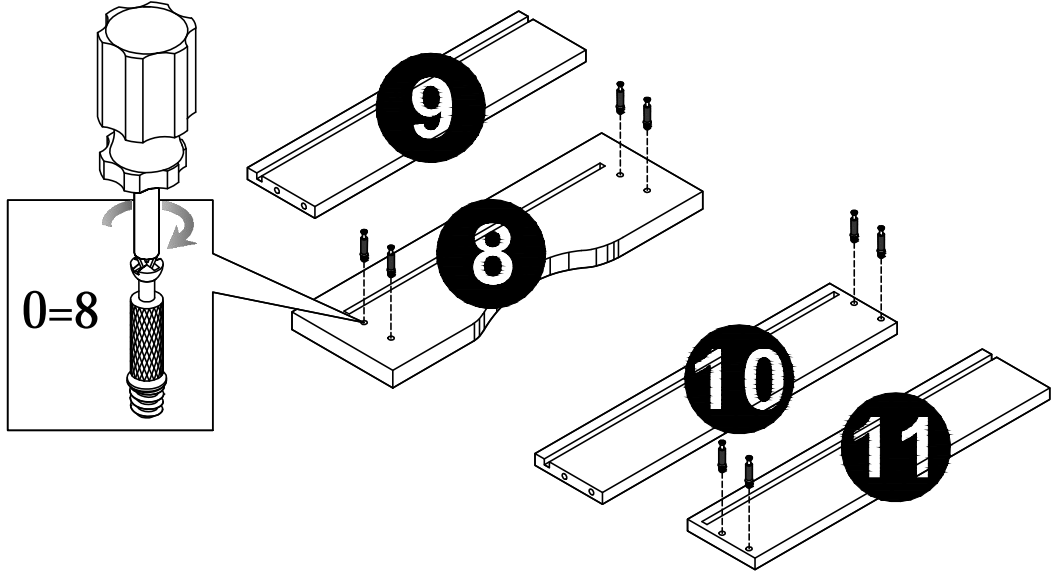

8-2

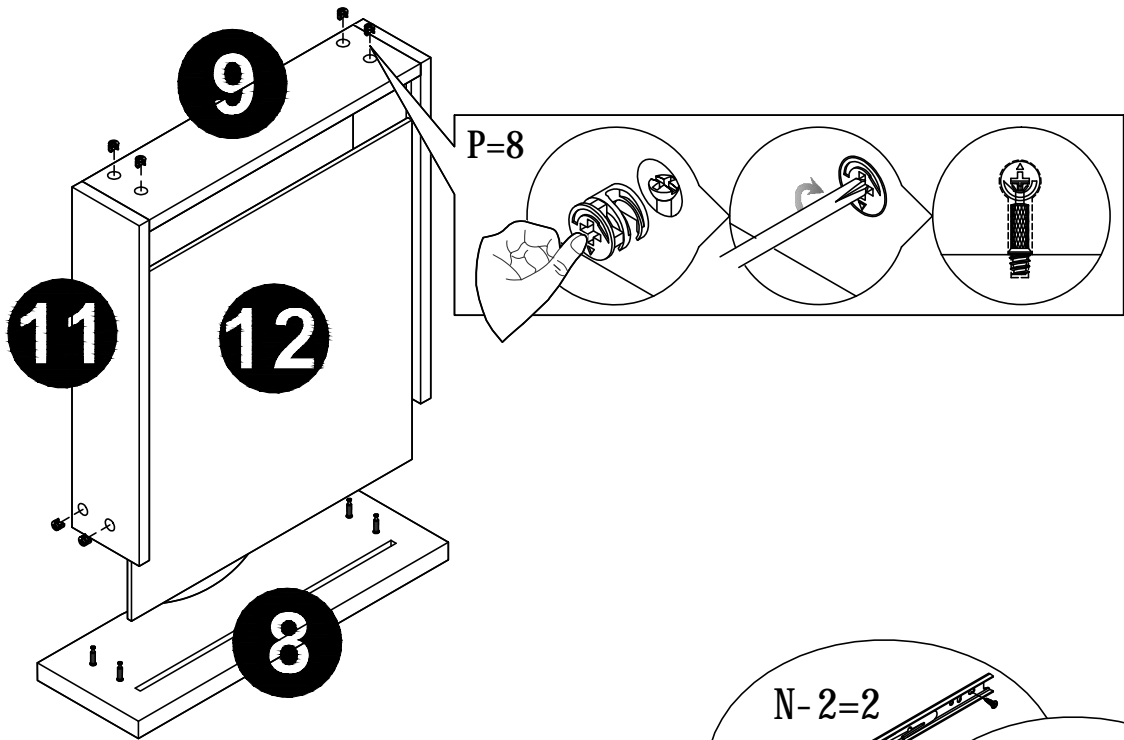

8-3

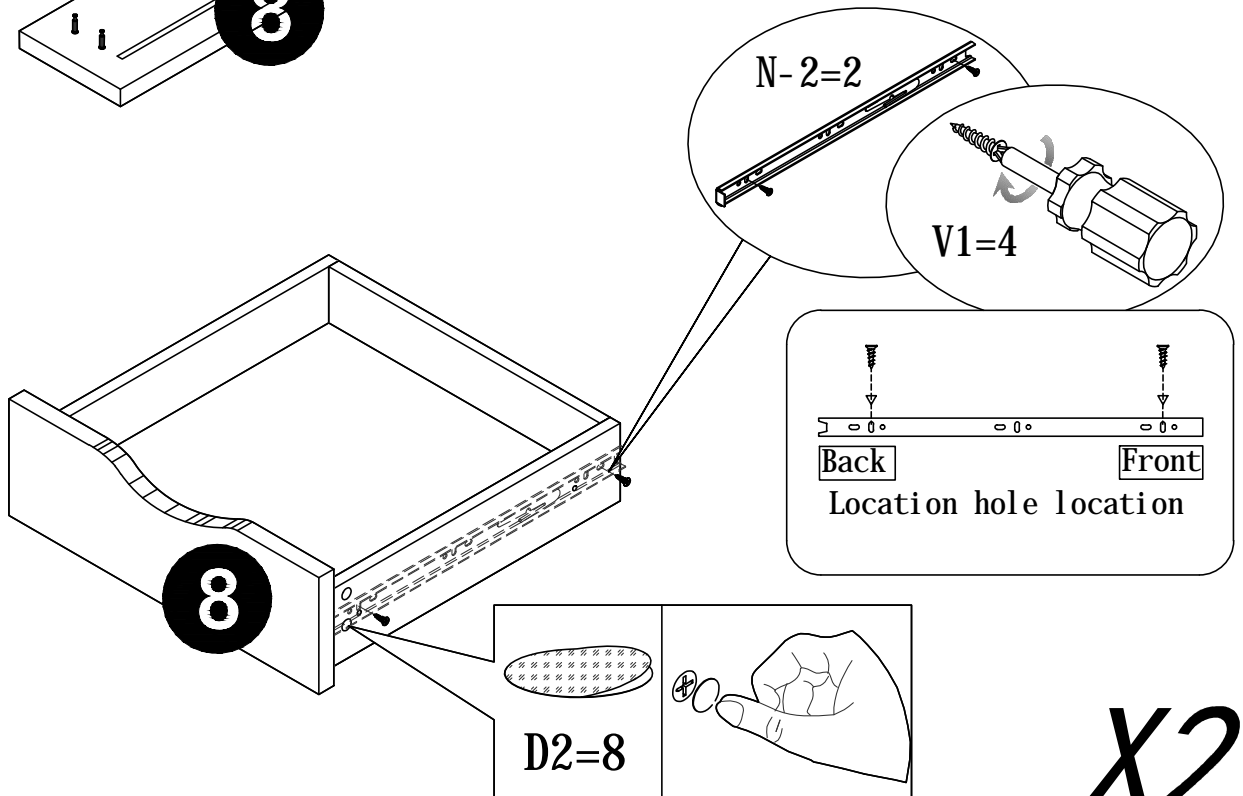

X2

9

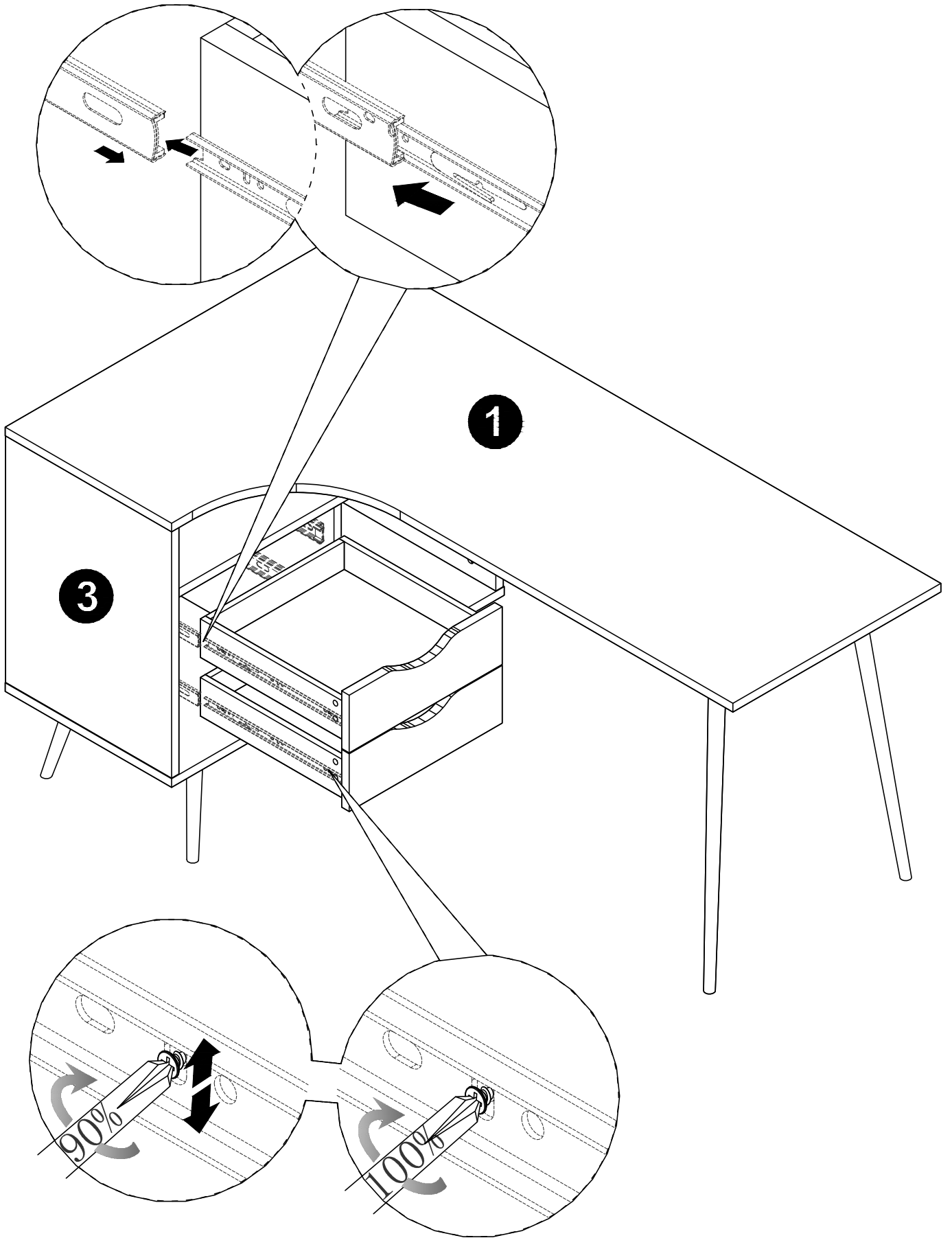

10

