

Assembly Instruction

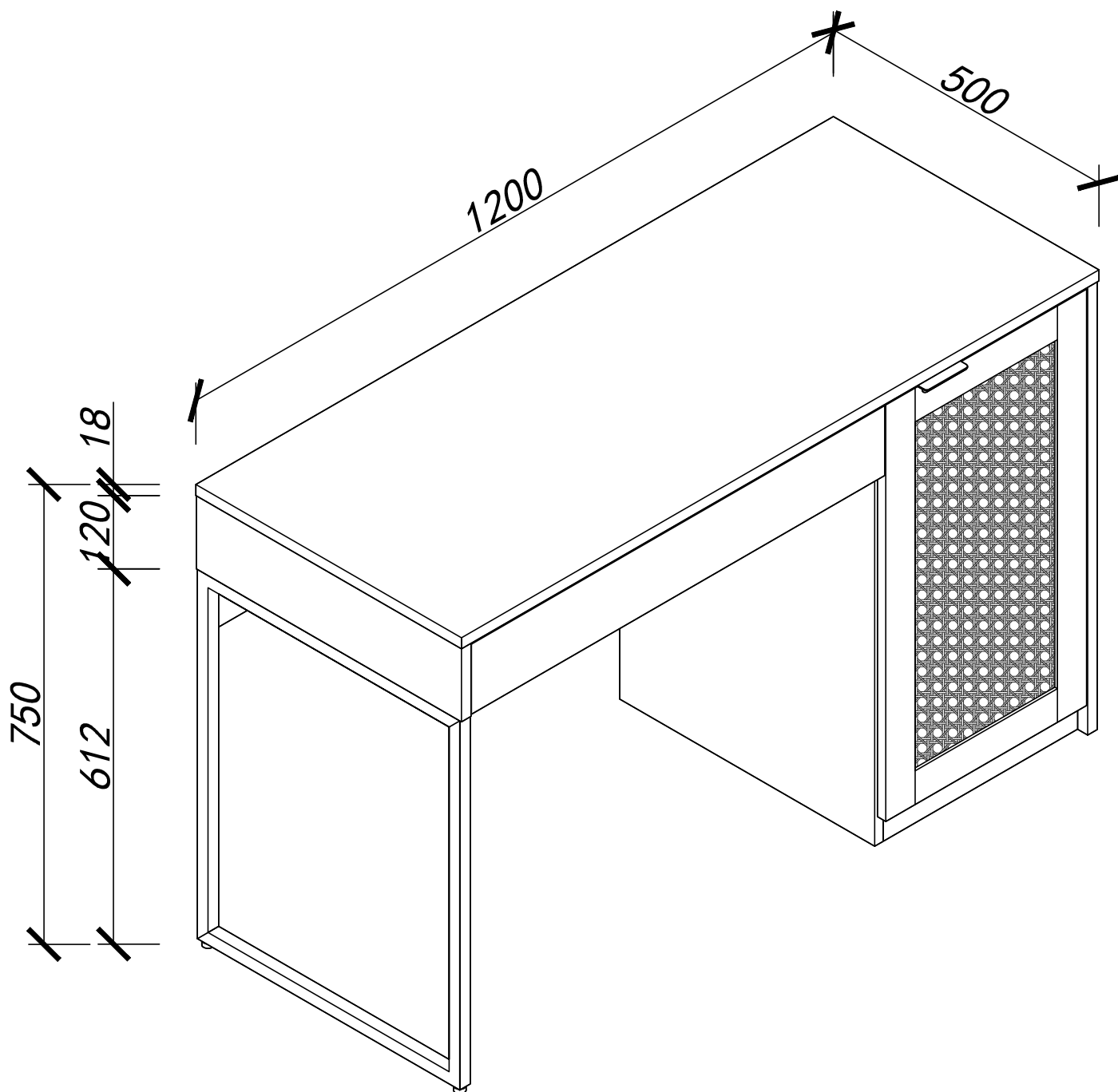

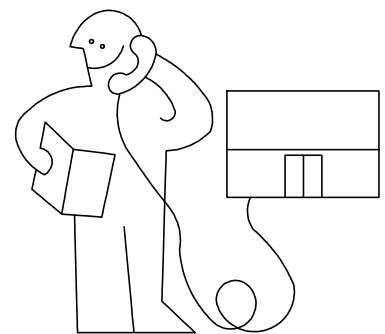
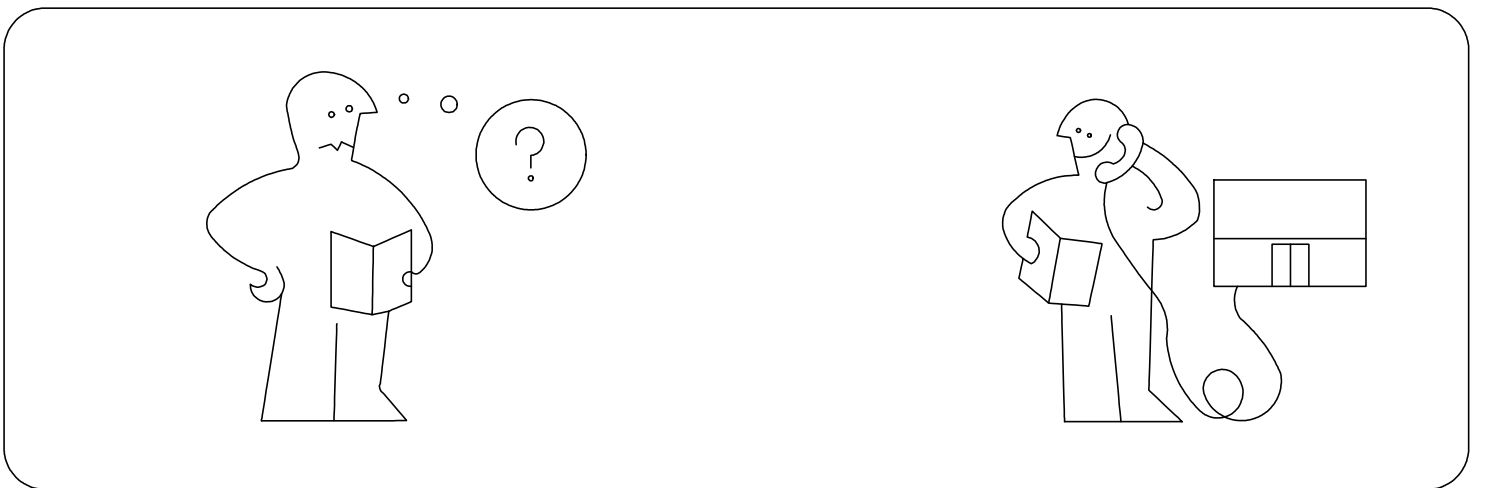
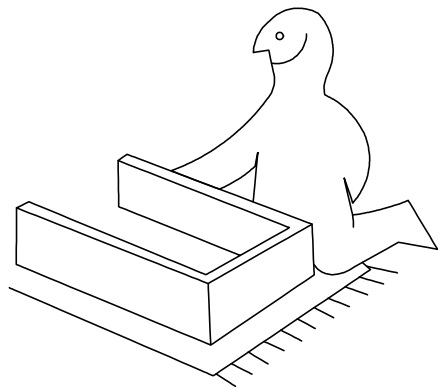
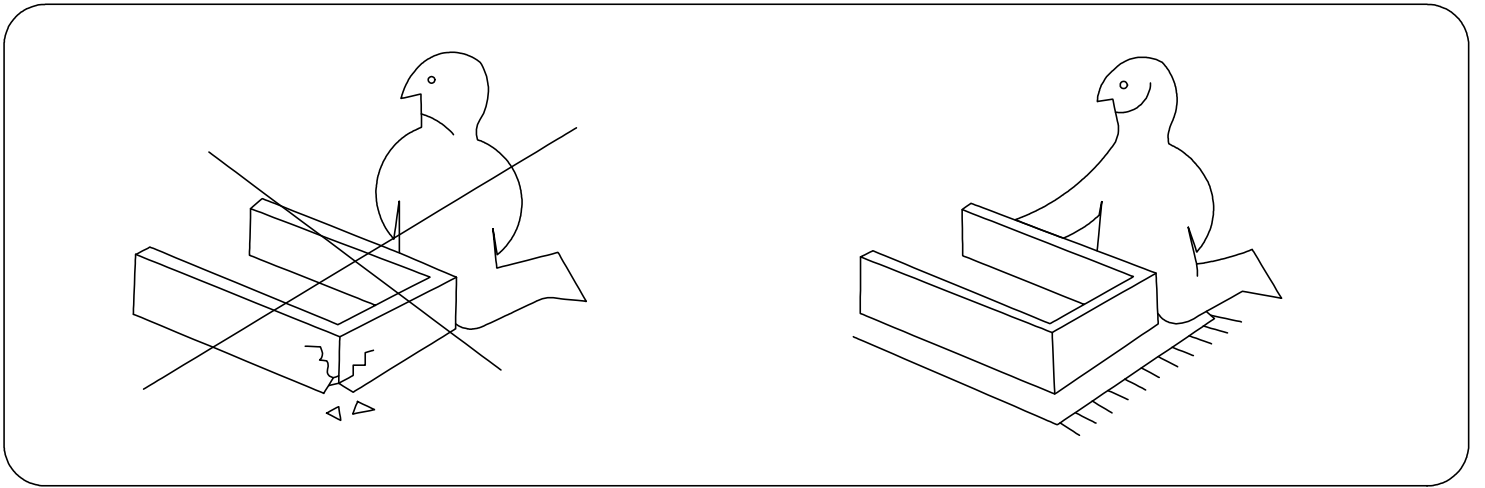
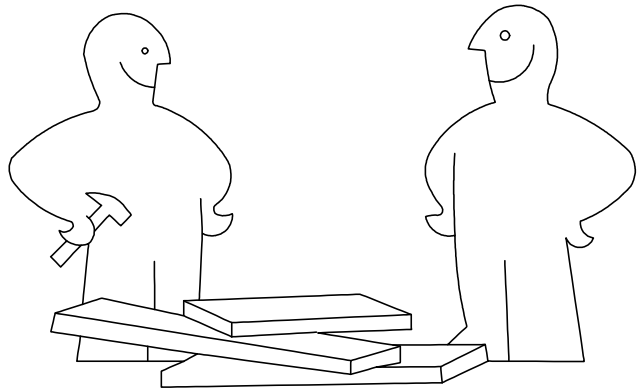
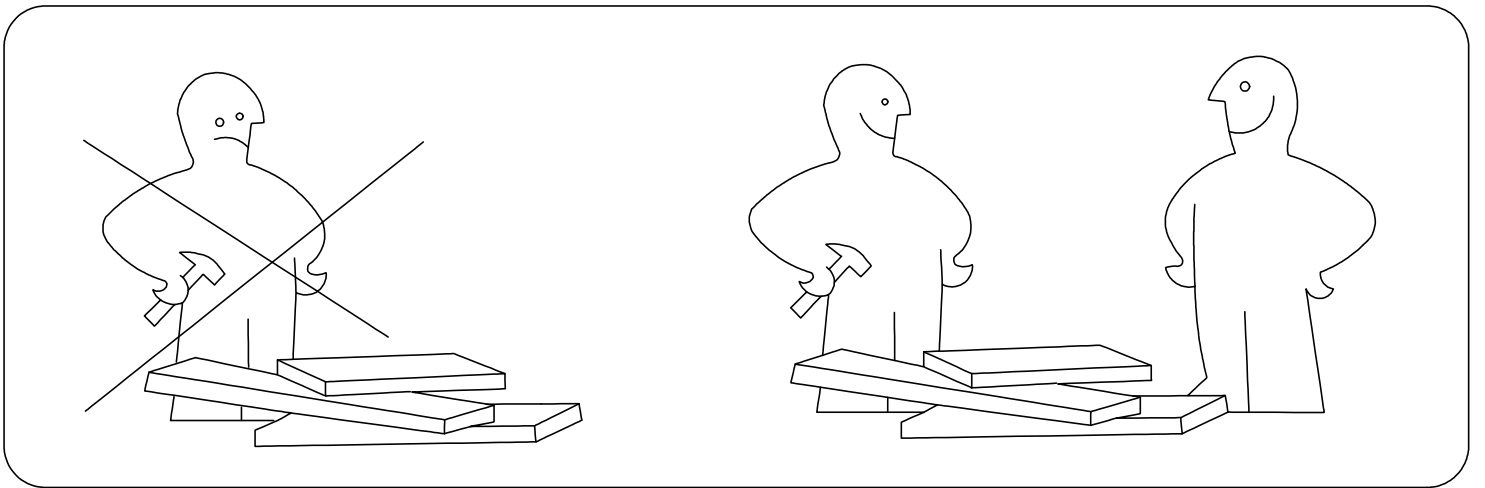
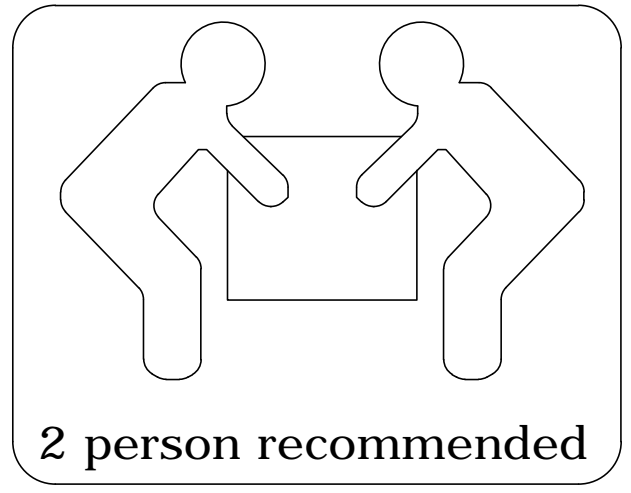
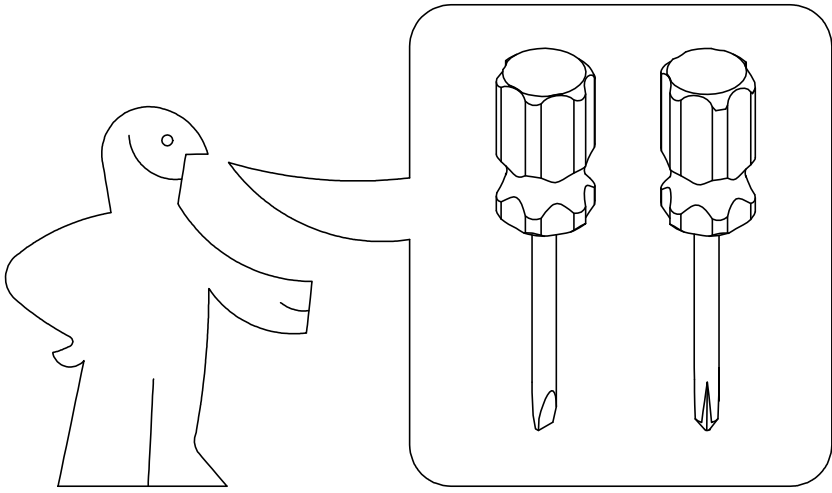

Panel No	Panel Sizes	Quantity
1	1200*500*16	1
2	782*460*16	1
3	368*481*16	1
4	122*499*16	1
5	729*499*16	1
6	729*482*16	1
7	776*100*16	1
8	116*792*5	1
9	673*378*5	2

Panel No	Panel Sizes	Quantity
10	676*382*16	1
11	365*440*16	1
12	778*116*16	1
13	732*80*12	1
14	400*80*12	1
15	400*80*12	1
16	742*398*5	1
17	387*100*12	1
18	367*50*16	2

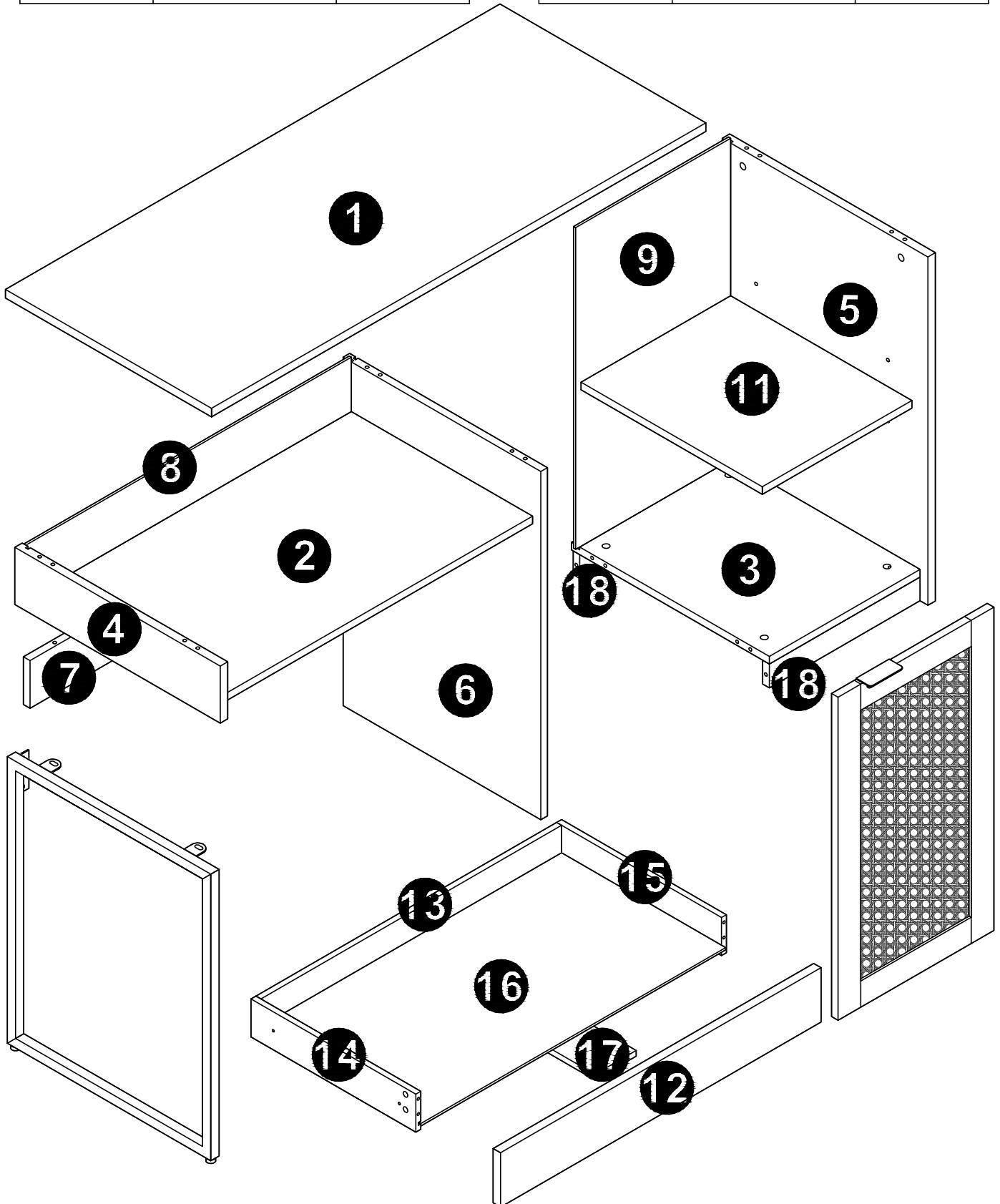

Fittings

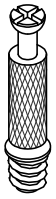

A=25

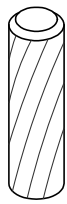

B=16

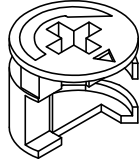

C=25



D=35

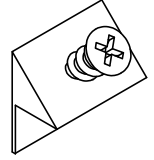

E=10

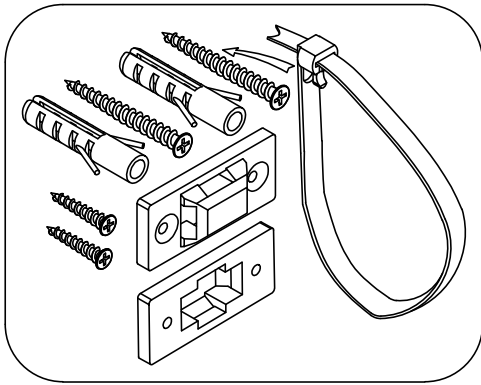

F=1

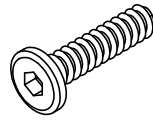

M6*16

G1=4



H=1

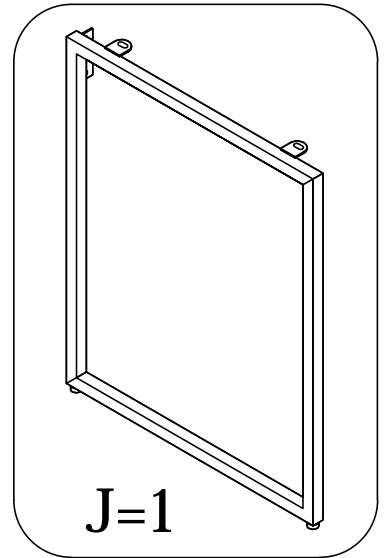

J=1

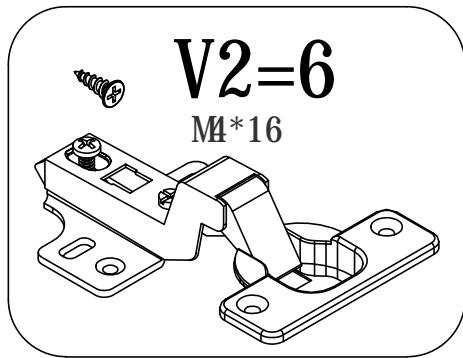

V2=6

M6*16

I3=2

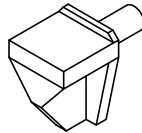

L=4

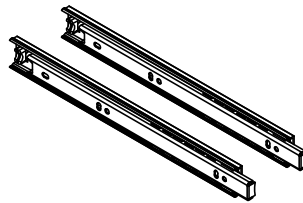

N=1



O=10



P=10

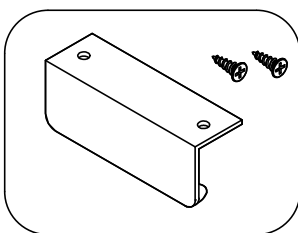

U=1



M6. 5*12

V1=8



Z1=4

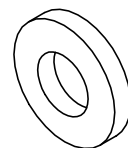

Z2=4

STEP 1

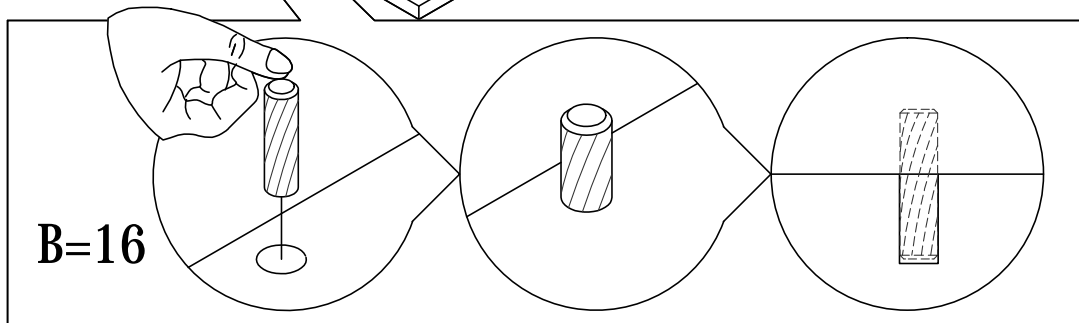
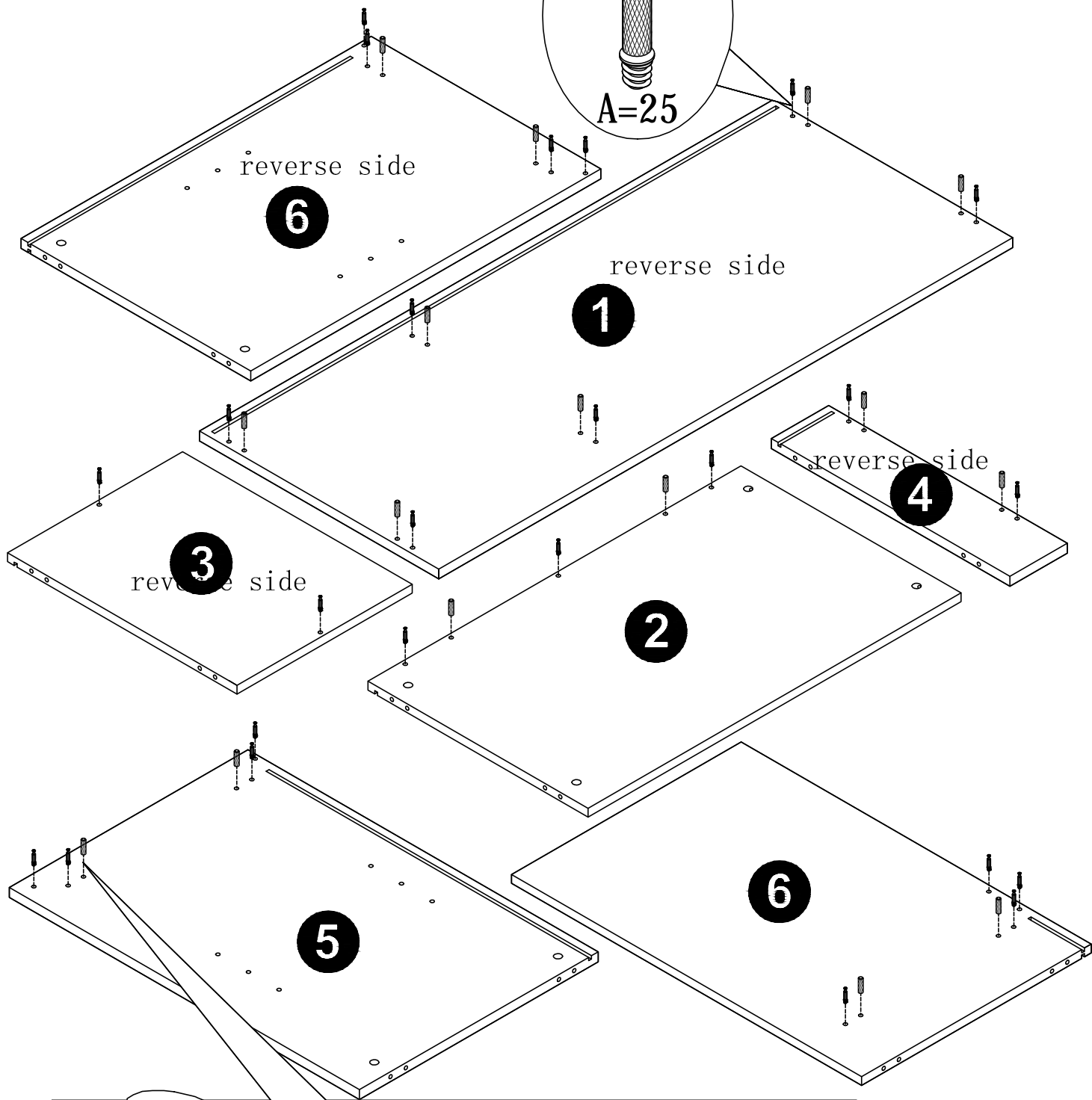
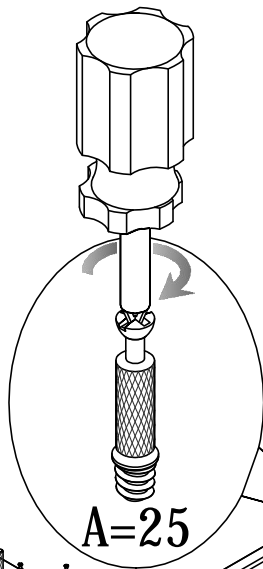

STEP 2

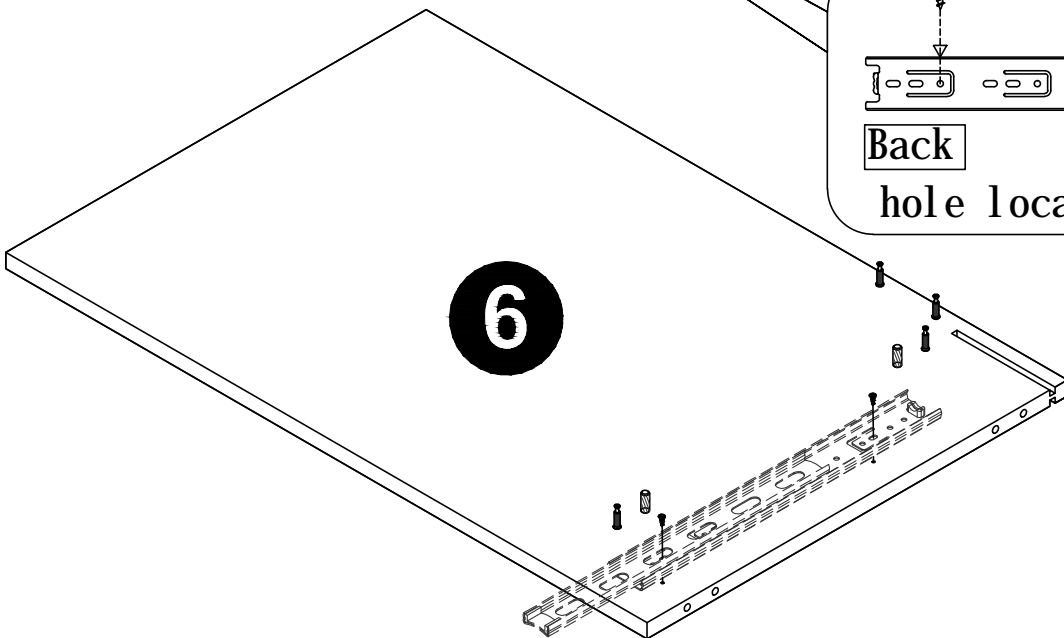
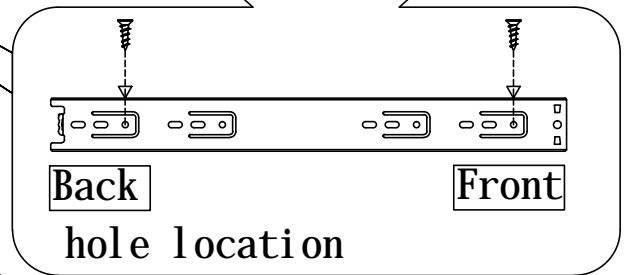
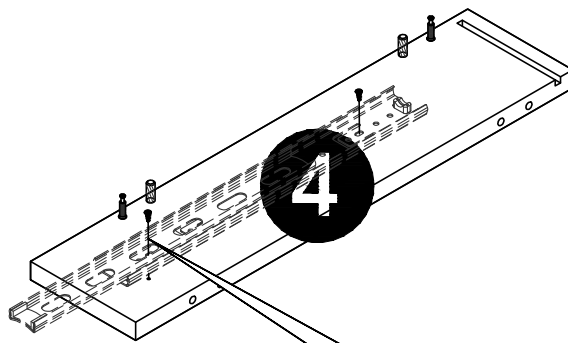
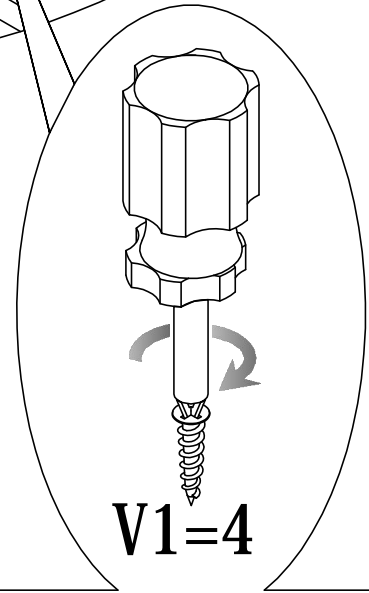
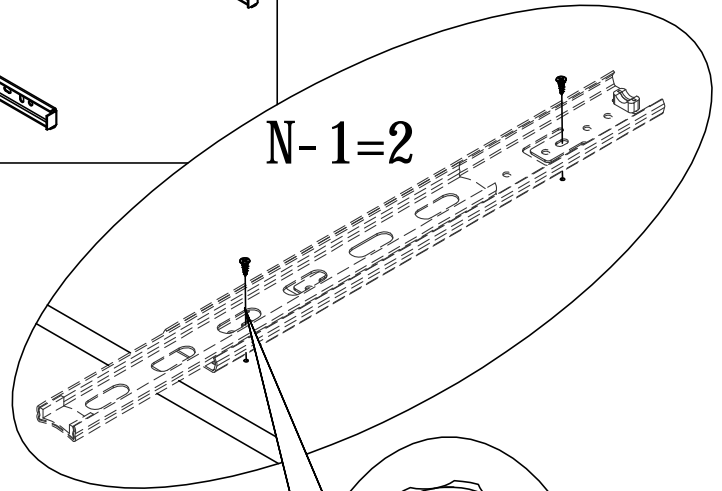
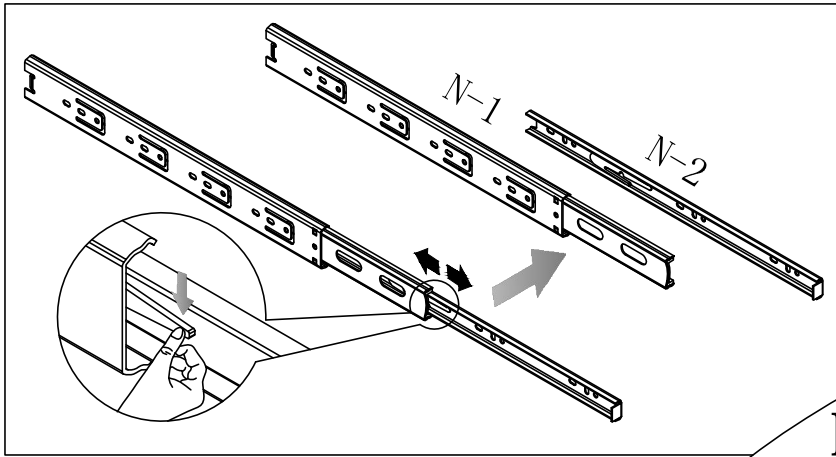

STEP 3

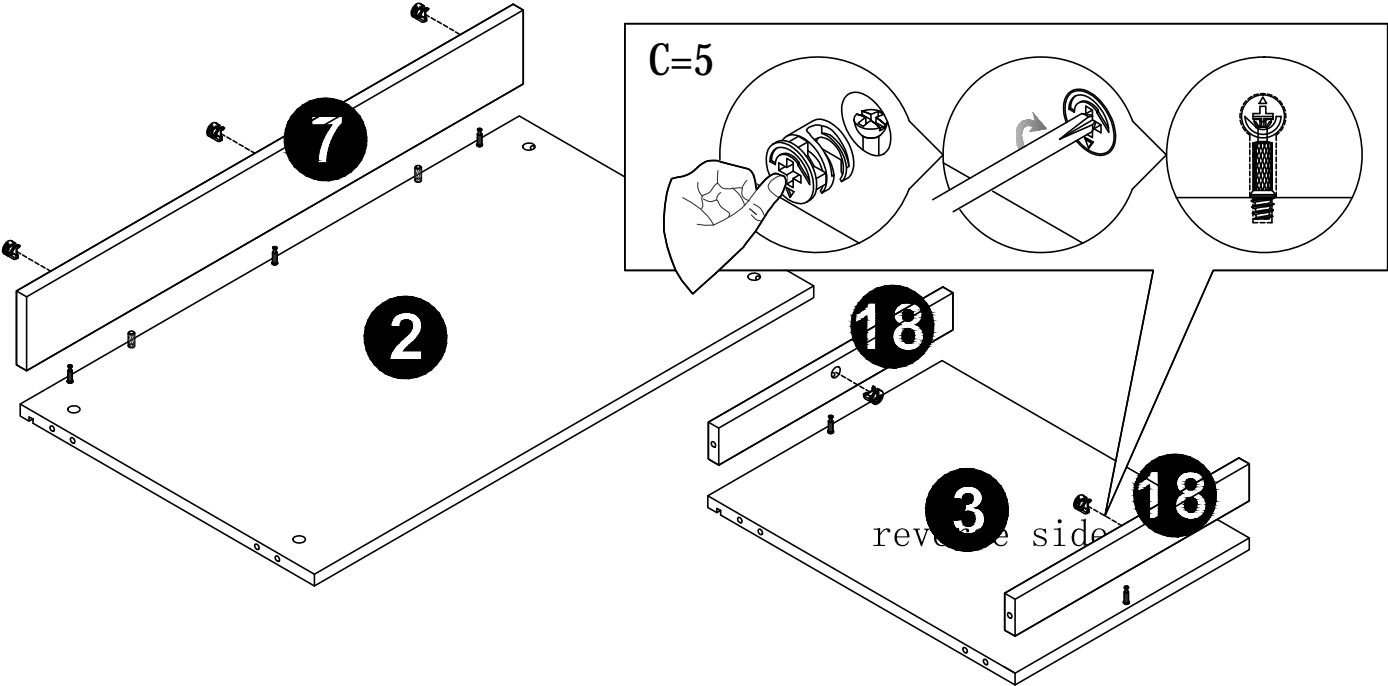

STEP 4

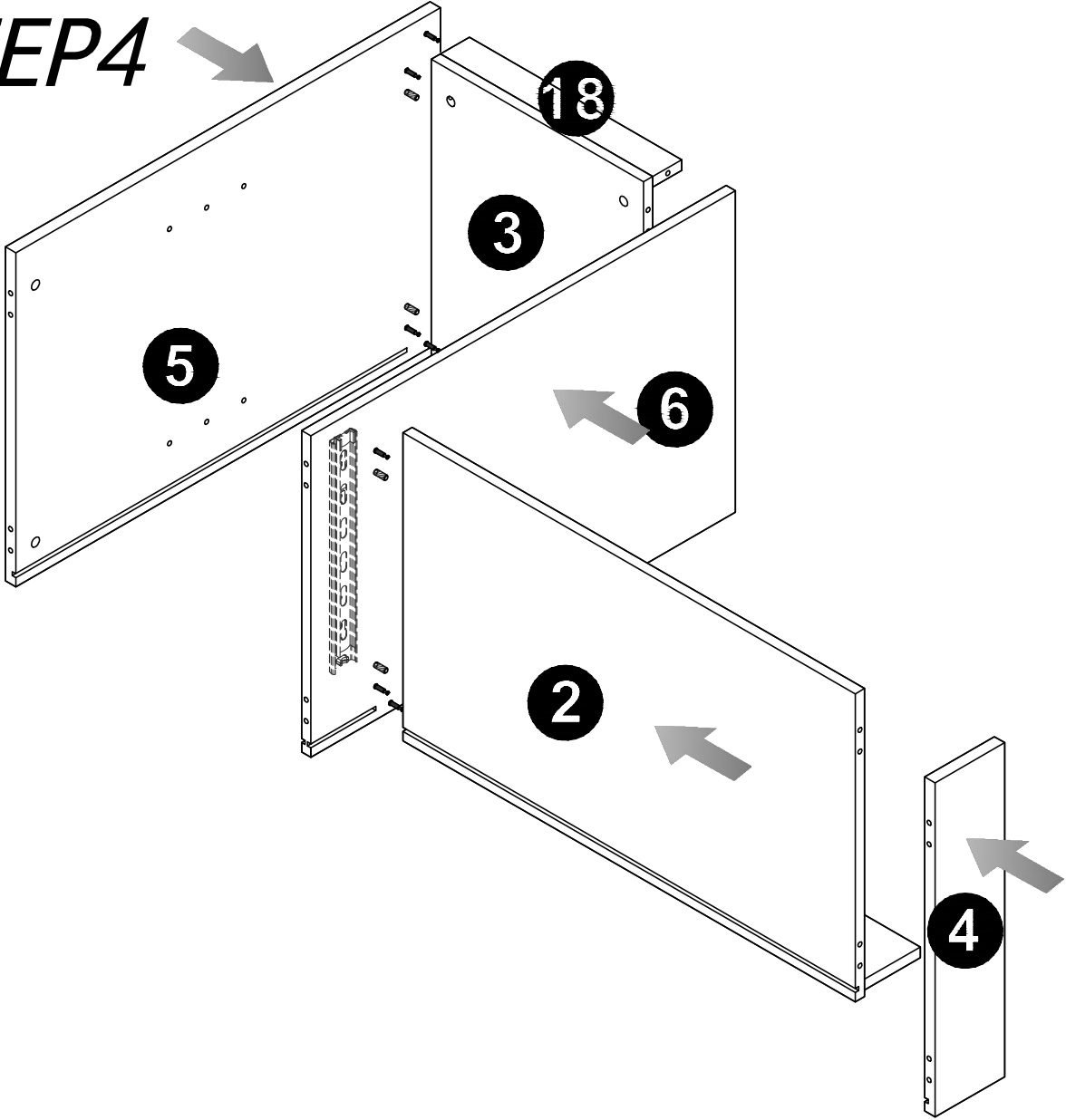

STEP 5

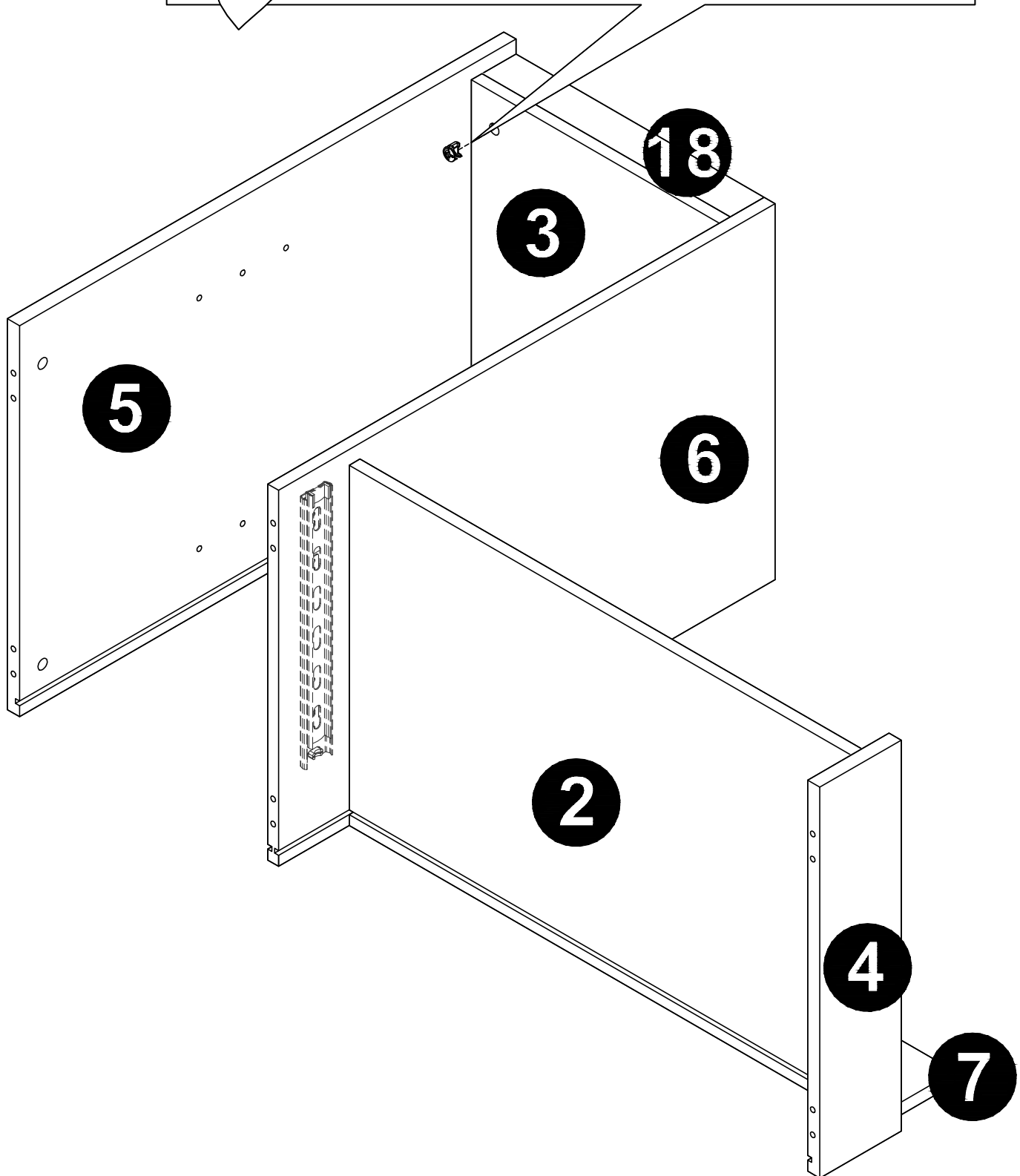
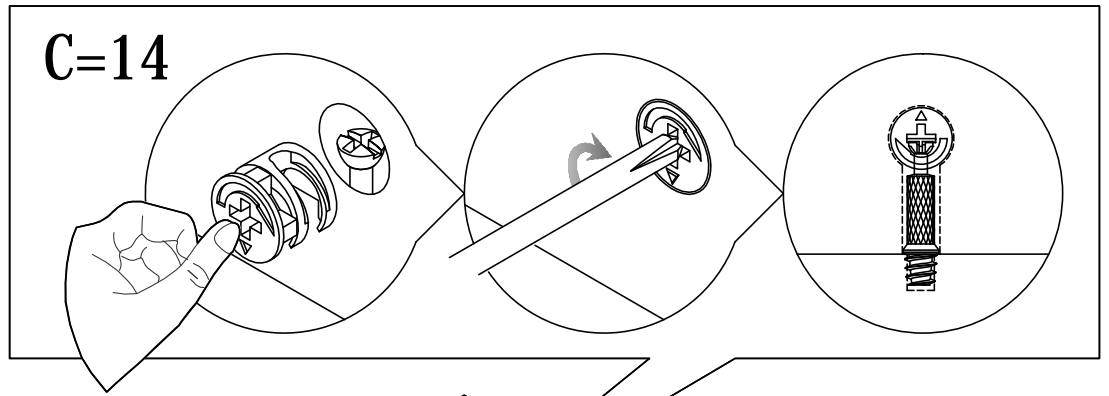

STEP 6

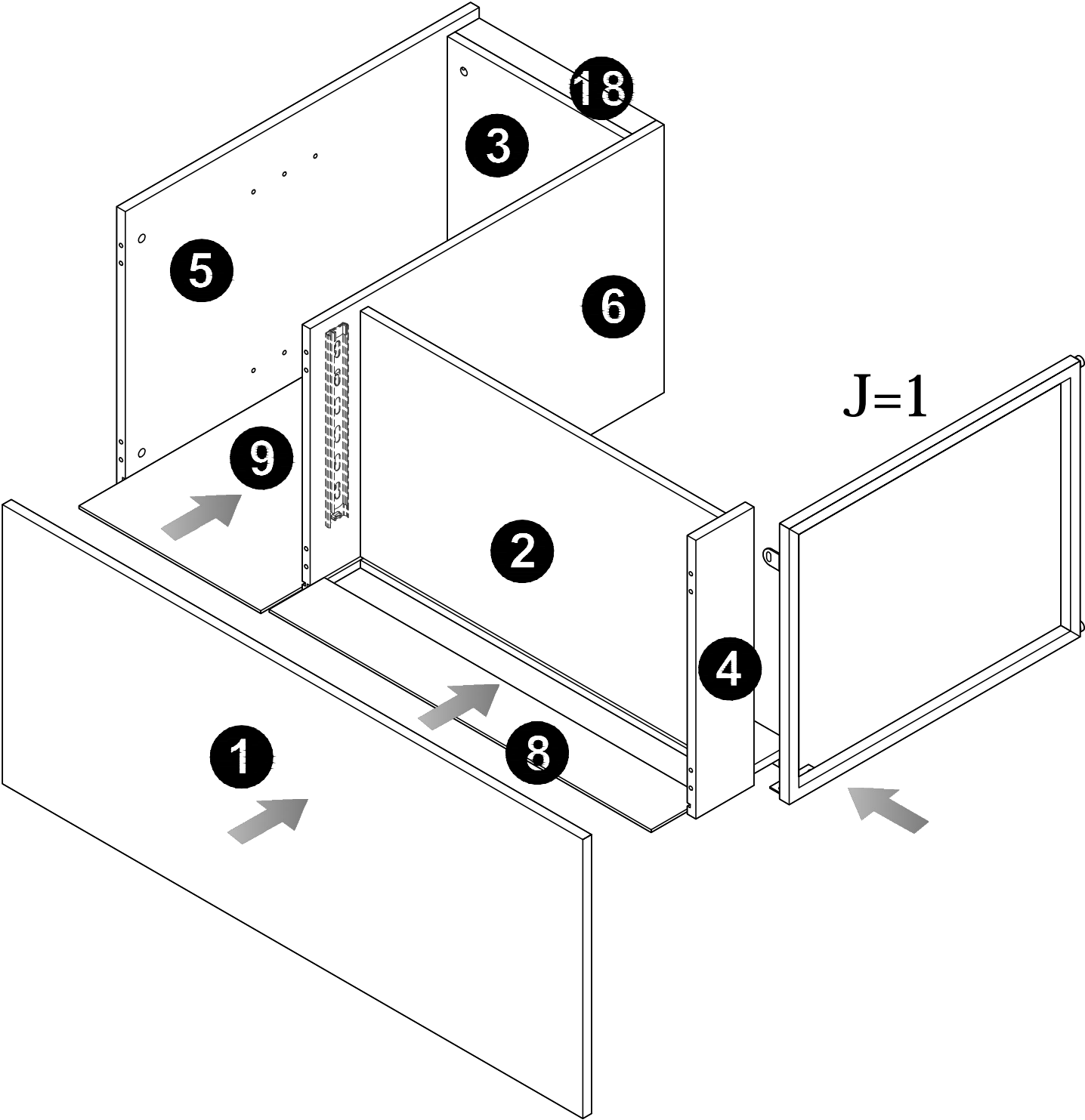

STEP 7

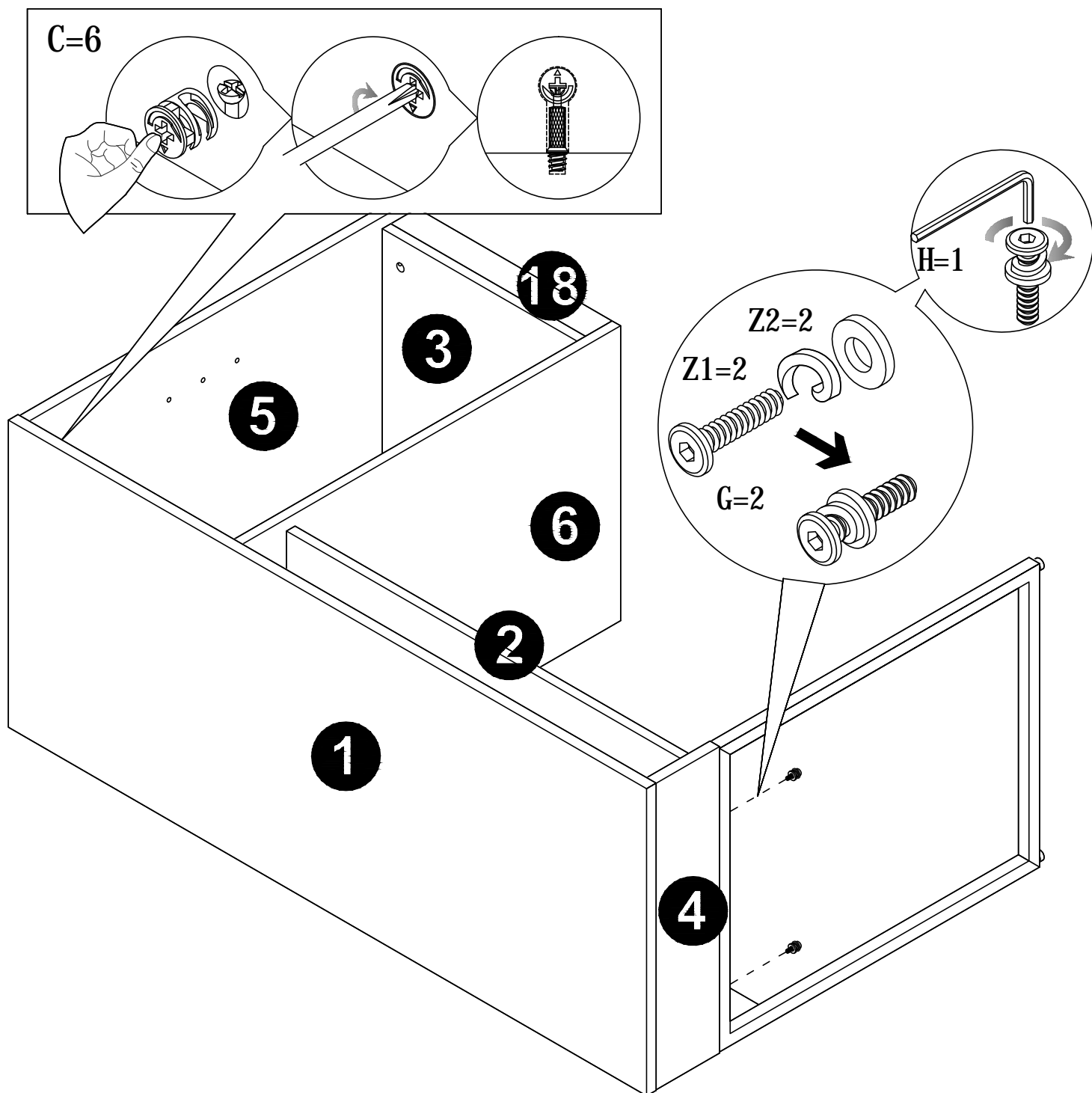

STEP 8

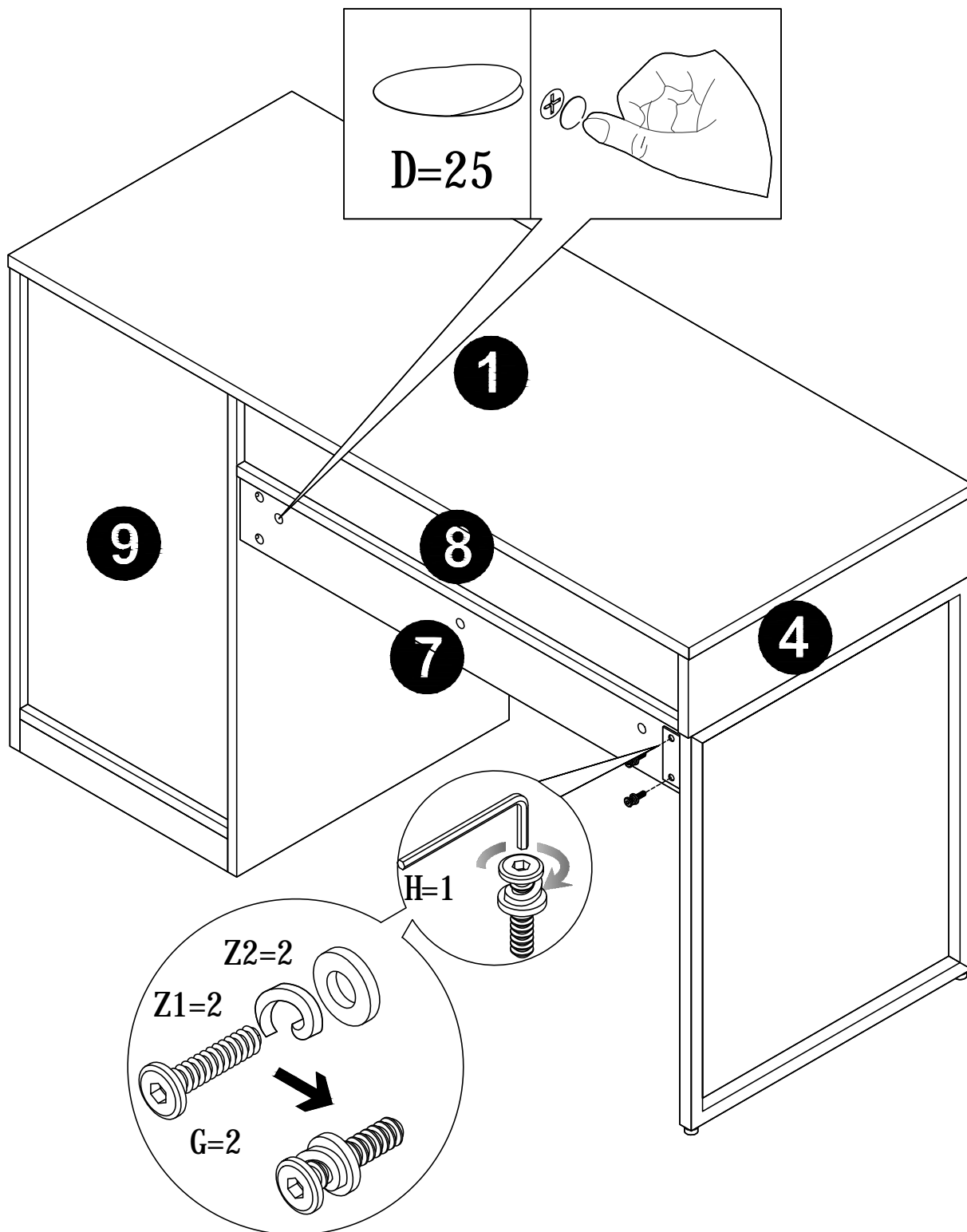

STEP 9

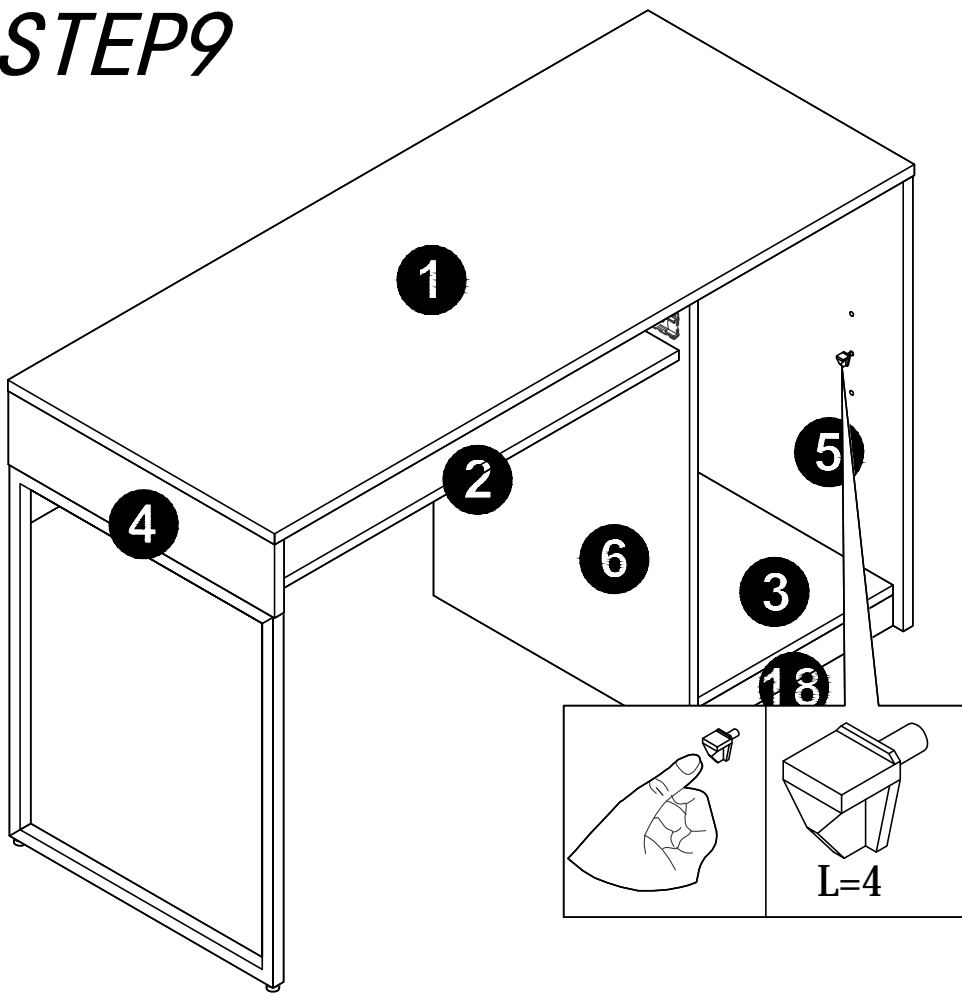

STEP 10

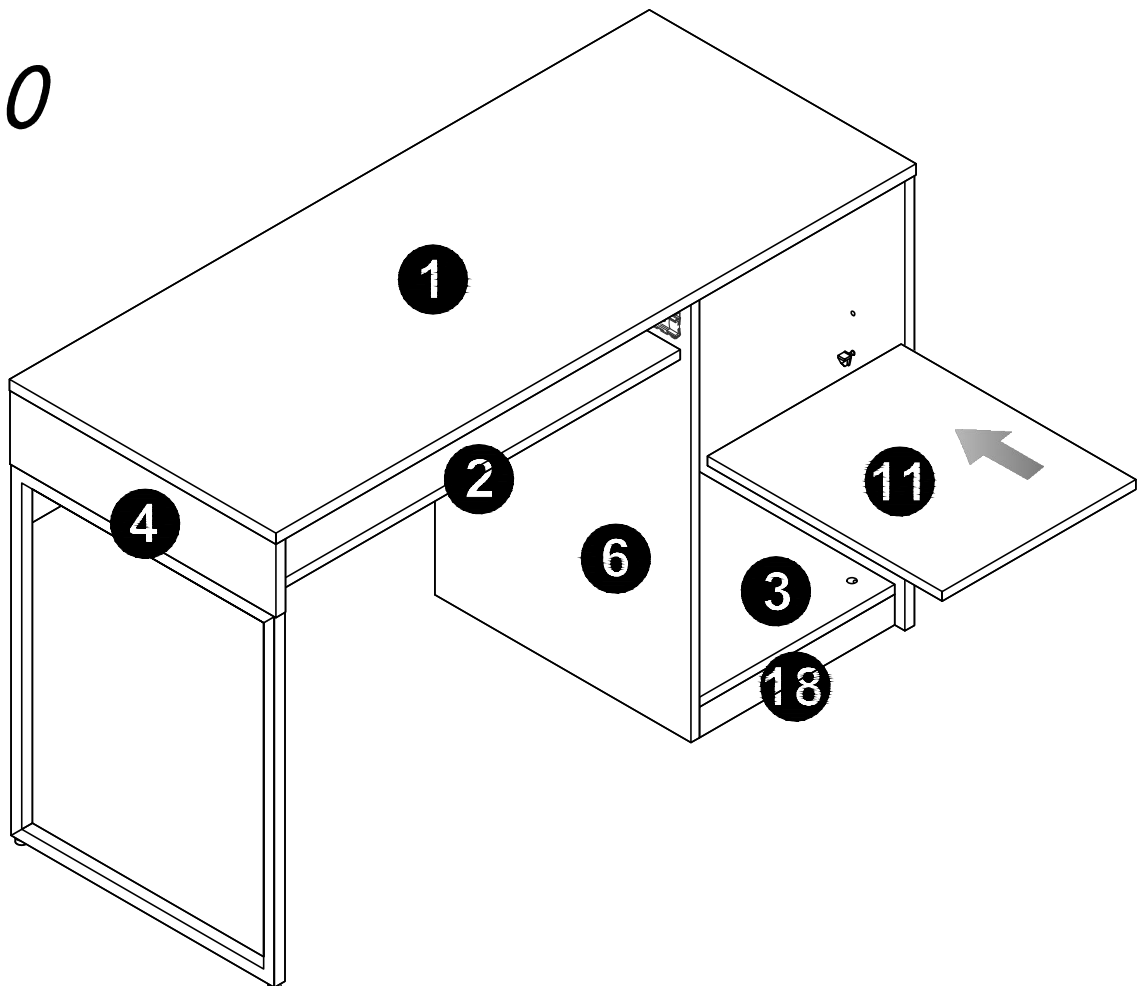

STEP 11

11-1

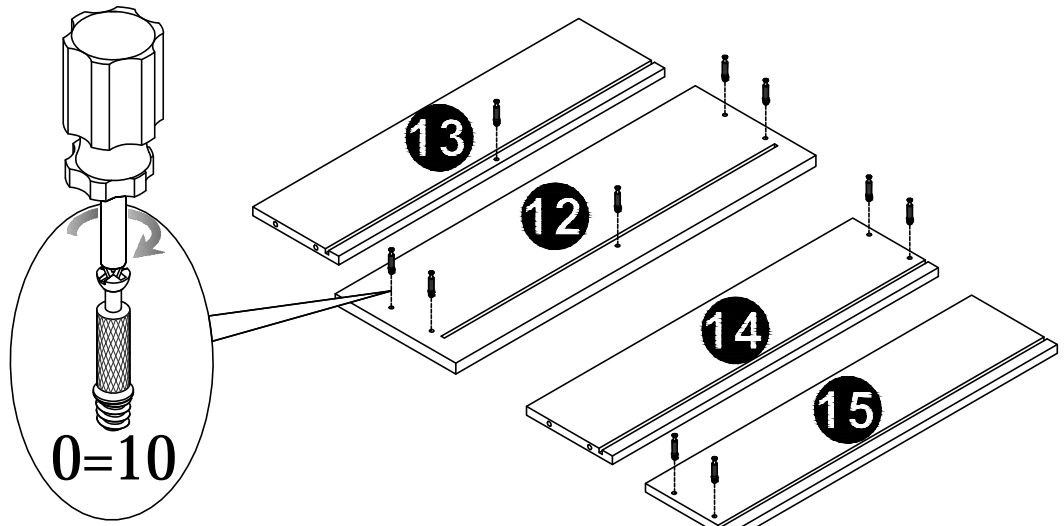

11-2

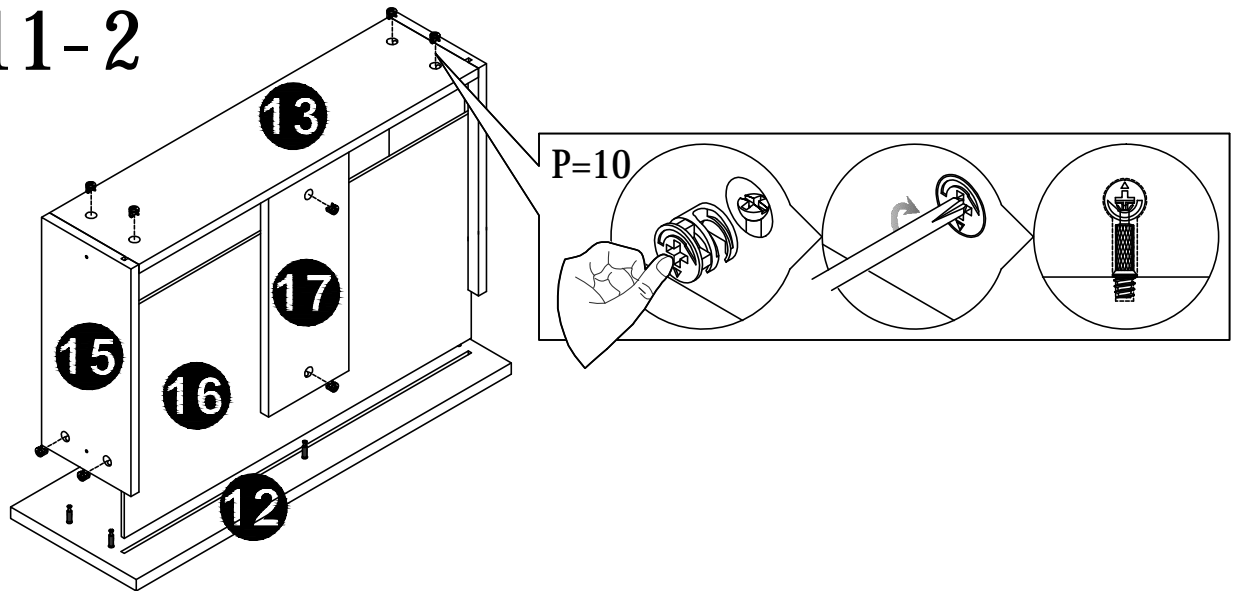

11-3

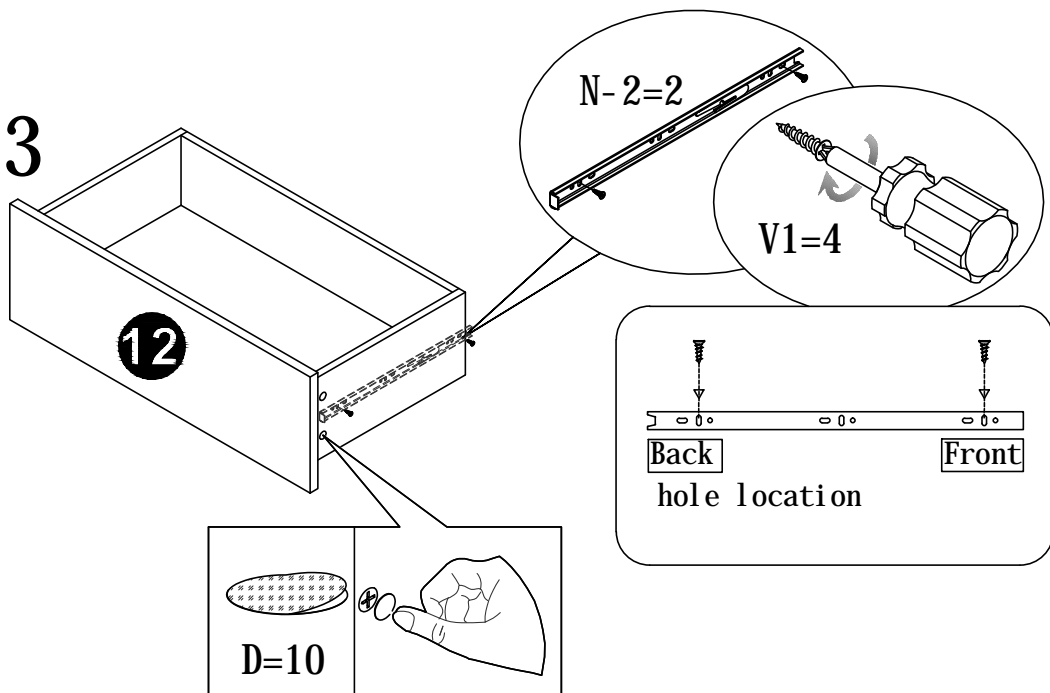

STEP 12

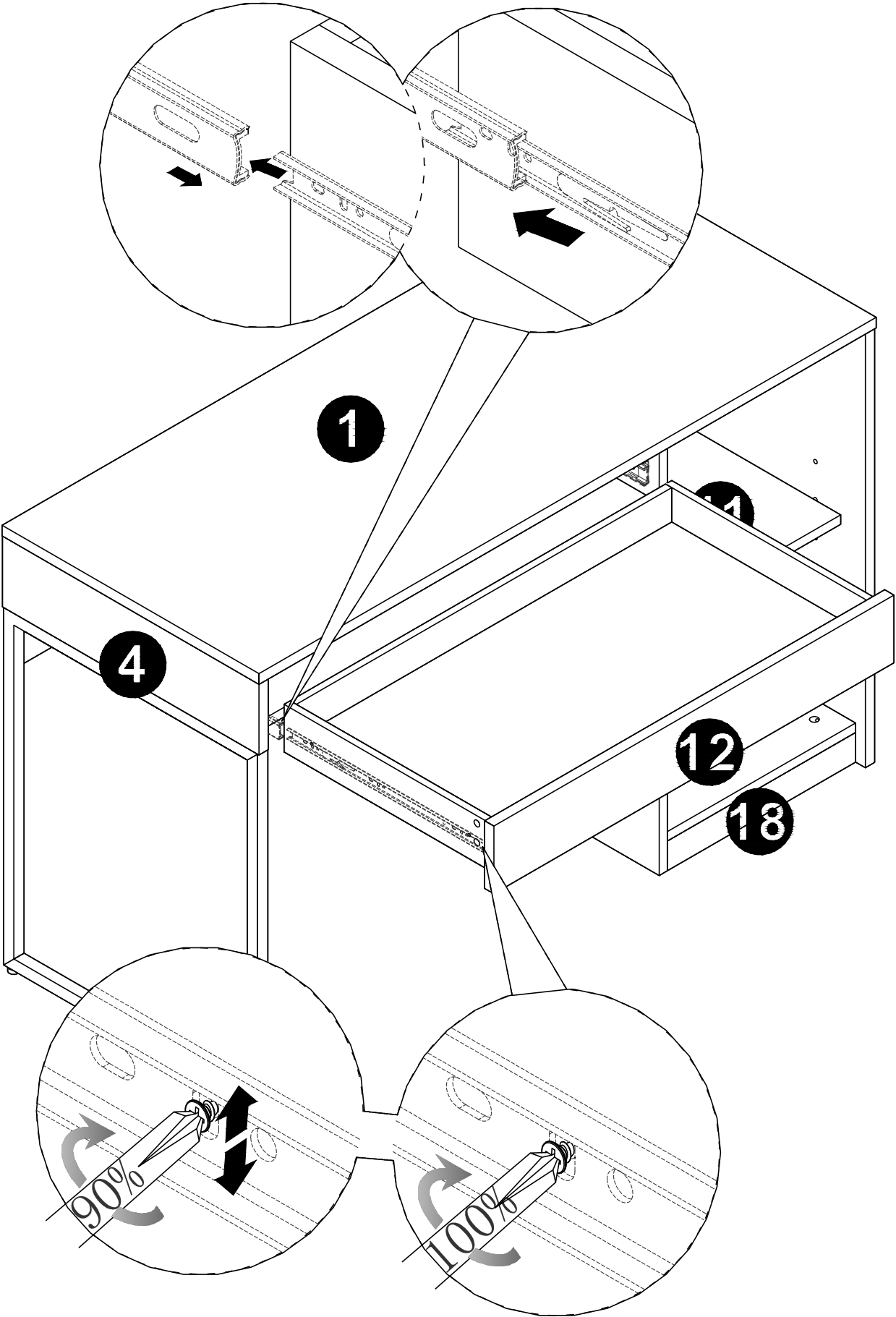

STEP 13

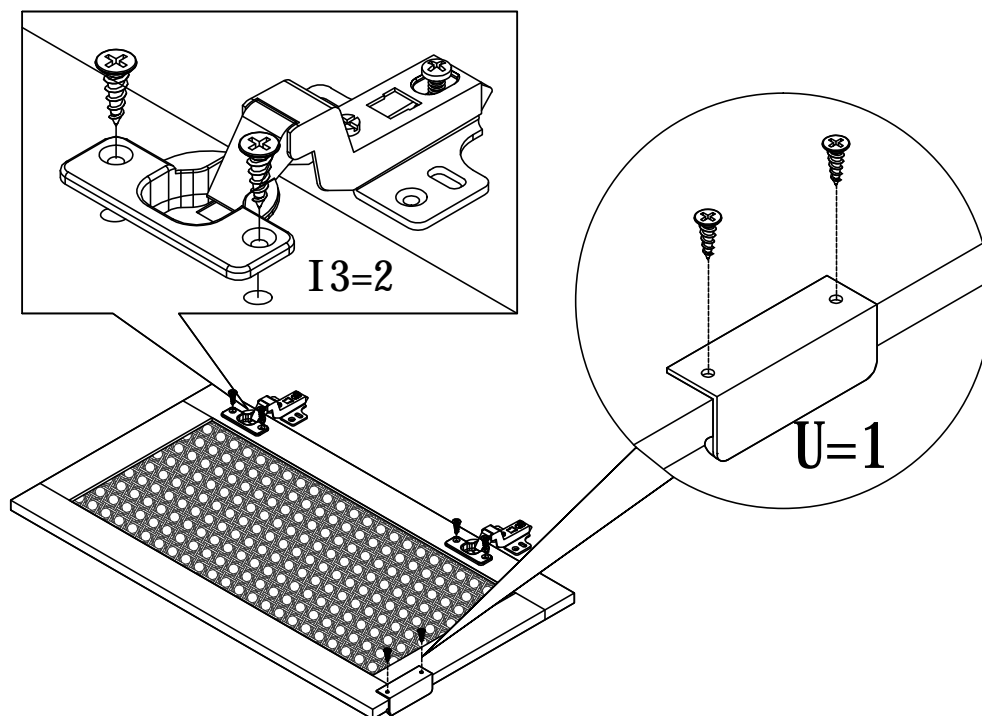

STEP 14

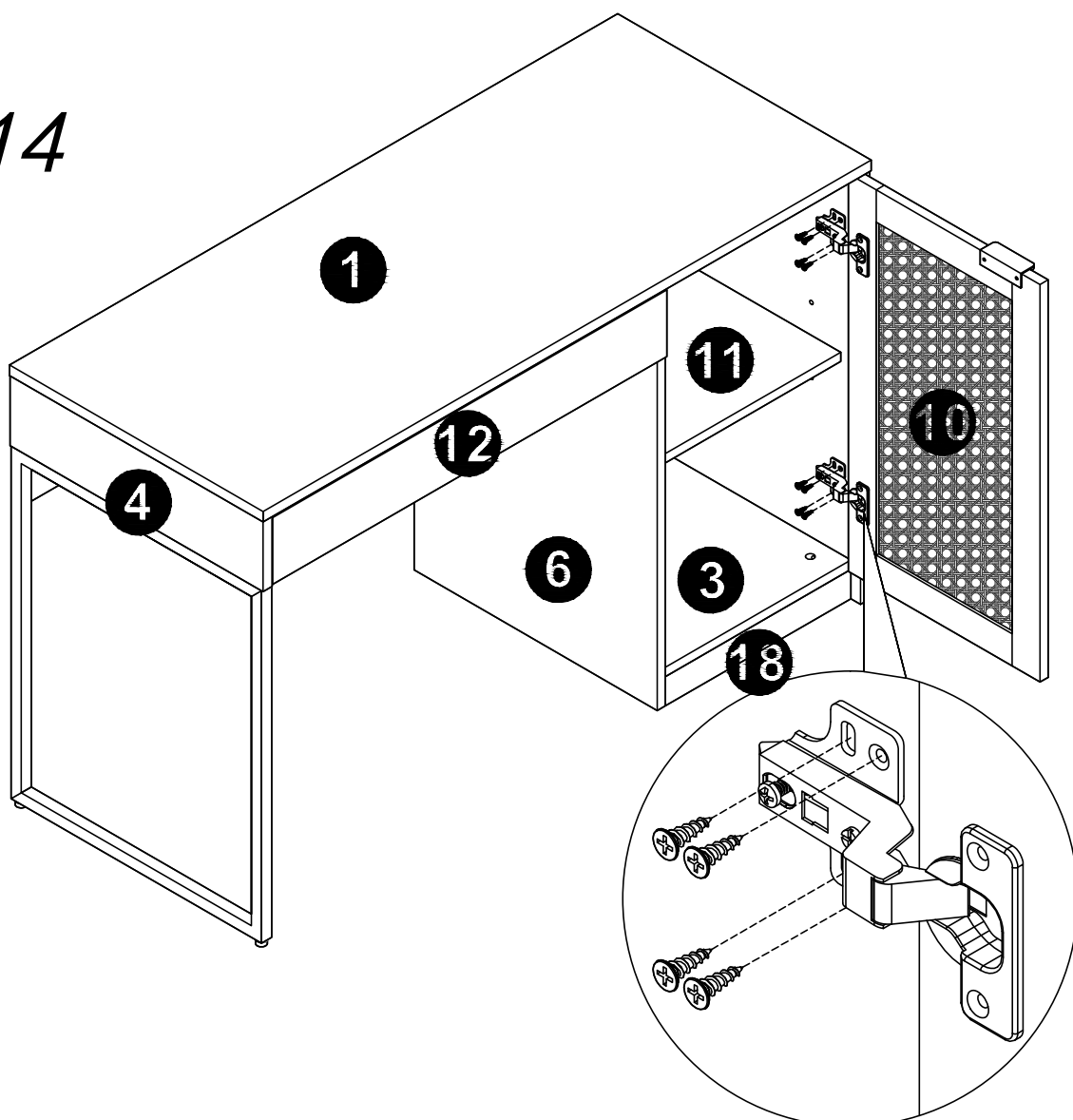

STEP 15

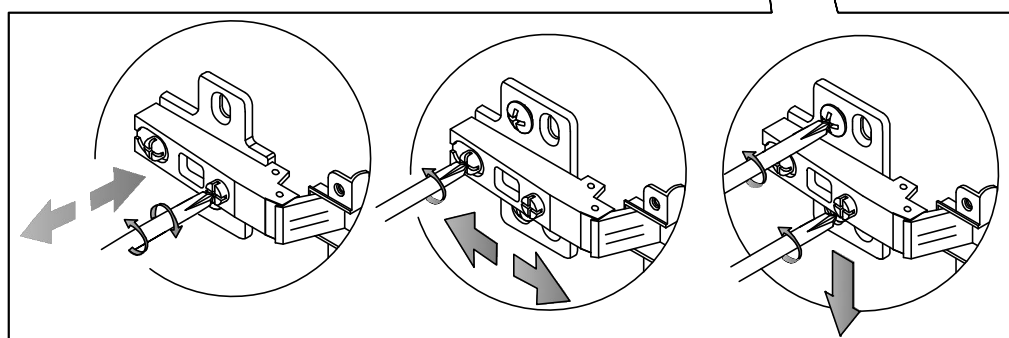
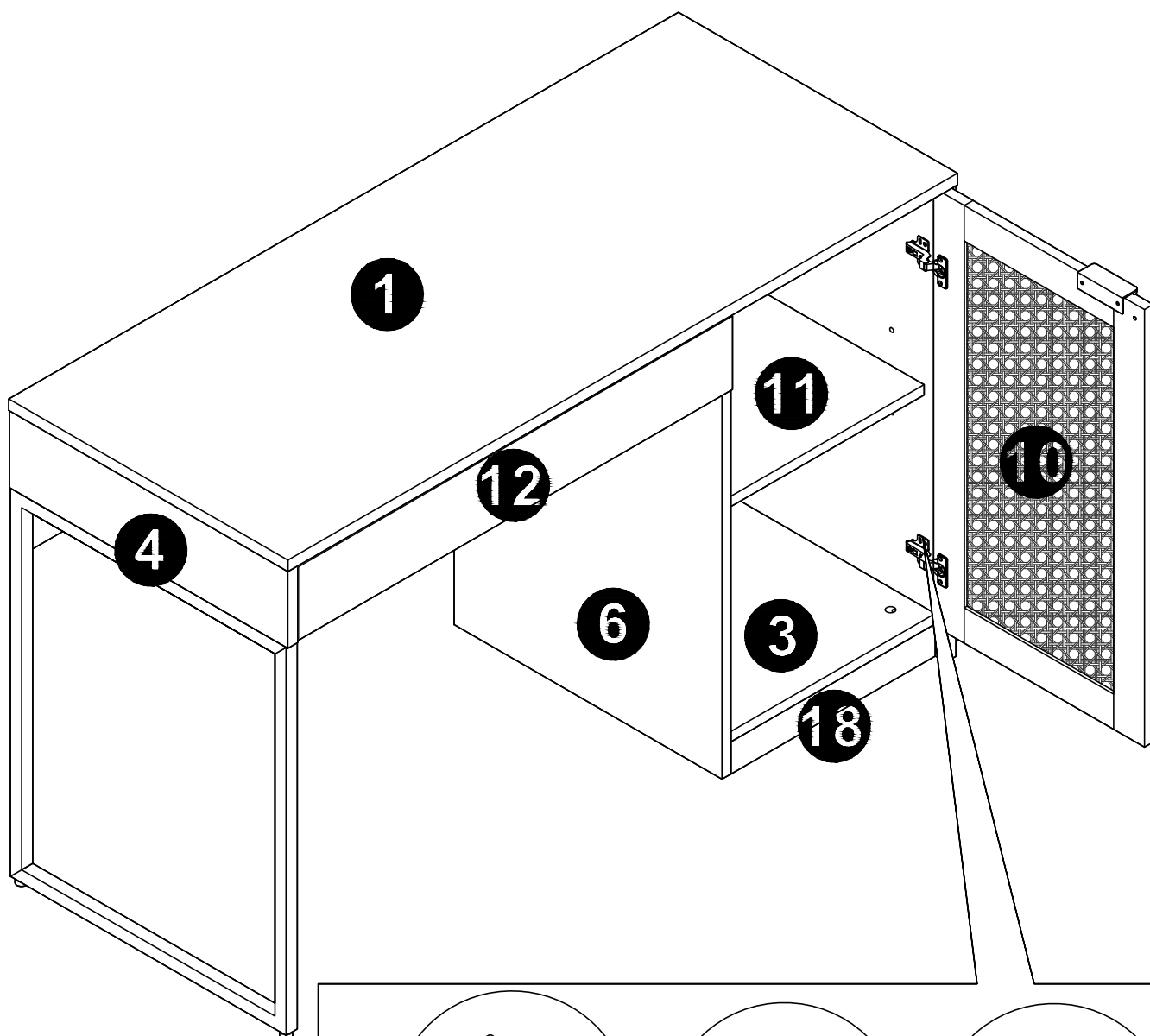

STEP 16

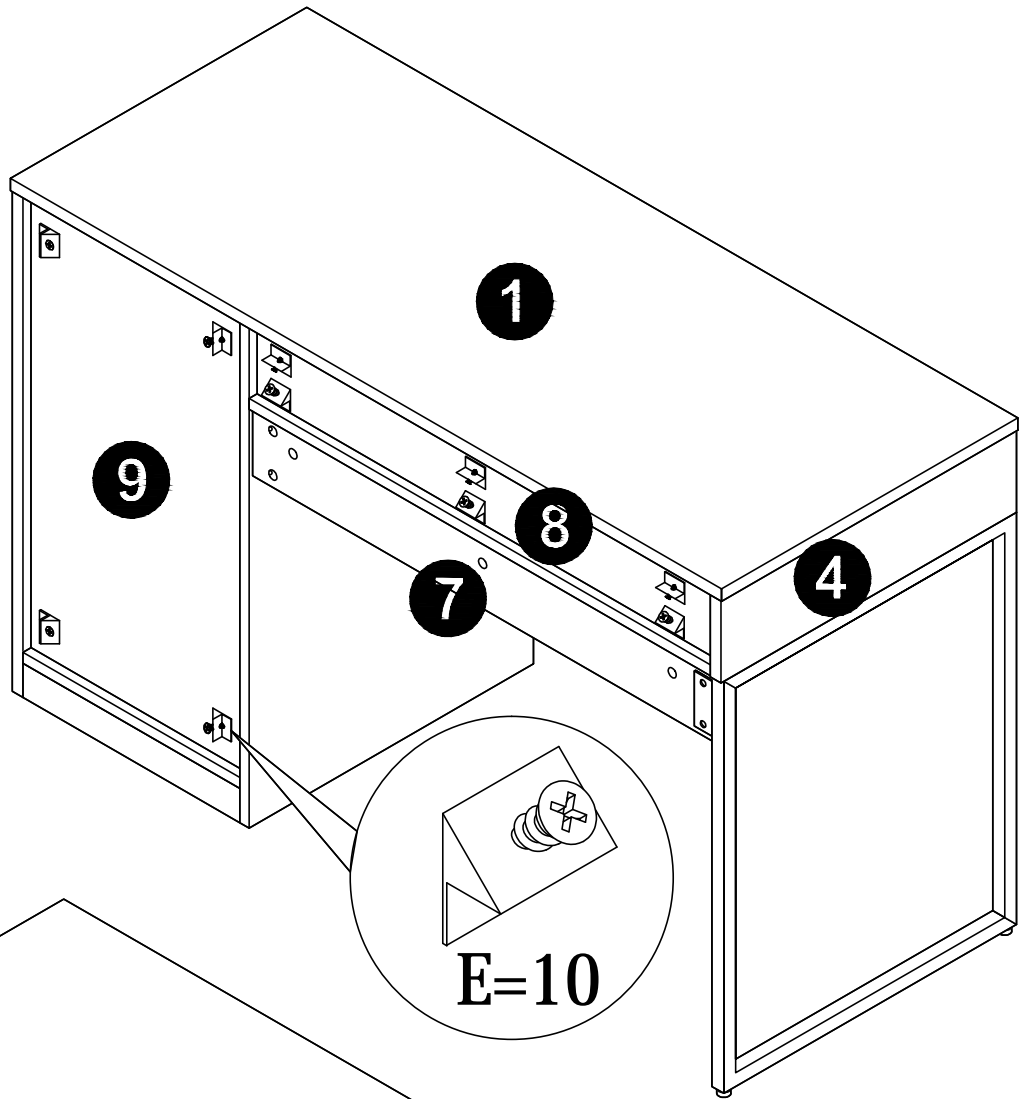

STEP 17

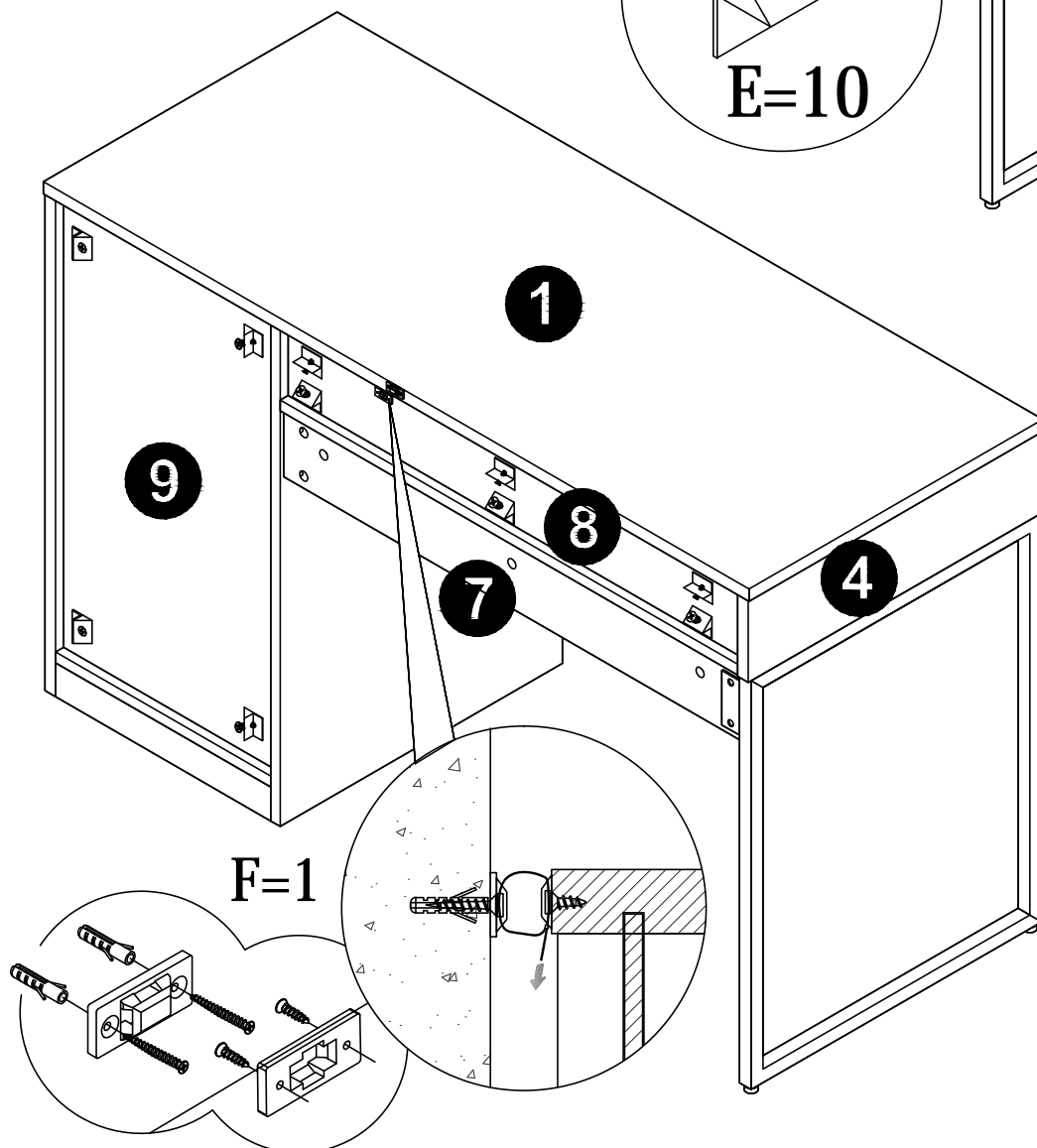

STEP18

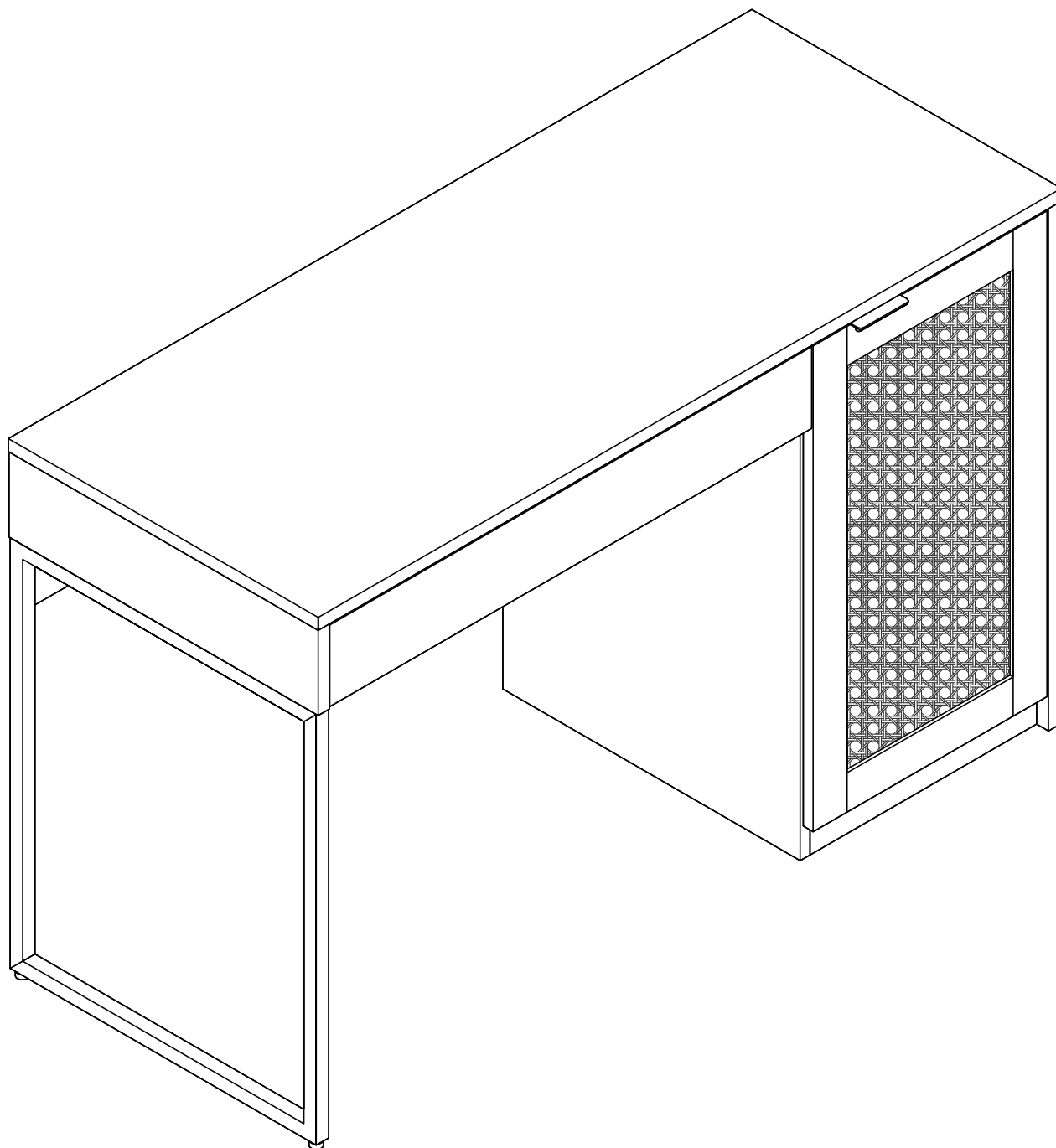

FINISH