

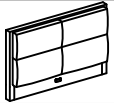

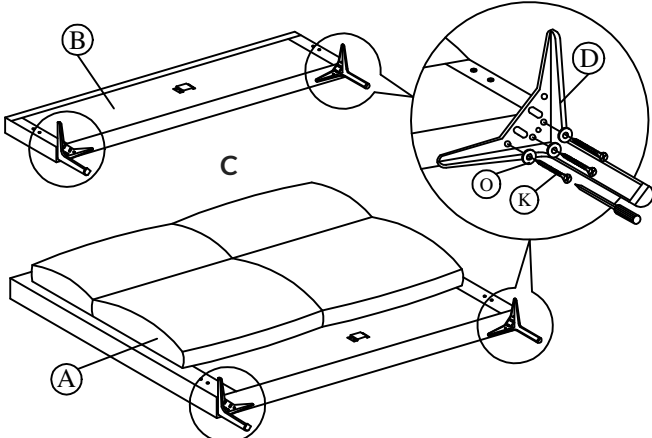

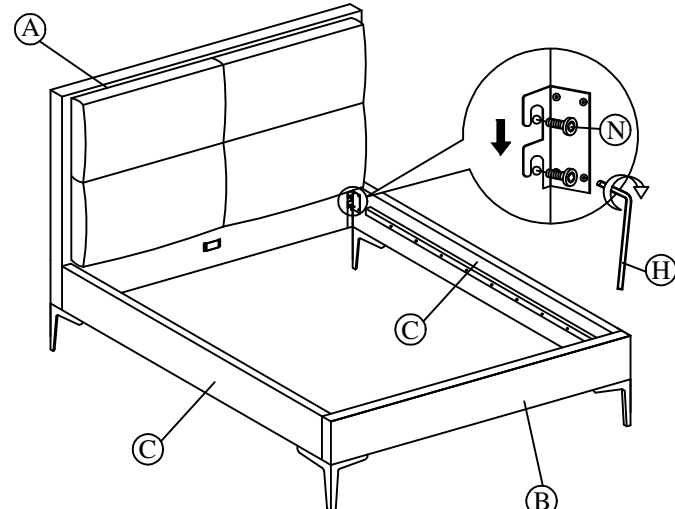









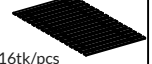

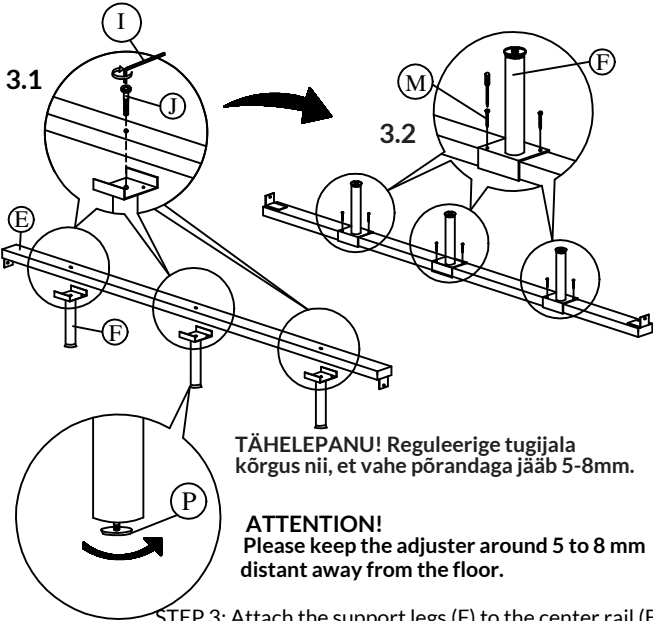
KOKKUPANEKUJUHEND / ASSEMBLY INSTRUCTION

LENA 28856, 28857

			SAMM 1: Kinnitage jalad (D) jalutsi (B) ja peatsi (A) külge.		SAMM 2: Kinnitage küljepaneel (C) jalutsi (B) ja peatsi (A) vahele.			
A		1						
B		1						
C		2						
D		4						
E		1						
F		3						
G		1					STEP 1: Install the legs (D) to footboard (B) and headboard (A).	
H		1	SAMM 3: Kinnitage tugijalad (F) keskmise tugitala (E) külge.		SAMM 4: Kinnitage keskmine tugitala (E) klambritesse peatsi (A) ja jalutsi (B) keskel. Kinnitage tugijalg kruvidega (F) peatsi ja jalutsi külge. Kruvikeeraja ei kuulu komplekti.			
I		1	 <p>TÄHELEPANU! Reguleerige tugijala kõrgus nii, et vahe põrandaga jääb 5-8mm.</p> <p>ATTENTION! Please keep the adjuster around 5 to 8 mm distant away from the floor.</p>		STEP 4: Slide the center rail (E) to the headboard (A) and footboard (B). Tighten screws (K) by screw driver (not included) to the headboard and footboard.			
J		3						
K		14						
L		35						
M		6						
N		8						
O		12						
P		3						
					STEP 3: Attach the support legs (F) to the center rail (E).		<p>ATTENTION! The support beam must be secured with a screw to hold the bed base firmly in place.</p> <p>TÄHELEPANU! Tugitala peab olema kindlasti kruviga kinnitatud, et voodipõhi püsiks kindlalt paigal.</p>	

SAMM 5: Kinnitage põhjalipid (G) kruvidega küljepaneelide ja keskmise tugitala (E) külge. Keerake nurgaklambrite poldid lõuni kinni.

STEP 5: Affix the Slat (G) to the side rail support wood and the center rail (E). Tighten all the 4 corner .

