

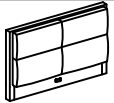

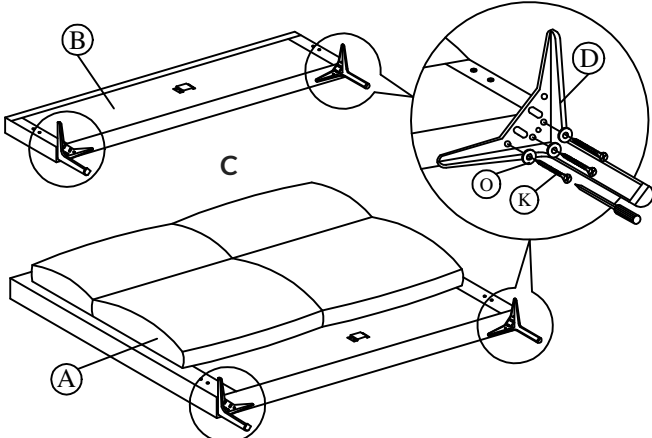

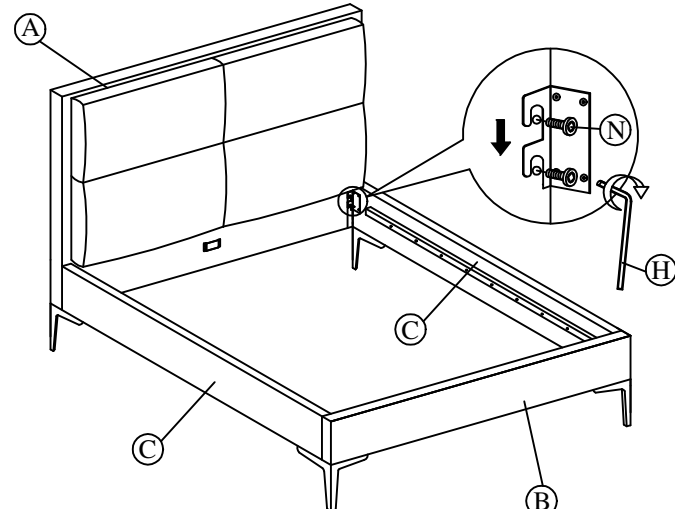









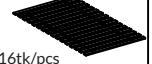

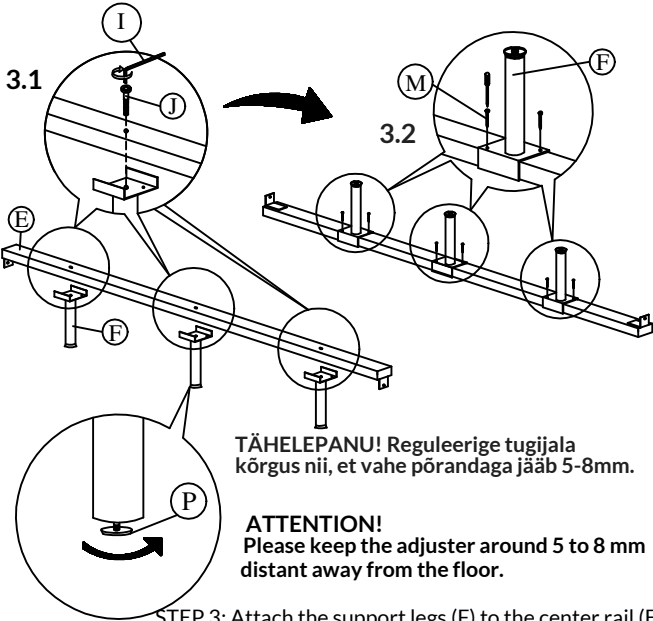
# KOKKUPANEKUJUHEND / ASSEMBLY INSTRUCTION

## LENA 28856, 28857

			SAMM 1: Kinnitage jalad (D) jalutsi (B) ja peatsi (A) külge.	SAMM 2: Kinnitage küljepaneel (C) jalutsi (B) ja peatsi (A) vahele.
A		1	 <p>STEP 1: Install the legs (D) to footboard (B) and headboard (A).</p>	 <p>STEP 2: Attach side rail (C) to footboard (B) and headboard (A).</p>
B		1		
C		2		
D		4		
E		1		
F	 215mm	3		
G	 16tk/pcs	1		
H	 M5x70mm	1	 <p>STEP 3: Attach the support legs (F) to the center rail (E).</p> <p>TÄHELEPANU! Reguleerige tugijala kõrgus nii, et vahe põrandaga jääb 5-8mm.</p> <p>ATTENTION! Please keep the adjuster around 5 to 8 mm distant away from the floor.</p>	
I	 M4x65mm	1		
J	 JCBC M6x40mm	3		
K	 CSK M4x25mm	14		
L	 CSK M4x32mm	35		
M	 CSK M4x16mm	6		
N	 JCBB M8x20mm	8		
O		12		
P		3		
				SAMM 3: Kinnitage tugijalad (F) keskmise tugitala (E) külge.
			 <p>STEP 4: Slide the center rail (E) to the headboard (A) and footboard (B). Tighten screws (K) by screw driver (not included) to the headboard and footboard.</p> <p>ATTENTION! The support beam must be secured with a screw to hold the bed base firmly in place.</p> <p>TÄHELEPANU! Tugitala peab olema kindlasti kruviga kinnitatud, et voodipõhi püsiks kindlalt paigal.</p>	

SAMM 5: Kinnitage põhjalipid (G) kruvidega küljepaneelide ja keskmise tugitala (E) külge. Keerake nurgaklambrite poldid lõuni kinni.

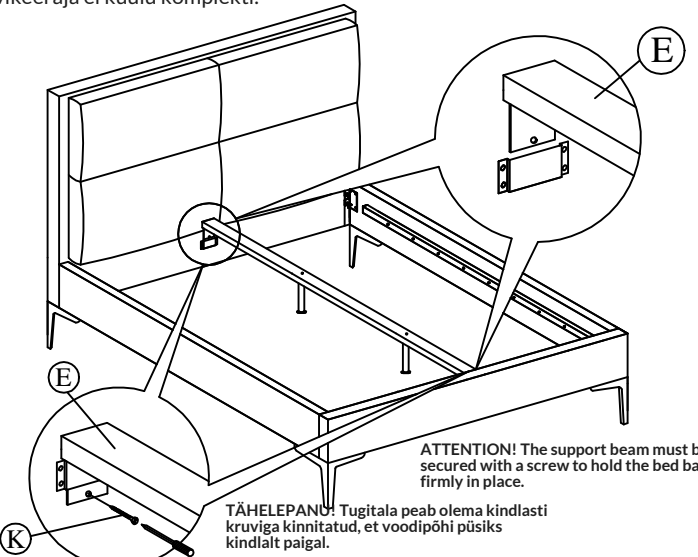
STEP 5: Affix the Slat (G) to the side rail support wood and the center rail (E). Tighten all the 4 corner .

