

# Assembly Instructions

2518

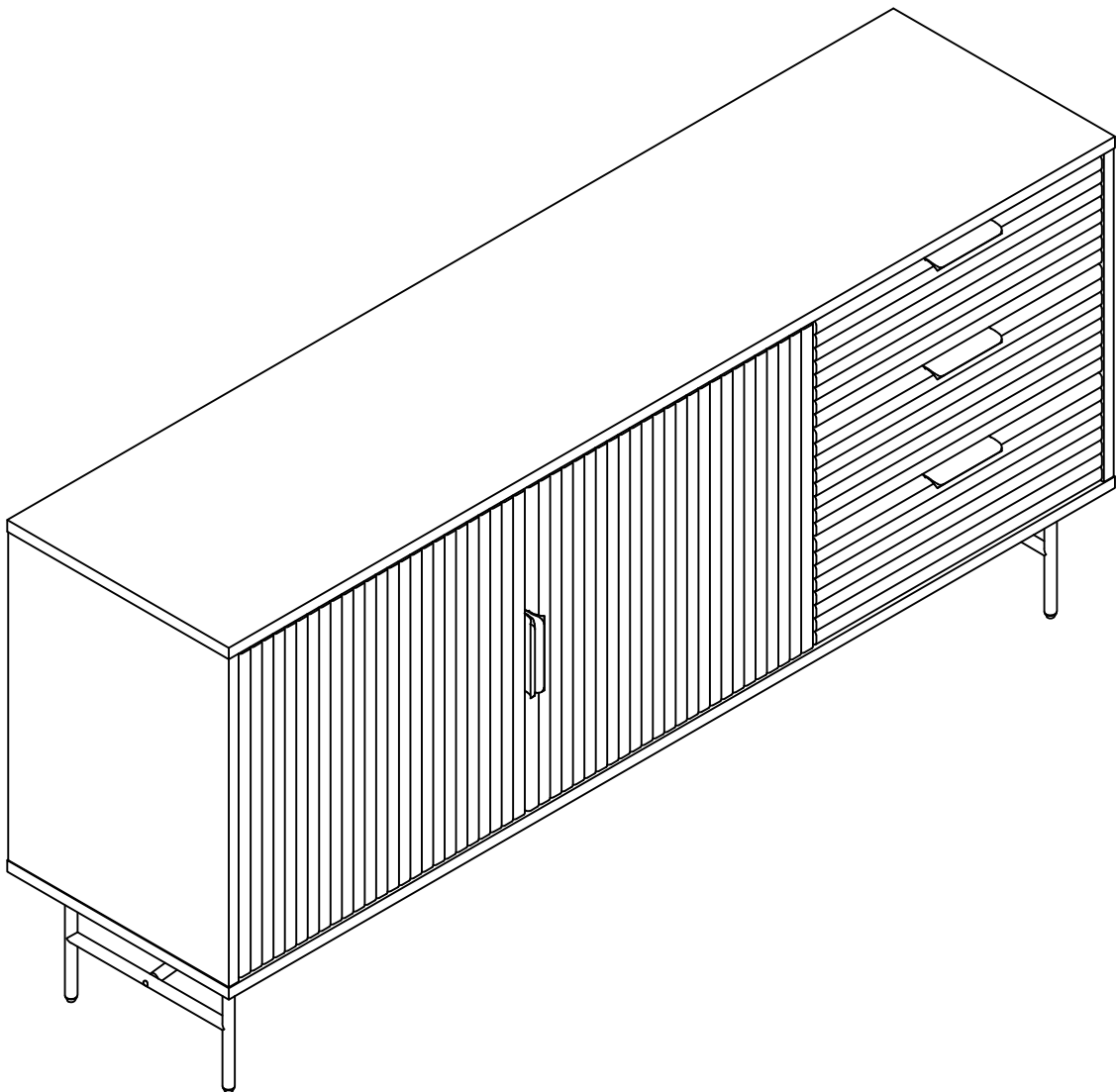

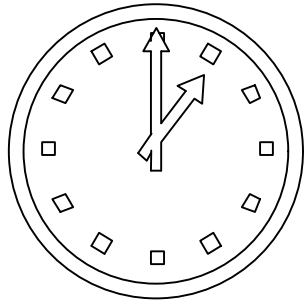

60 min

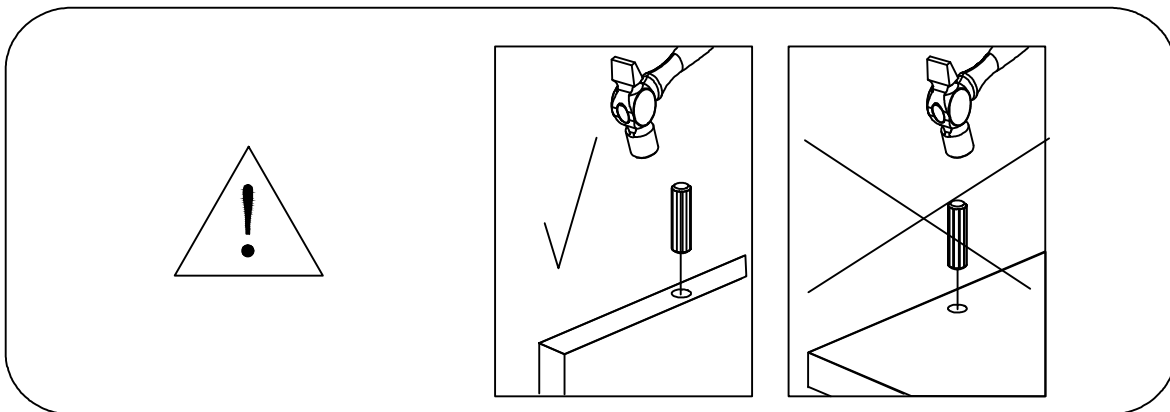
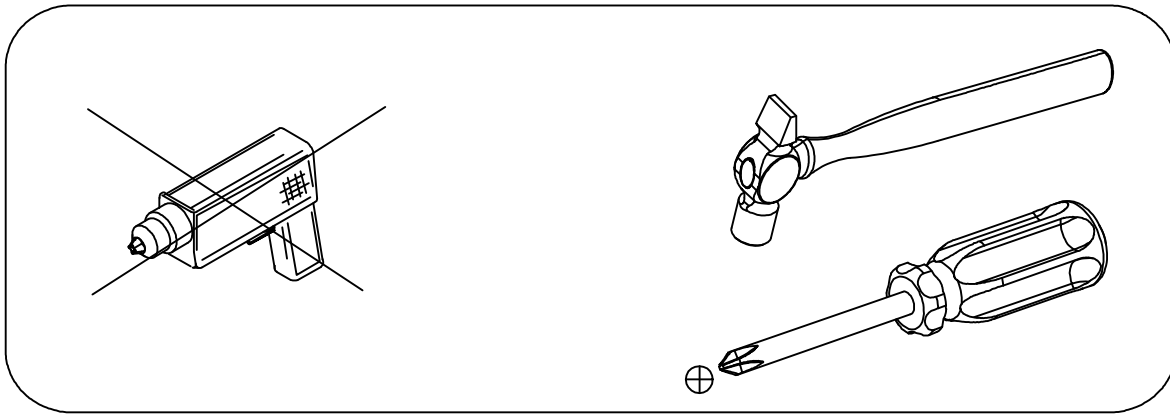
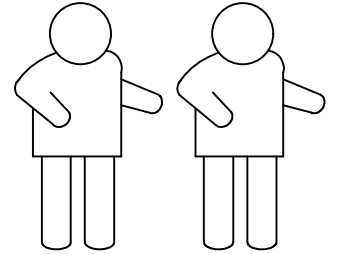
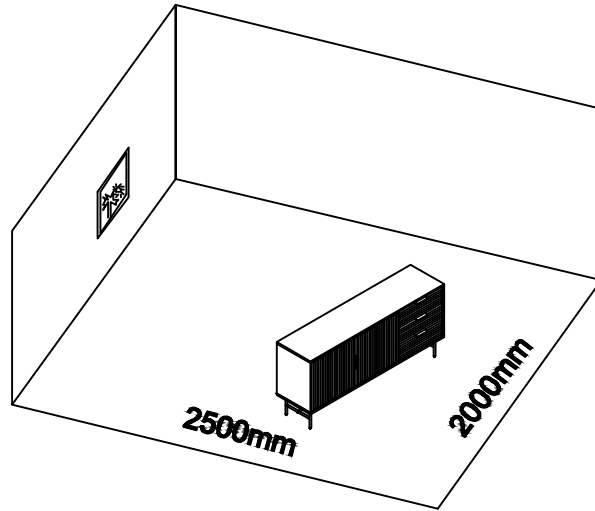

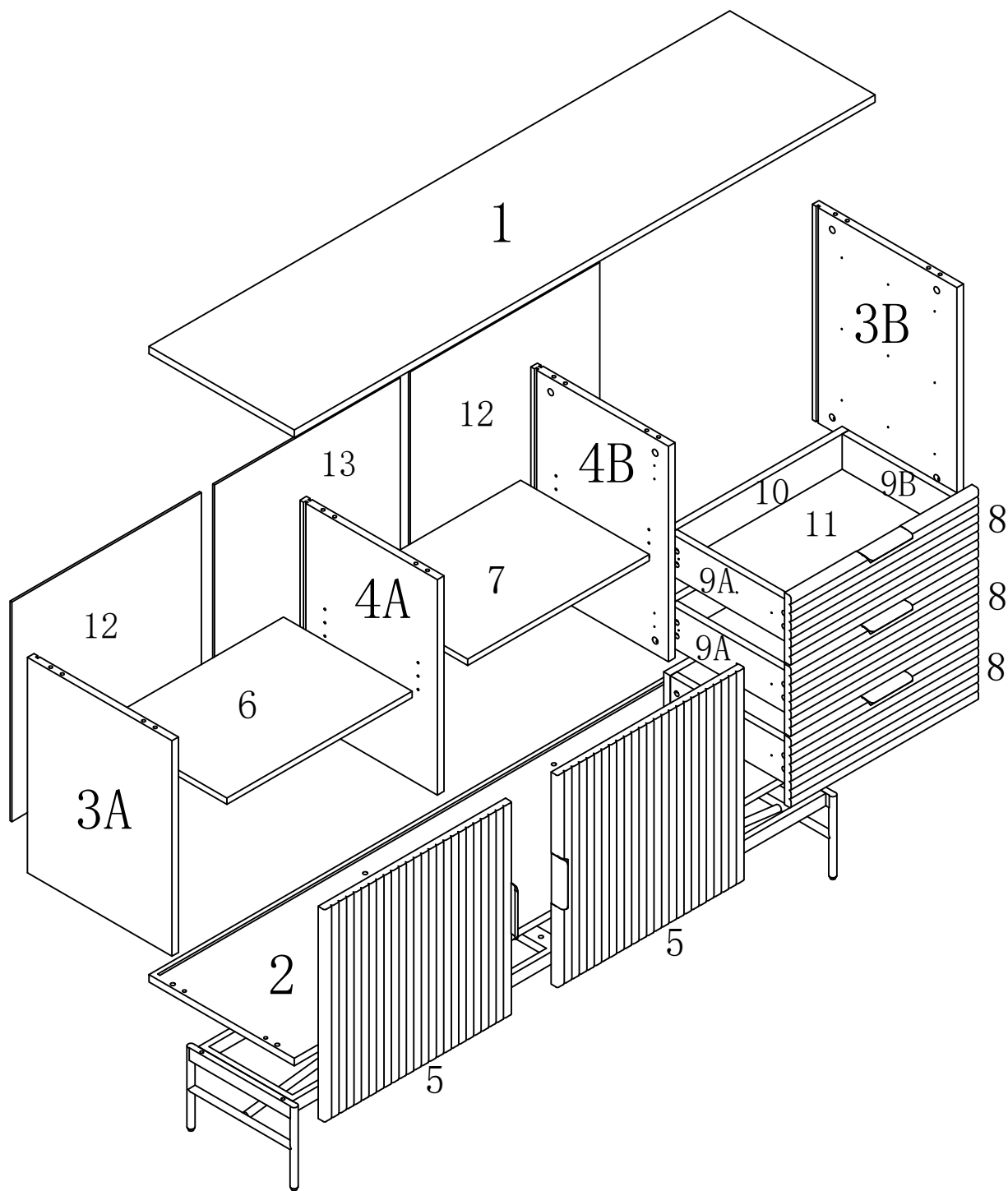



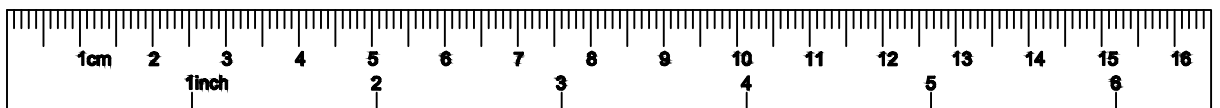









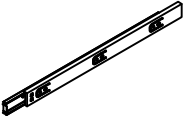

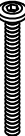

		2518
1	1	1600*400*18MM
2	1	1600*400*18MM
3A	1	514*398*18MM
3B	1	514*398*18MM
4A	1	514*379*18MM
4B	1	514*379*18MM
5	2	516*506*18MM
6	1	510*354*15MM
7	1	500*354*15MM
8	3	516*166*18MM
9A	3	332*100*18MM
9B	3	332*100*18MM
10	3	491*100*18MM
11	3	465*342*5MM
12	2	524*522*5MM
13	1	524*512*5MM

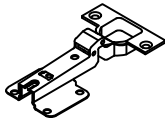

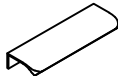
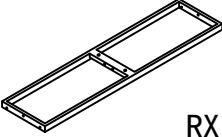
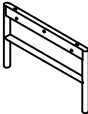
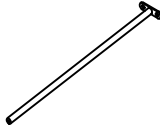

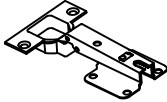
 φ 15*12 AX16	 M6*35 BX16	 φ 8*40 CX16	 M3.5*15 DX82
 M6*15 EX4	 M6*30 FX8	 M6*35 GX2	 350MM HX6
 φ 12*12 IX24	 M6*24 JX24	 M6*45 KX4	 LX18
 MX1	 NX12	 OX2	 PX4
 QX5	 RX1	 SX2	 TX2
 UX8	 VX2		

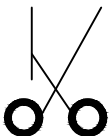
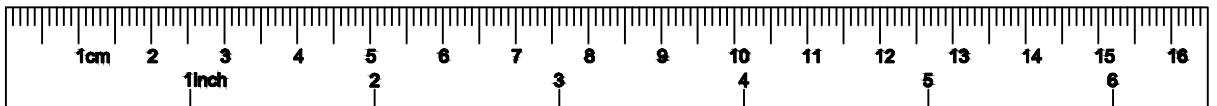

# 1



$$H=H1+H2$$

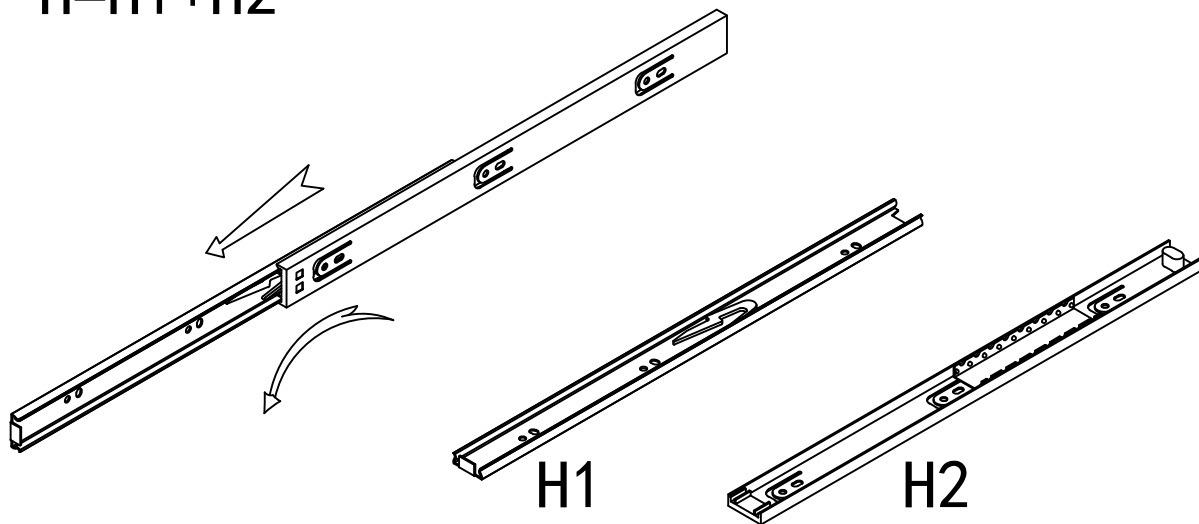

# 2

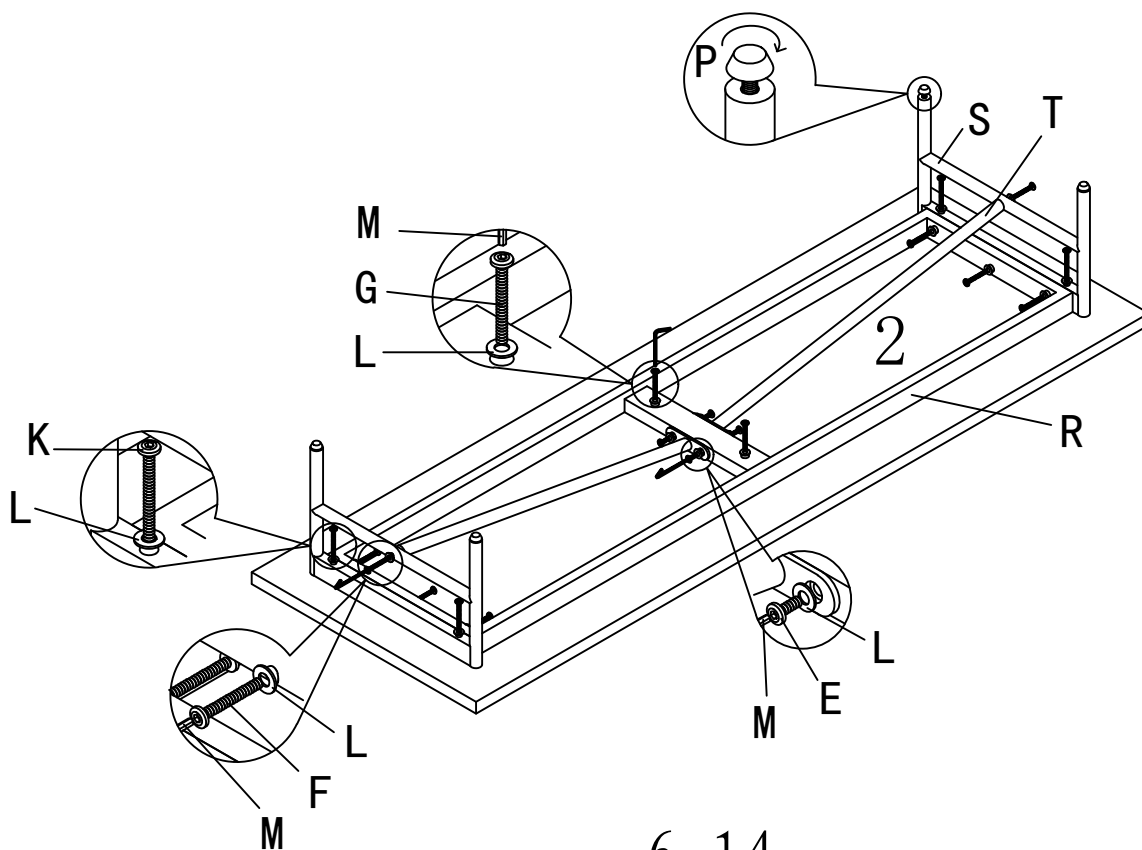
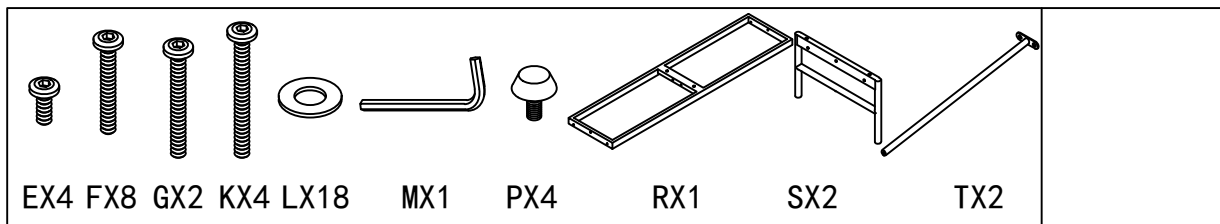

# 3

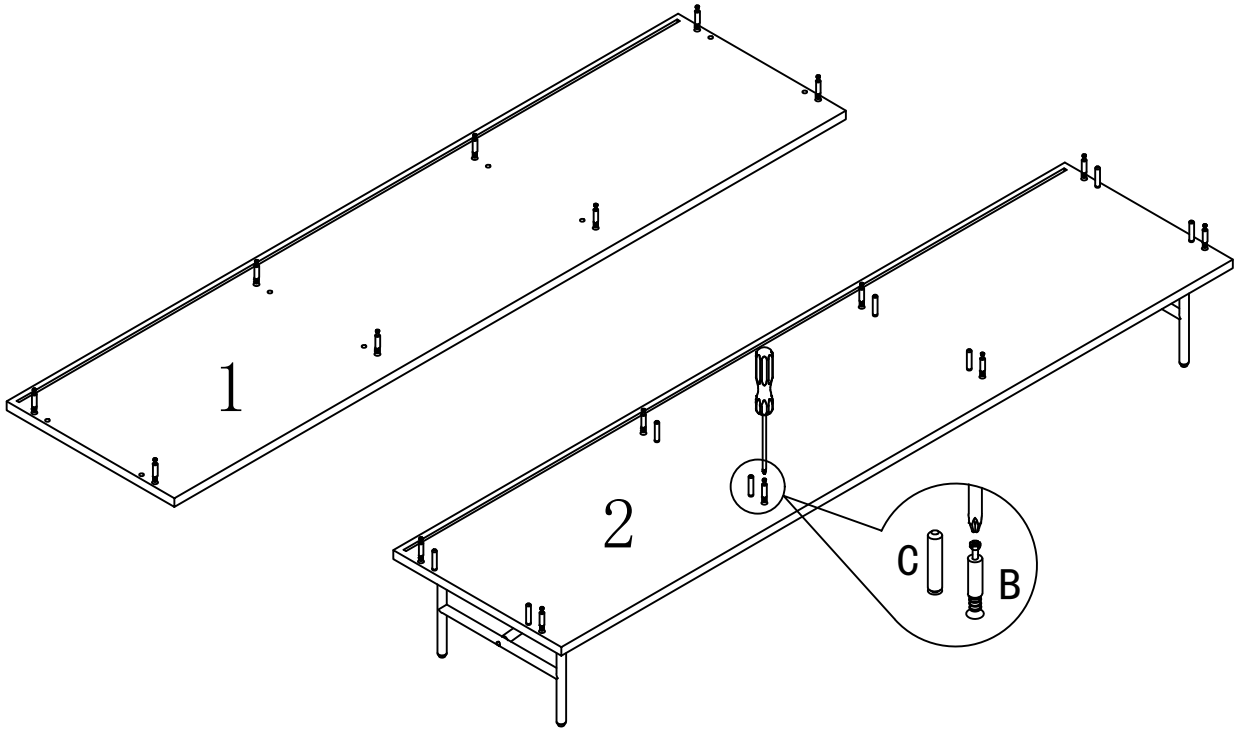
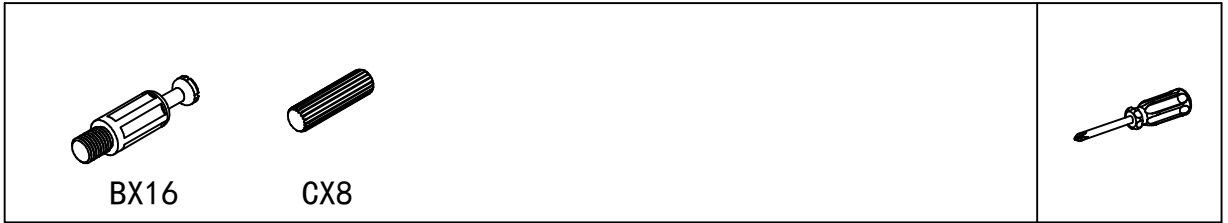

# 4

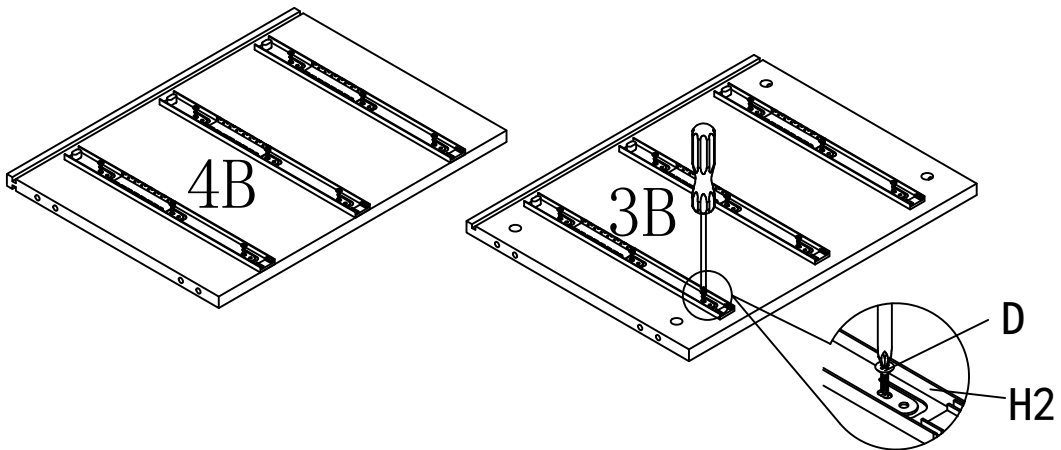
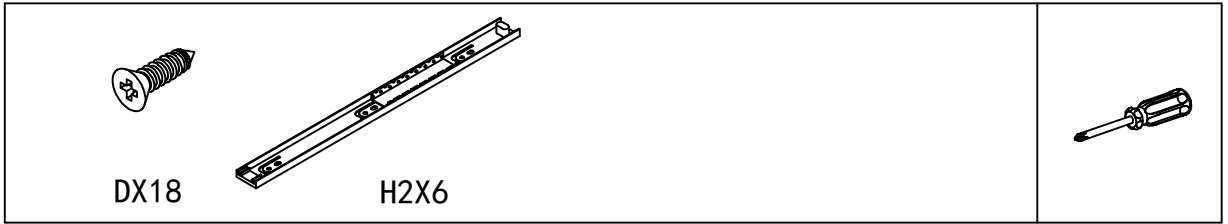

# 5

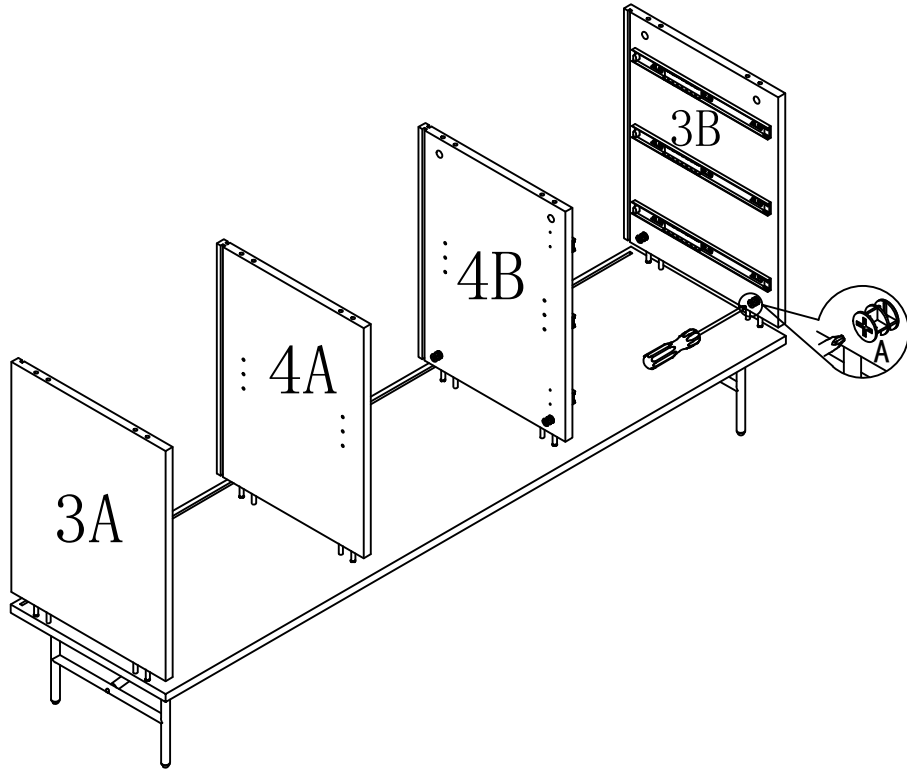
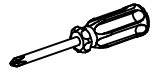
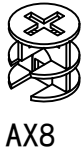

# 6

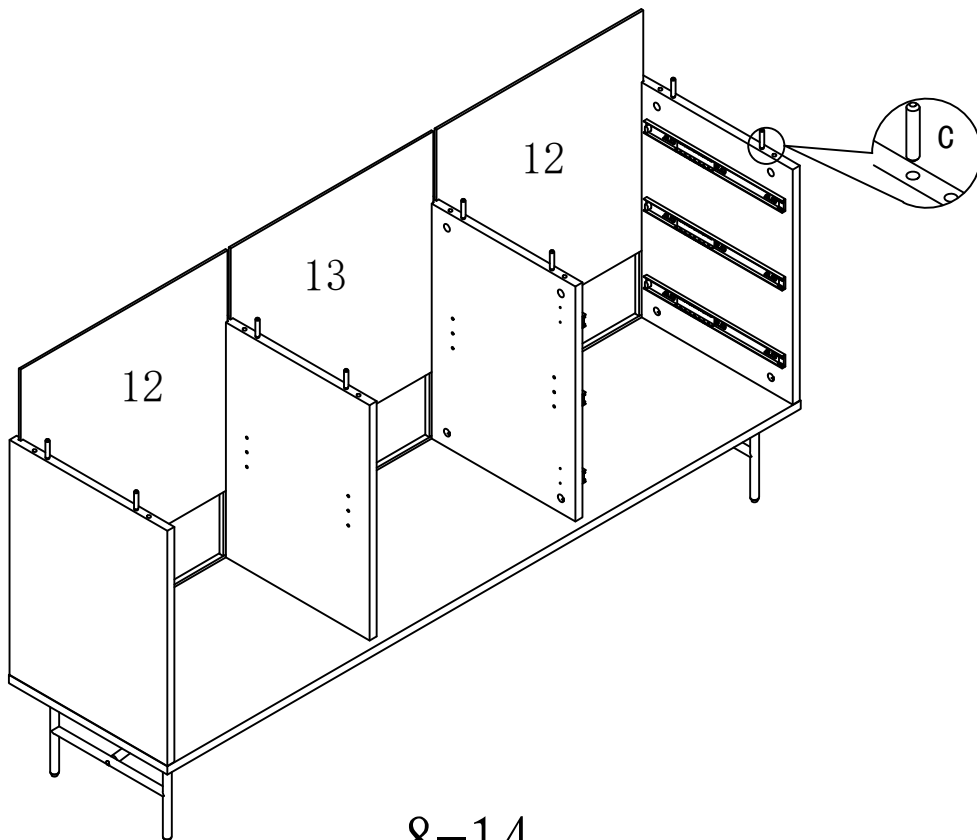
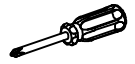



# 7

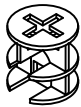

AX8



UX8

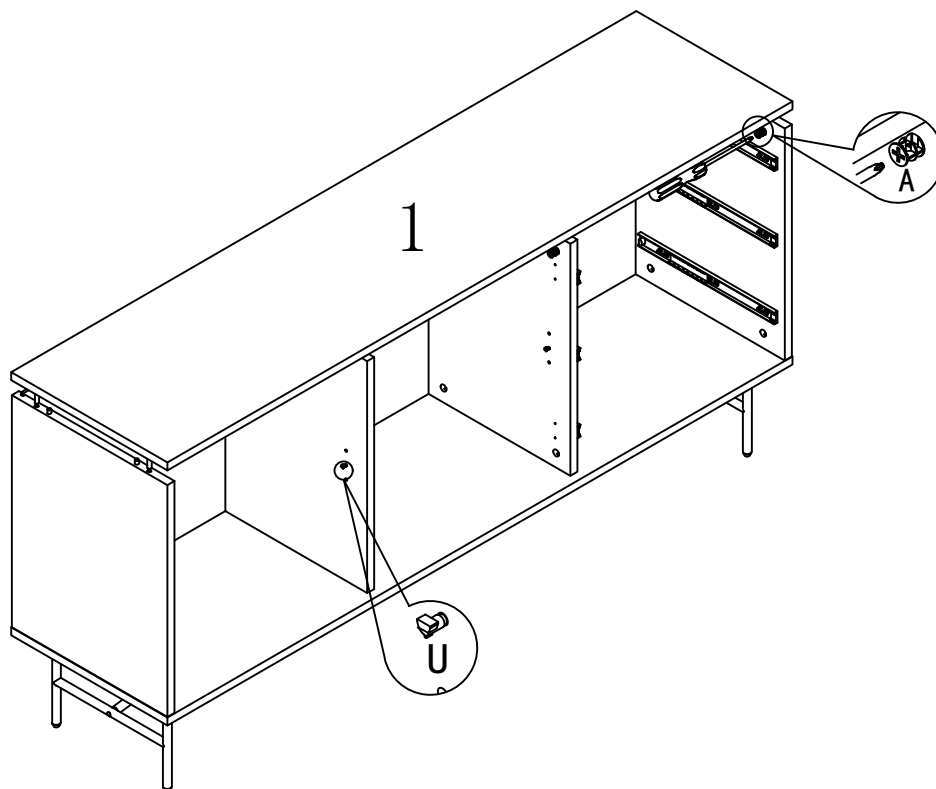
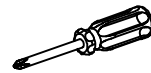

# 8

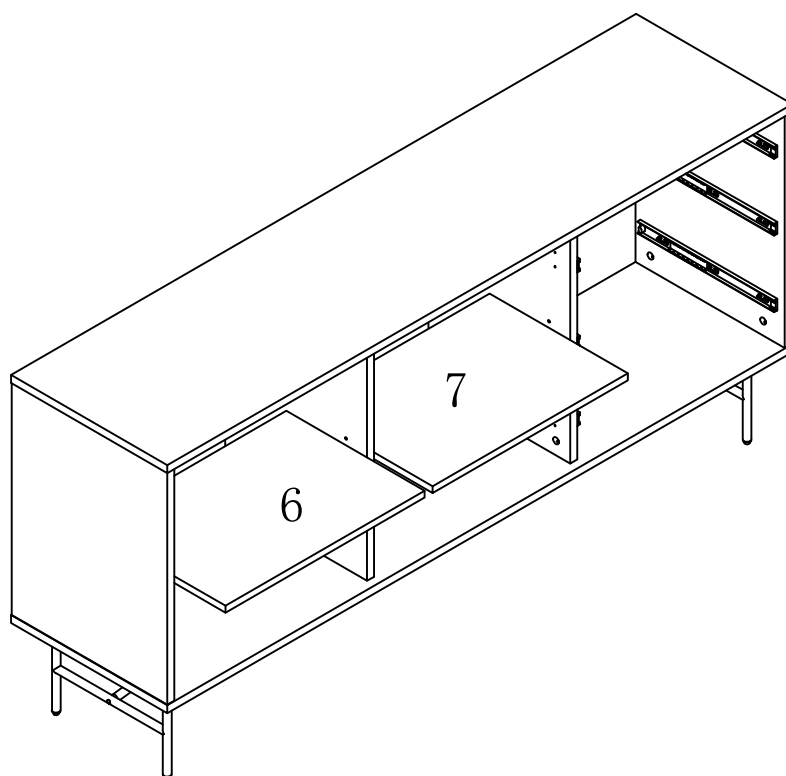

9-14

# 9

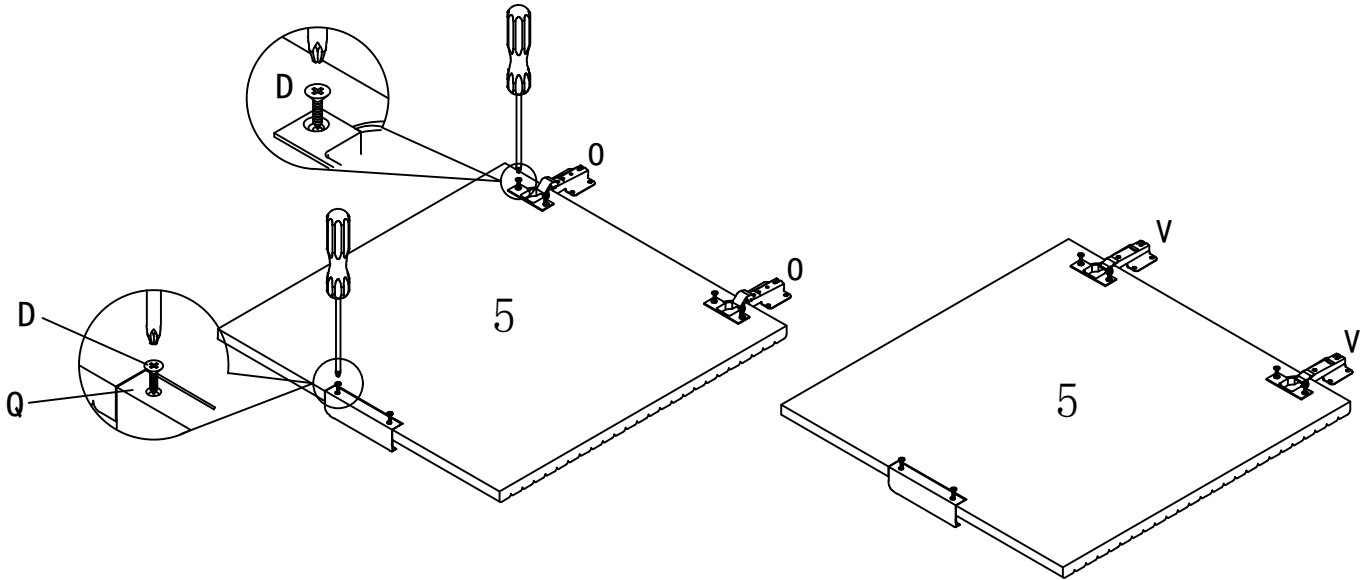
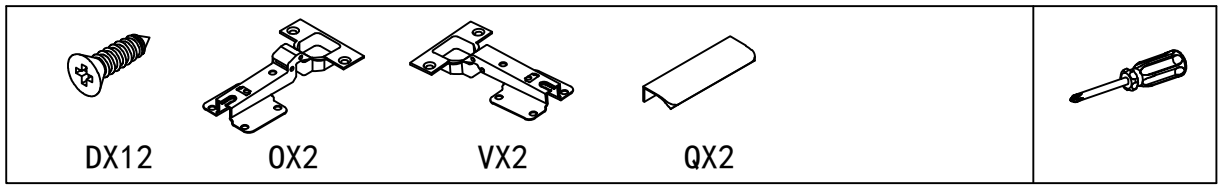

# 10

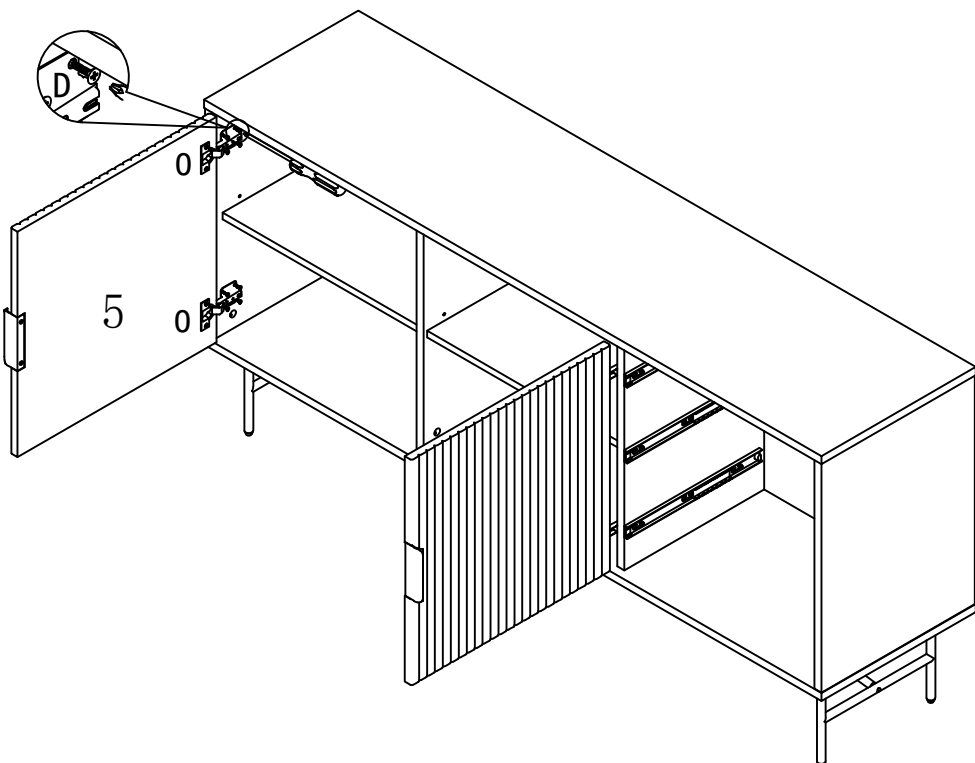

10-14

# 11

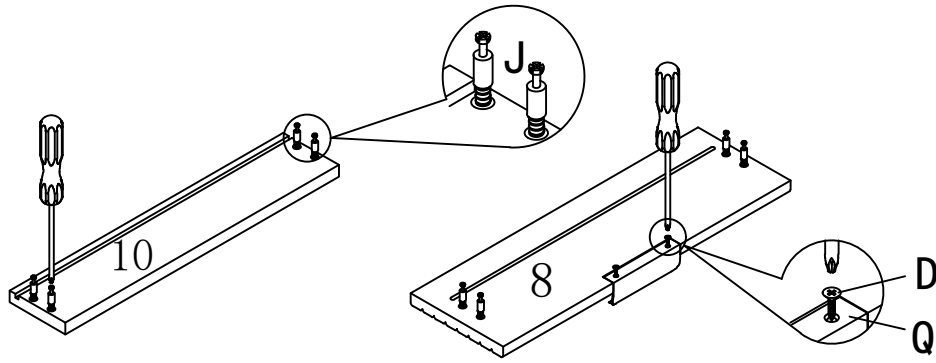
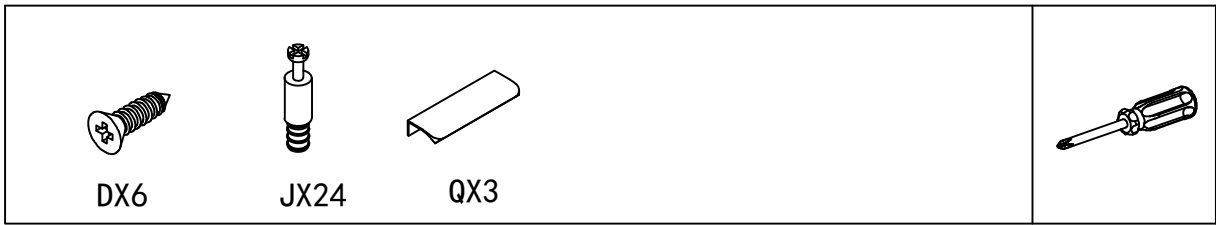

x3

# 12

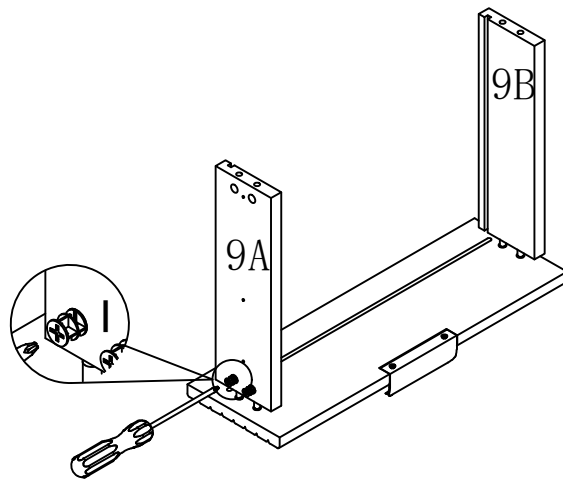
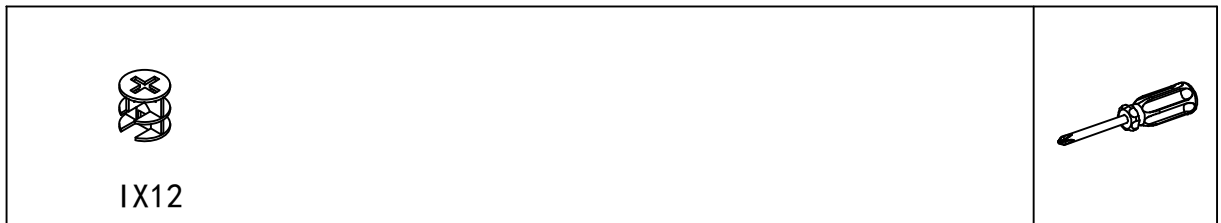

x3

# 13

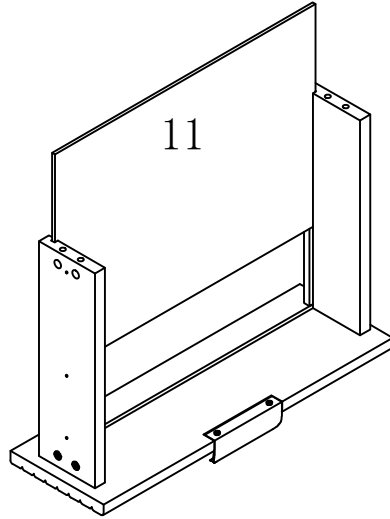

x3

# 14



IX12

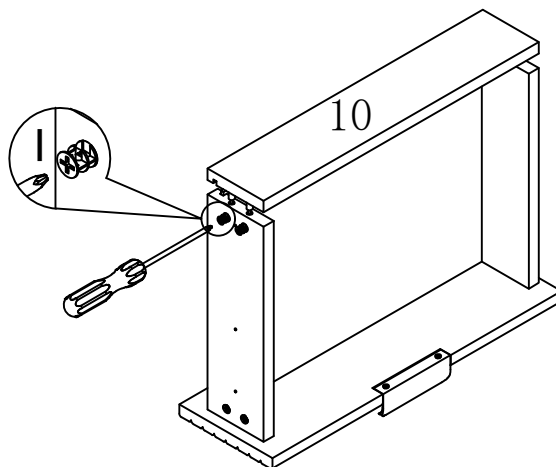
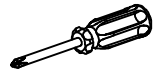

x3

12-14

# 15



DX18



H1X6

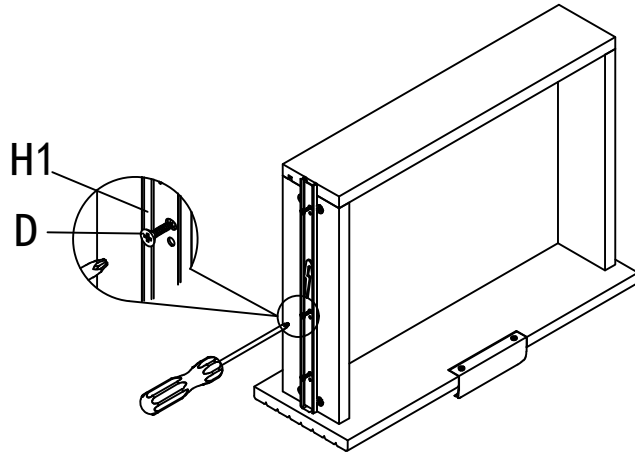
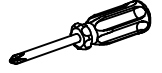

x3

# 16



NX12



DX12

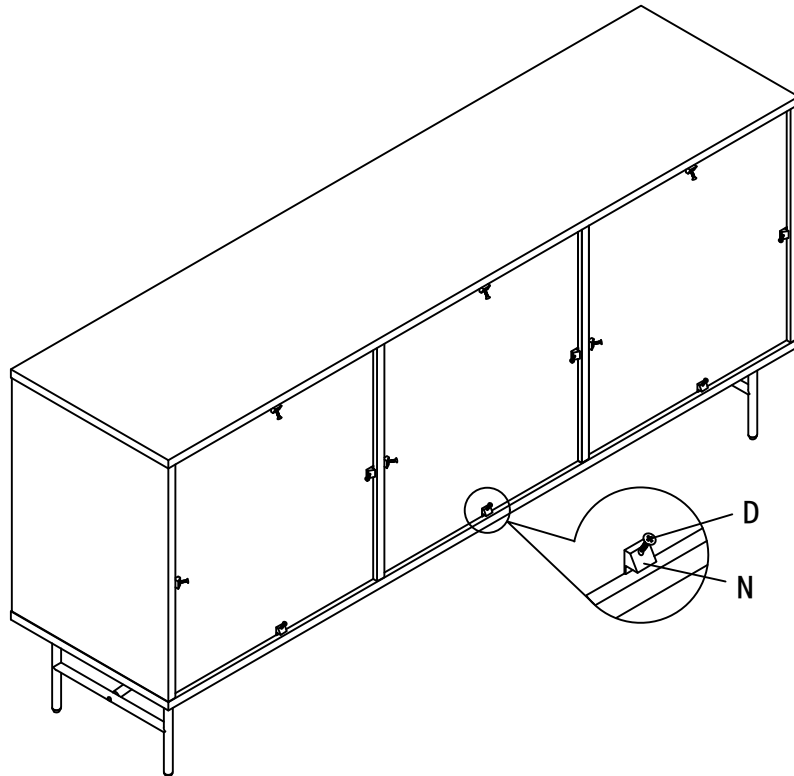
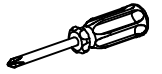

13-14

17

