

18687 (ET224 IB)

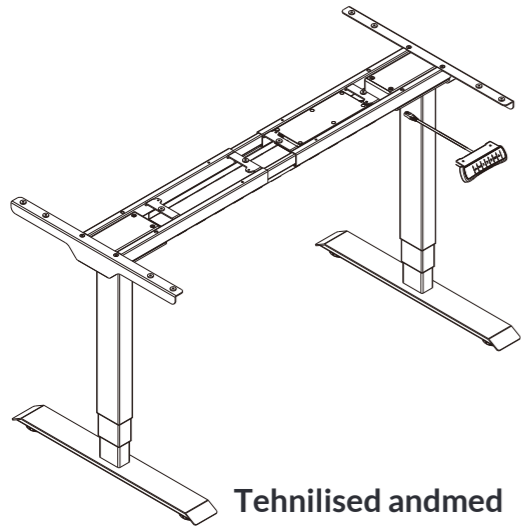

Tehnilised andmed

Tõstefaas	3
Kandevõime	125KG
Kõrgus	600-1250mm
Laius	1100-1900mm

Kinnitustarvikute loetelu

Juhendis toodud joonised on illustratiivsed.
Juhul kui mõni osa on pakendist puudu või tekib probleeme toote kokkupanemisega, võtke ühendust müüjaga.

Nr	Pilt	Osa	Tk
A		M6	4
B		M6	4
C		M6	8
D		M6	12
E		St4.2	16
F		Võti 4x4mm	1

Osade loetelu

Nr	Osa	Tk	Nr	Osa	Tk
①		2	②		2
	Jalg			Tõstejalg	
③		1	④		1
	Kaablirenn			Tugitala ja juhtplokk	
⑤		2	⑥		1
	Küljetugi			Juhtpult	
⑦		1			
	Voolujuhe				

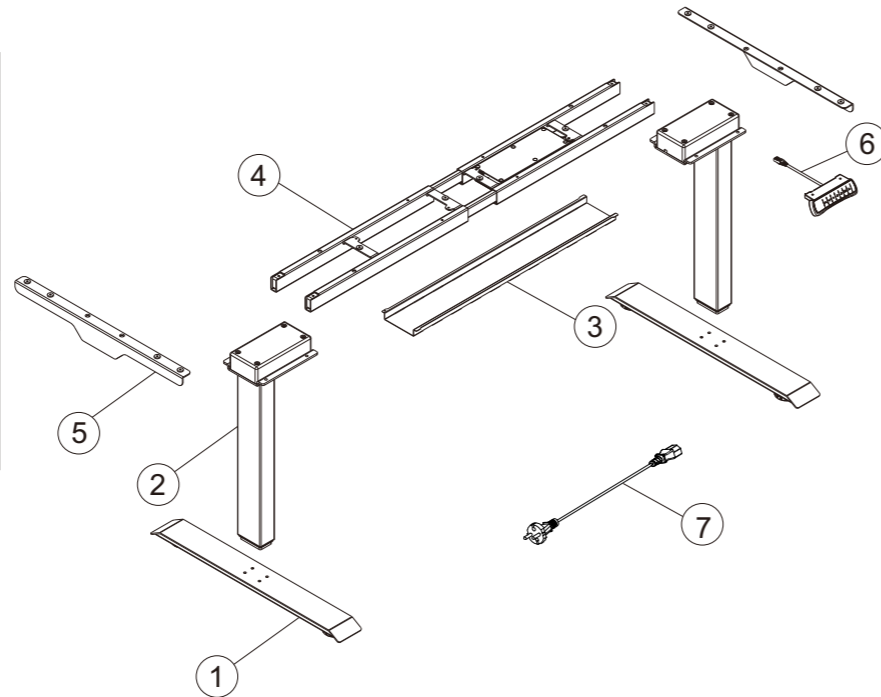

SAMM 1

Paigaldage küljetoed

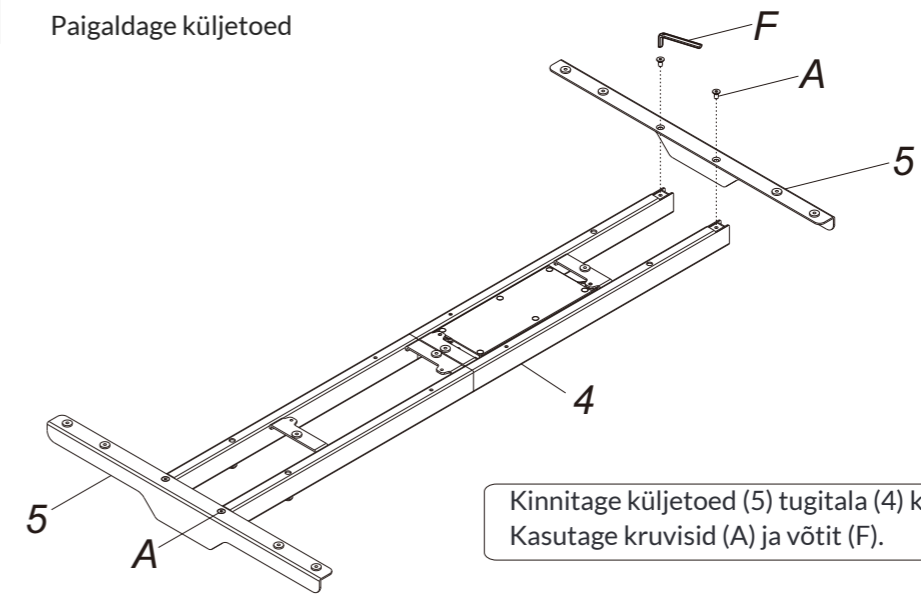

Kinnitage küljetoed (5) tugitala (4) külge.
Kasutage kruvisid (A) ja võtit (F).

SAMM 2

Paigaldage tõstejalad

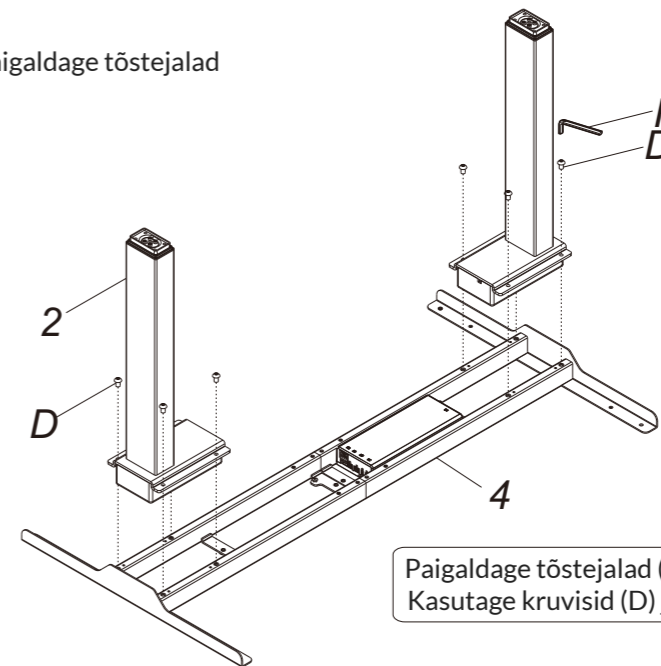

Paigaldage tõstejalad (2) tugitala (4) otstesse.
Kasutage kruvisid (D) ja võtit (F).

SAMM 3

Paigaldage jalad.

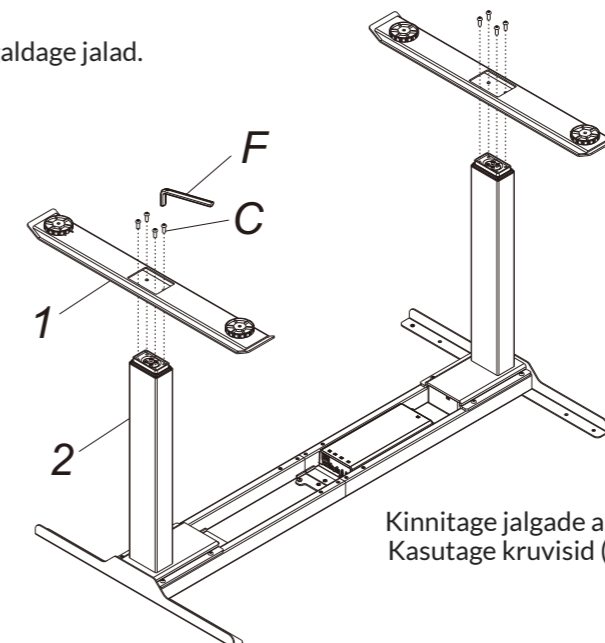

Kinnitage jalgade alused (1) tõstejalgade (2) külge.
Kasutage kruvisid (C) ja võtit (F).

SAMM 4

Paigaldage lauaplaat.

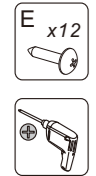

1

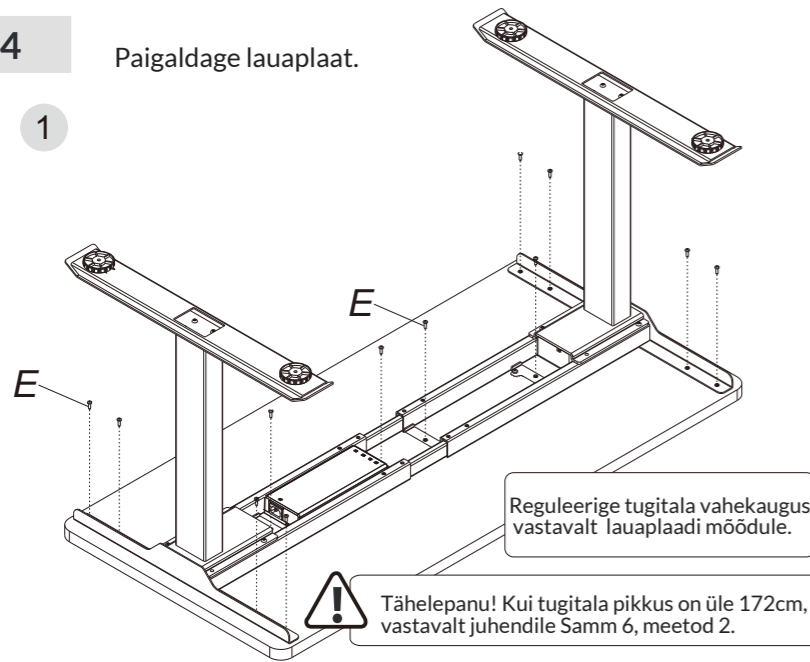

Reguleerige tugitala vahekaugus vastavalt lauaplaadi mõõdule.



Tähelepanu! Kui tugitala pikkus on üle 172cm, siis paigaldage vastavalt juhendile Samm 6, meetod 2.

2

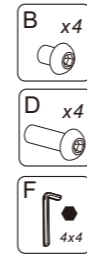
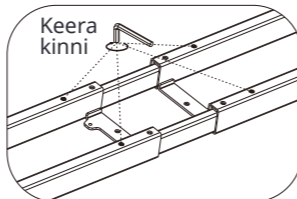
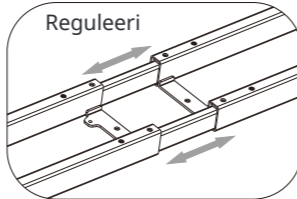
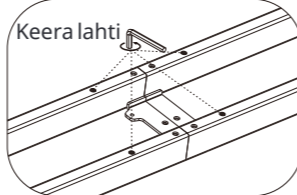

Meetod 2

Paigaldage kaablirenn vastavalt juhisele Samm 6, Meetod 1.

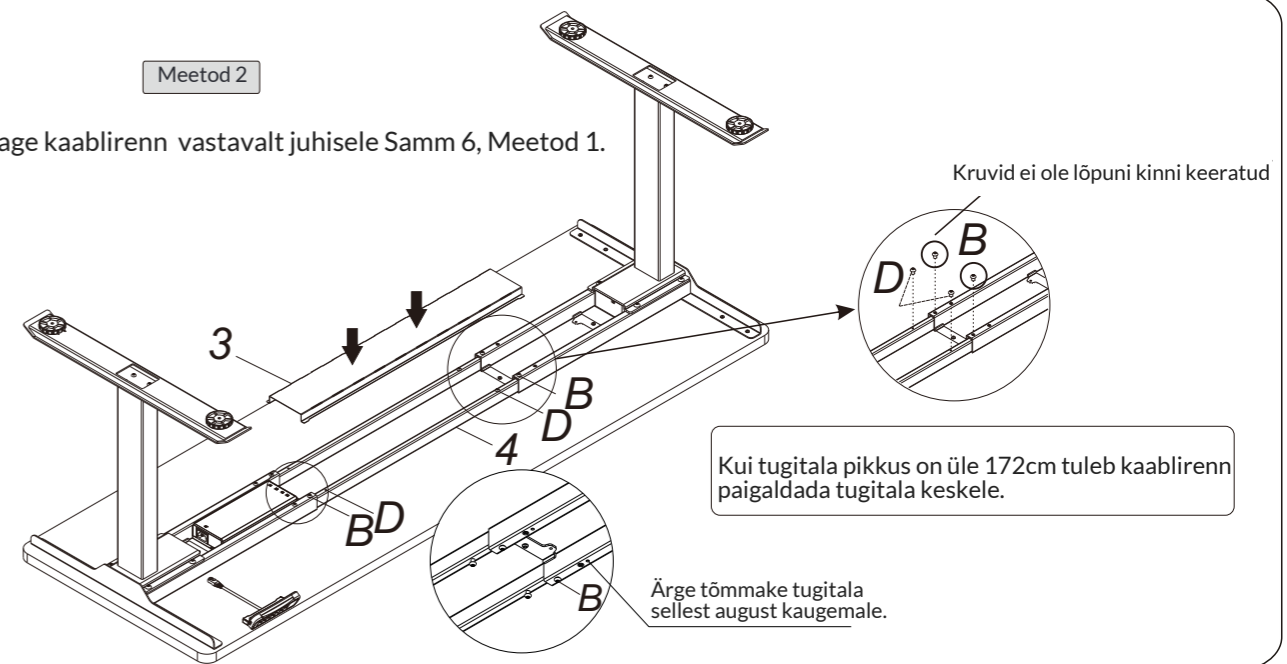

Kruvid ei ole lõpuni kinni keeratud

Kui tugitala pikkus on üle 172cm tuleb kaablirenn paigaldada tugitala keskele.

Ärge tõmmake tugitala sellest august kaugemale.

SAMM 5

Paigaldage juhtpult

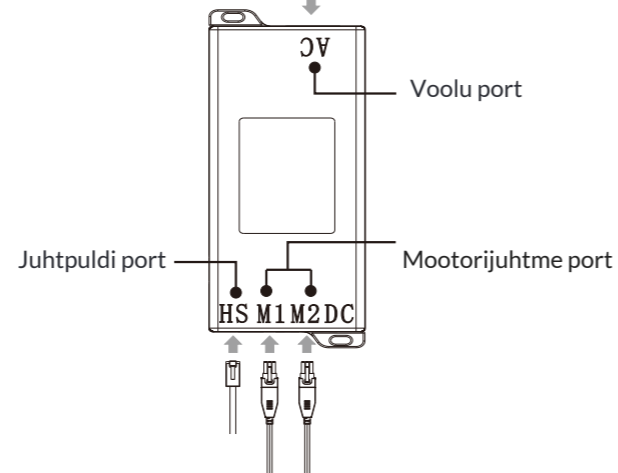
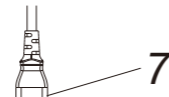
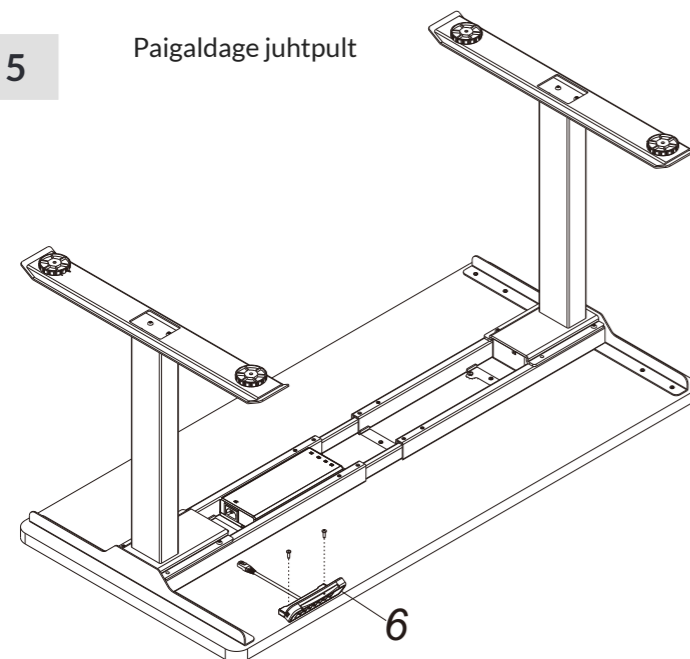

VEAOTSING

Alljärgnevad nõuanded aitavad teil kõrvaldada ja vältida enimlevinud probleeme elektriliselt reguleeritava laua kasutamisel. Kontrollige regulaarselt kaableid ja ühenduskohti. Ärge ülekoormake lauda. Ärge püüdke lauda ise remontida või täiustada. Probleemide korral võtke ühendust müüjaga või pöörduge vastava pädevusega sertifitseeritud teenusepakkuja poole.

Vooluvõrku ühendamisel seade ei reageeri pikale "alla" või "üles" nupu vajutamisele:

1. Kontrollige üle kõik kaablid ja ühenduskohad.
2. Võtke ühendust müüjaga.

Laud tõuseb liiga aeglaselt:

1. Veenduge, et laud ei ole ülekoormatud. Mx 125kg.
2. Võtke ühendust müüjaga.

Mootor ei tööta õigesti:

1. Pöörduge müüja poole.

Laud liigub alla, kuid mitte üles:

1. Proovige kõrgust muuta.
2. Pöörduge müüja poole.

Laud libiseb alla:

1. Veenduge, et laud ei ole ülekoormatud. Max 125kg.
2. Pöörduge müüja poole.

Laud vajab sageli uuesti reguleerimist:

1. Veenduge, et laud ei ole ülekoormatud. Max 125kg.
2. Pöörduge müüja poole.

Ületöötamine (Töötsükkel 2min ON / 18min OFF):

1. Tehke restart peale 18min pausi.

Laud ei tõuse või ei lange soovitud kõrgusele:

1. Vajutage samaaegselt 3 sekundi vältel nuppe M ja 3. Pidev helisignaal annab märku, et tehaseseaded on taastatud.
2. Pöörduge müüja poole.



TÄHELEPANU!

1. Toiteallikas AC100V - 240V, 50/60Hz.
2. Töökeskkond 0-40°C
3. Enne puhastamist ühendage seade vooluvõrgust lahti. Pühkige tolmu õrnalt niiske lapiga. Jälgige, et veetilgad ei langeks elektrilistele osadele ja et kaablite ühendused ei tuleks lahti.
4. Elektrilised osad sisaldavad elektroonilisi komponente, metalli, plastikut ja juhtmeid. Utiliseerige vastavalt kehtivale jäätmeseadusele.
5. Enne kokkupanemist tutvuge põhjalikult kokkupanekujuhendiga.
6. Enne kasutamist tutvuge põhjalikult funktsioonide ja kasutusjuhendiga.
7. Turvalisuse huvides ärge lubage lastel lauaga mängida.
8. Positsiooni muutmisel tekkiv väike müra on normaalne nähtus ning ei mõjuta seadme kasutamist.
9. Söövitava või abrasiivse toimega puhastusvahendite kasutamine on keelatud.
10. Elektriliselt reguleeritav töölaud on mõeldud kasutamiseks täiskasvanutele või lastele vanuses 8+.
11. Juhul kui toitejuhe on kahjustatud tuleb see välja vahetada. Tellige elektritööd ainult vastava pädevusega sertifitseeritud teenusepakkujalt.
12. Jälgige, et laua kokkupanemise ajal ei oleks tööriistad ja pakkematerjal lastele kättesaadavad.
13. Hoidke pakend ja kasutusjuhend alles.

SAMM 6

Paigaldage kaablirenn



Meetod 1

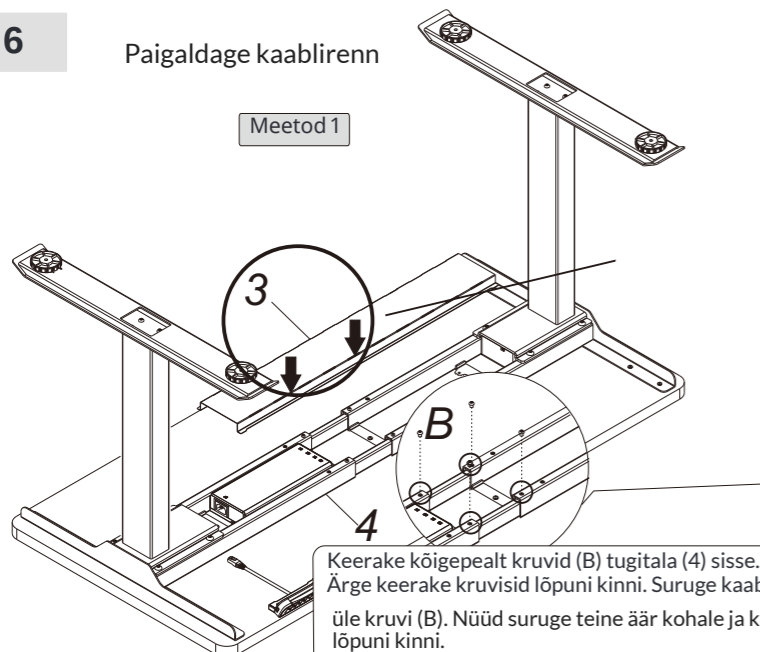

Keerake kõigepealt kruvid (B) tugitala (4) sisse. Kasutage võtit (F). Ärge keerake kruvisid lõpuni kinni. Suruge kaablirenni (3) üks äär üle kruvi (B). Nüüd suruge teine äär kohale ja keerake kruvid lõpuni kinni.

1

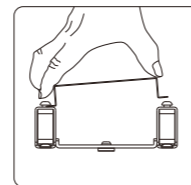
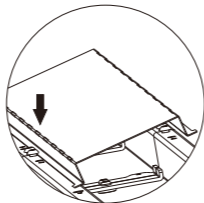

2

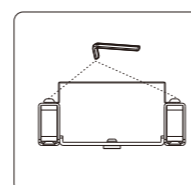
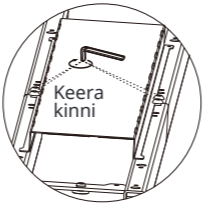
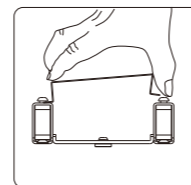
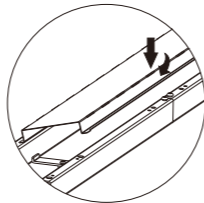

JÄÄTMEKÄITLUS



Hävitamisele kuuluv toode ei sobi olmeprügi hulka. Ennetage keskkonna- ja terviseriske ning utiliseerige toode vastavalt kehtivale jäätmeseadusele. Materjalide jätkusuutliku kasutamise edendamiseks ja võimalike keskkonnakahjude vältimiseks, käideldge taaskasutatavaid materjale ja elektroonikat sisaldavaid tooteid vastutustundlikult. Järgige kehtivat jäätmeseadust.

JUHTPULDI KASUTAMINE

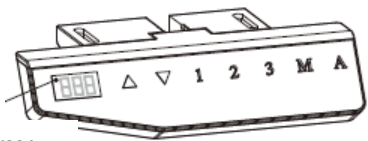

LED ekraan

- “▲” Laua kõrguse tõstmine.
- “▼” Laua kõrguse langetamine.
- “1” Positsioon 1: kasutaja poolt salvestatud esimene kõrgus.
- “2” Positsioon 2: kasutaja poolt salvestatud teine kõrgus.
- “3” Positsioon 3: kasutaja poolt salvestatud kolmas kõrgus.
- “M” MÄLU nupp
- “A” ALARM nupp positsioonivahetuse meeldetuletuseks.

- Vajutage UP või DOWN nuppu laua kõrguse seadistamiseks. LED ekraanil kuvatakse laua kõrgus reaalajas. Kõrgust on võimalik reguleerida vahemikus 60 – 125cm.
- Positsioonide salvestamine
 - a. reguleerige UP ja DOWN nuppude abil laua kõrgus sobivaks (näiteks 80cm).
 - b. vajutage mälu nuppu M. LED ekraanil kuvatakse S -, seejärel vajutage 1 esimese positsiooni salvestamiseks. LED ekraanil kuvatakse S – 1. Nüüd on positsioon 1 salvestatud kõrgusele 80cm.
 - c. salvestage samal viisil positsioon 2 valides näiteks laua kõrguseks 100cm. Kui positsioon on salvestatud kuvatakse LED ekraanil S – 2. Salvestage kolmas positsioon samal viisil näiteks kõrgusele 120cm. LED ekraanil kuvatakse S – 3.
 - d. laua positsiooni muutmiseks varem salvestatud asendisse vajutage lihtsalt 1, 2 või 3.
- Meeldetuletus töölaua kõrguse muutmiseks
 - a. vajutage nuppu A funktsiooni aktiveerimiseks. LED ekraanil kuvatakse ON.
 - b. 2 sekundi möödudes, kui ekraan vilgub seadistage noole nuppude abil meeldetuletuse aeg. Aja salvestamiseks vajutage ükskõik millist nuppu või oodake 5 sekundit ja aeg salvestub automaatselt. Mis tahes muutus taimeri töötamise ajal taaskäivitab taimeri. Kui valitud ajaperiood saab täis käivitub 10 sekundiline helisignaal – DID...DIDI...DIDI.
 - c. helisignaali ajal võite vajutada ükskõik missugust nuppu taimeri deaktiveerimiseks. Kui signaalile reageeringut ei järgne käivitub kordusmeeldetuletus 5 minuti pärast. Peale teist helisignaali lülitub taimer välja.
 - d. meeldetuletuse lõpetamiseks vajutage ja hoidke A nuppu all 3 sekundit. LED ekraanile kuvatakse OFF.

Item No.: ET224(IB)

Installation guide

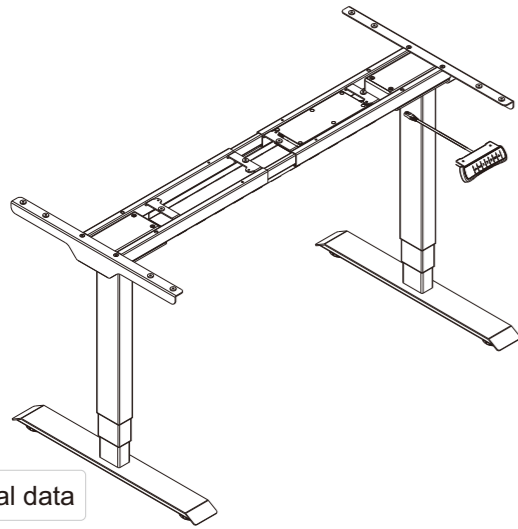

Technical data

Column Stage	3
Max. Weight Capacity	125KG
Height Range	600-1250mm
Width Range	1100-1900mm

Accessory list

Attention: The drawings below are for guidance only and they may differ slightly from the product and fittings received. Please contact our customer service department should you have any queries.

No.	Image	Spec	Qty
A		M6	4
B		M6	4
C		M6	8
D		M6	12
E		St4.2	16
F		Allen Key 4x4mm	1

Component list

No.	Part	Qty	No.	Part	Qty
①	Feet	2	②	Lifting Column	2
No.	Part	Qty	No.	Part	Qty
③	Cable Management Tray	1	④	Supporting Beam (Control Box included)	1
No.	Part	Qty			
⑤	Side Bracket	2	⑥	Hand Switch (Option)	1
No.	Part	Qty			
⑦	Power Plug	1			

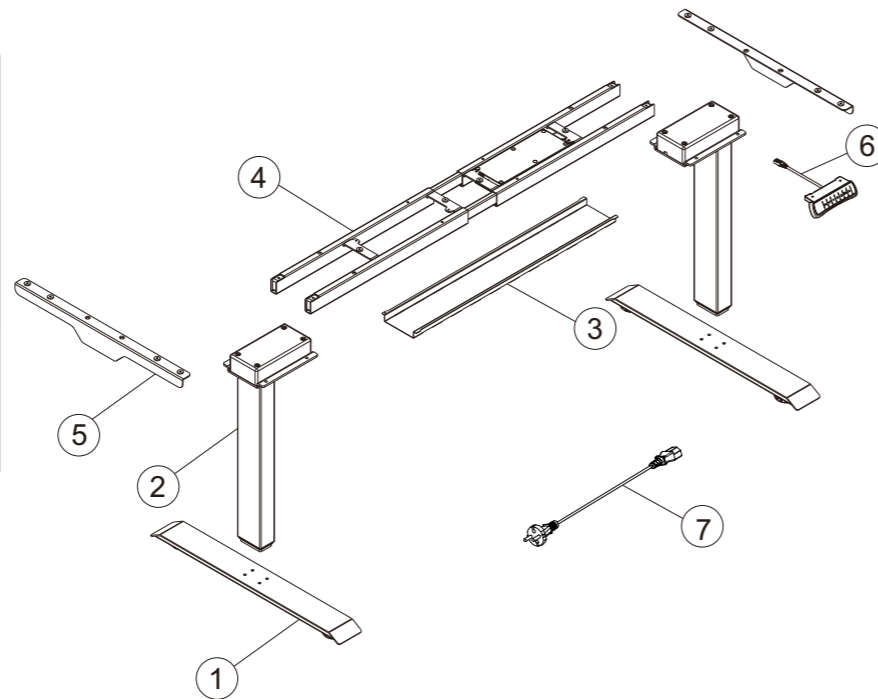

STEP 1

Install the Side Brackets

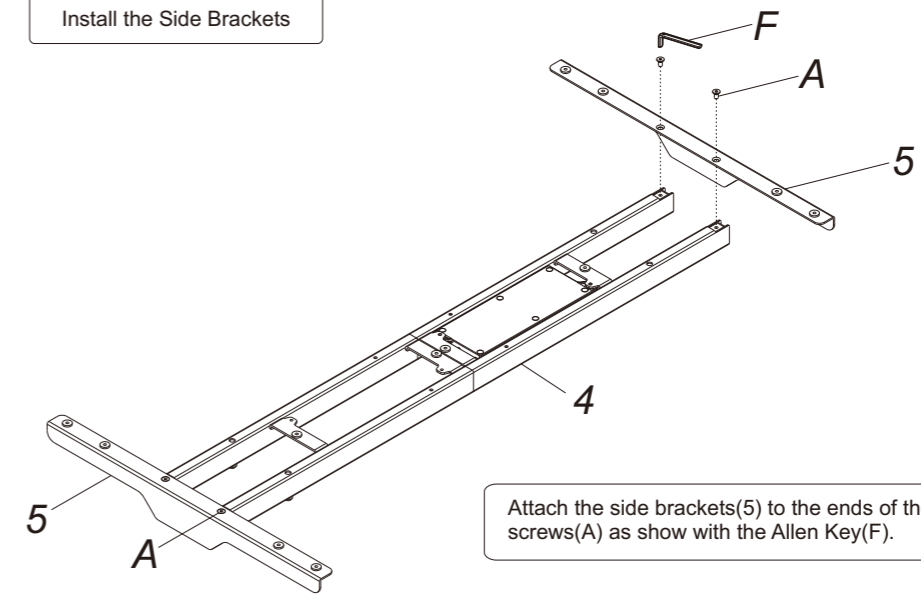

Attach the side brackets(5) to the ends of the supporting beam (4) using screws(A) as show with the Allen Key(F).

STEP 2

Install the Lifting Columns

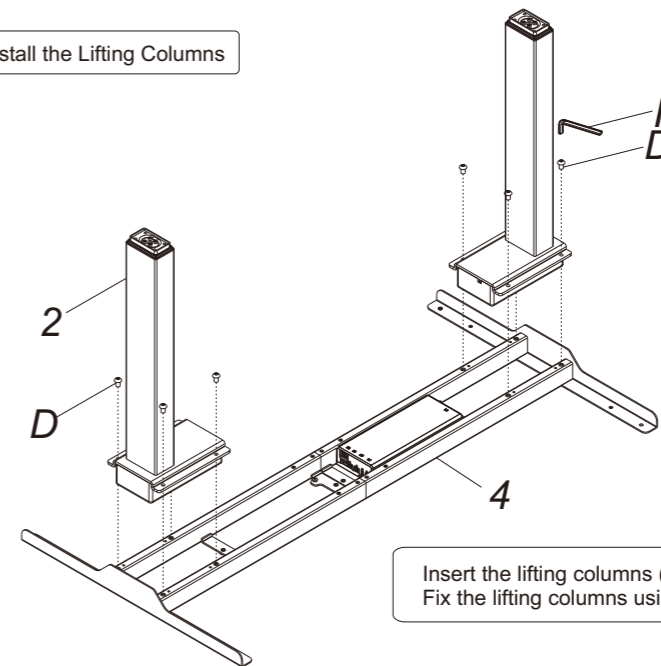

Insert the lifting columns (2) into the ends of the supporting beam(4). Fix the lifting columns using screws(D) with the Allen Key(F).

STEP 3

Install the Feet

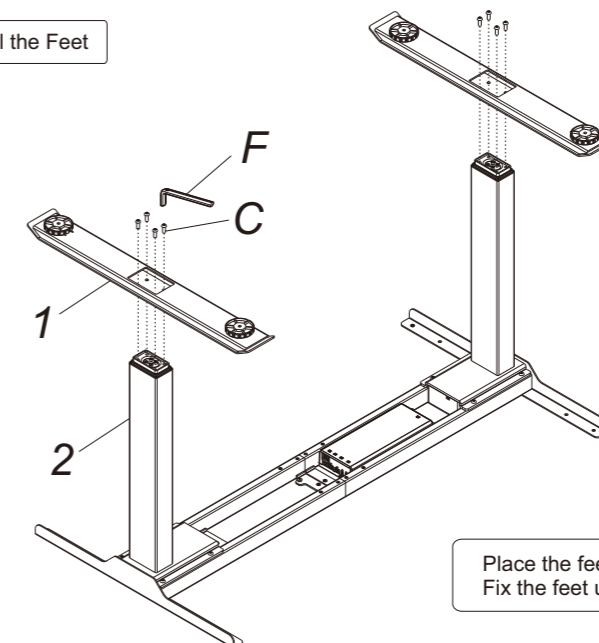

Place the feet(1) on the bottom of the lifting column(2). Fix the feet using screws(C) with Allen Key(F).

STEP 4

Install the Tabletop

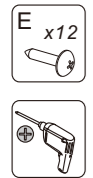

1

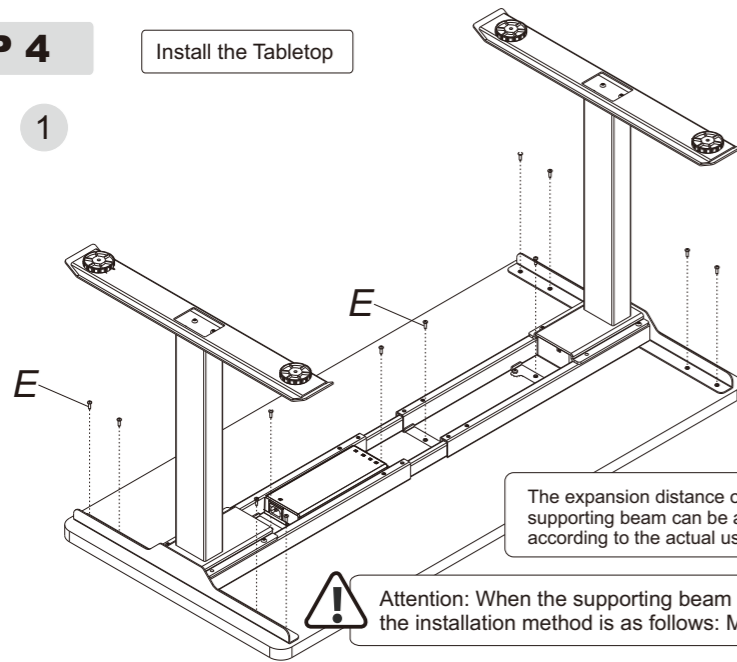

The expansion distance of the supporting beam can be adjusted according to the actual use.

Attention: When the supporting beam is greater than 1720mm, the installation method is as follows: Method 2 in Step 6.

2

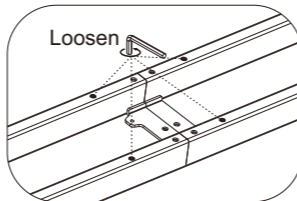

Adjust

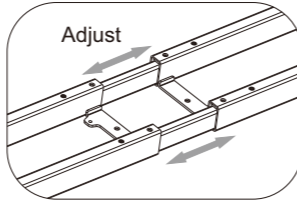

Tighten

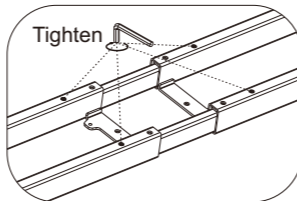

Method 2

Install the cable management tray as Method 1, Step 6.

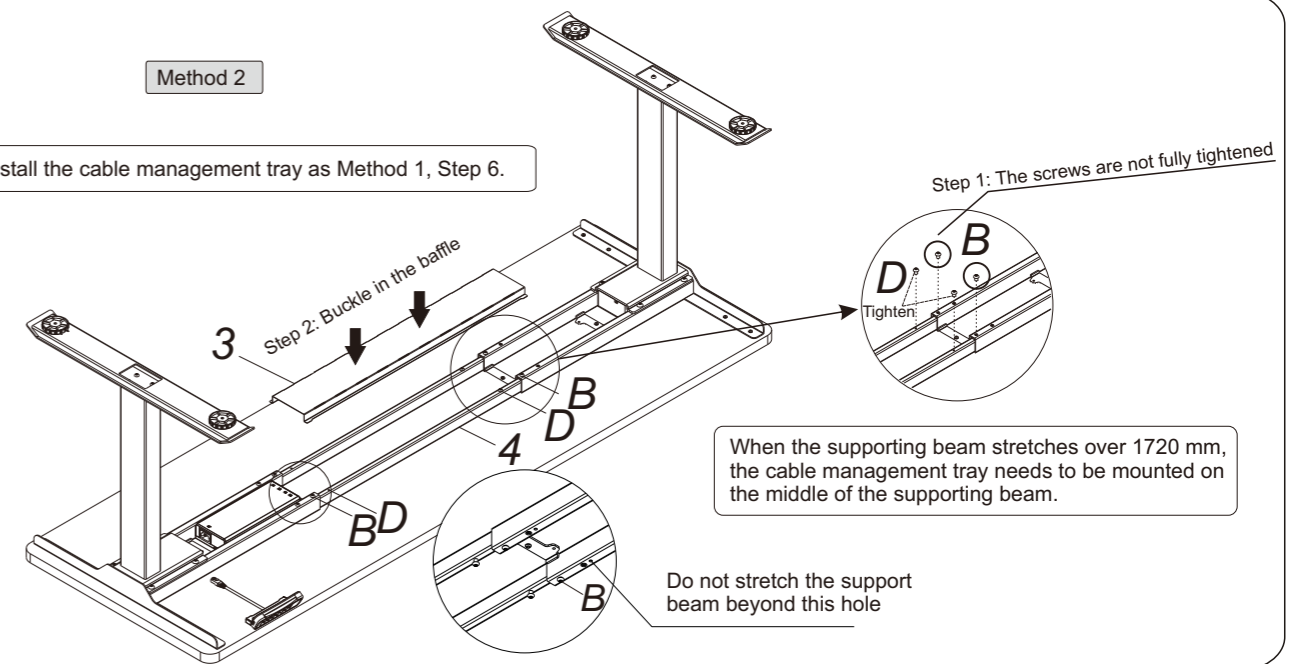

Step 1: The screws are not fully tightened

When the supporting beam stretches over 1720 mm, the cable management tray needs to be mounted on the middle of the supporting beam.

Do not stretch the support beam beyond this hole

STEP 5

Install the Control Panel

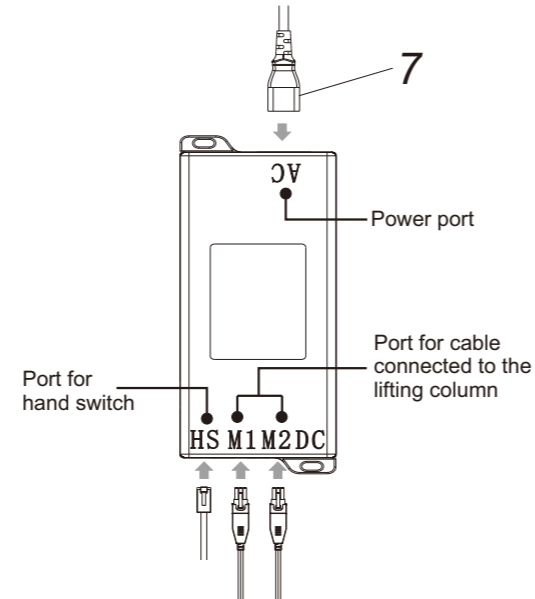
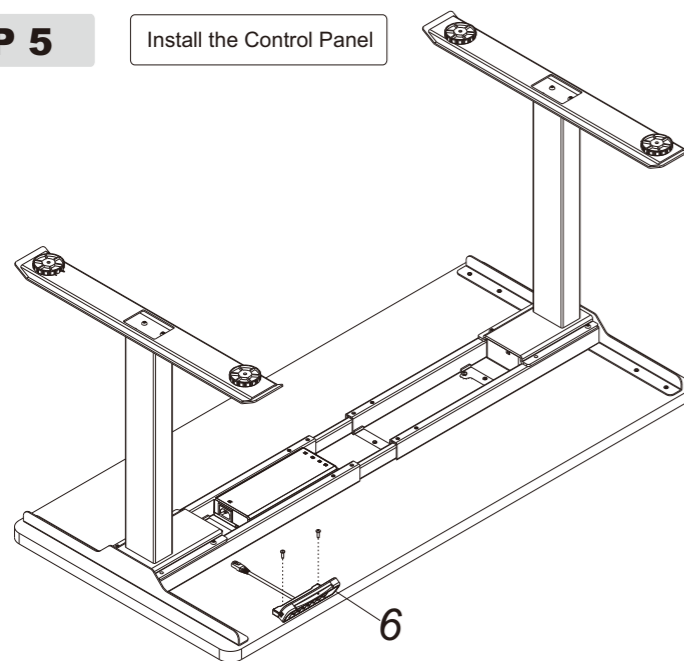

STEP 6

Install the Cable Management Tray

Method 1

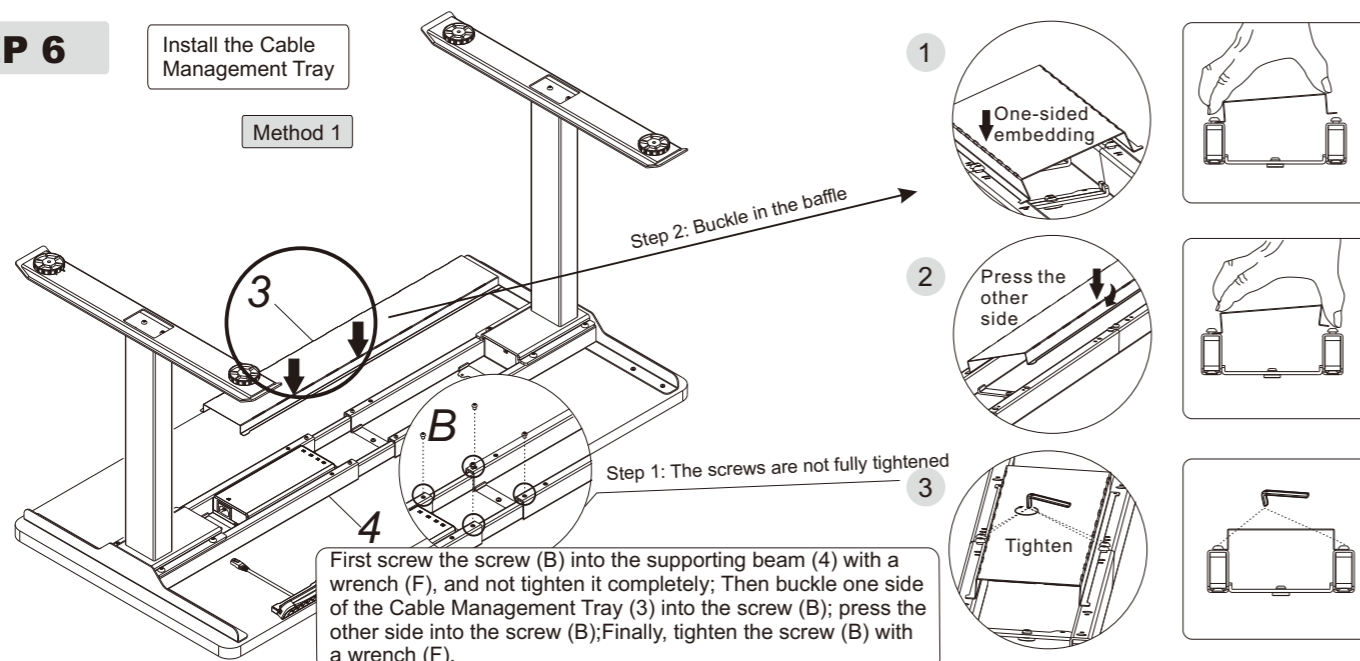

1

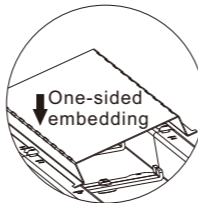

2

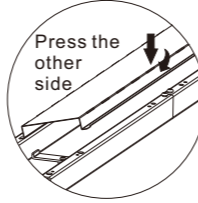

3

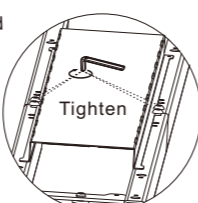

First screw the screw (B) into the supporting beam (4) with a wrench (F), and not tighten it completely; Then buckle one side of the Cable Management Tray (3) into the screw (B); press the other side into the screw (B); Finally, tighten the screw (B) with a wrench (F).

Common fault treatment

The following tips will help you detected and eliminate the common fault and error. If the fault you met is not listed below, please contact with your supplier. Only the manufacturer and professionals are capable for investigating and correcting those fault and error.

Fault phenomenon	Method
No response while long pressing down arrow after connected with a power supply	1. Check if all the cables be connected well 2. Contact your supplier or dealer
No response while pressing up arrow/ down arrow after connected with a power supply	1. Check if all the cables be connected well 2. Contact your supplier or dealer
Rising in a low speed	1. Check if overloaded, max loading: 125kg; 2. Contact your supplier or dealer
The motor not move as instructed	1. Contact your supplier or dealer
Go down but not go up	1. Reposition 2. Contact your supplier or dealer
Downward sliding	1. Check if overloaded, max loading: 125kg; 2. Contact your supplier or dealer
Frequently Reposition	1. Check if overloaded, max loading: 125kg; 2. Contact your supplier or dealer
Overwork (Duty cycle: Max 2min on/18min OFF)	1. Restart after suspend for 18mins while connecting with power; 2. Contact your supplier or dealer;
Not enough up&down height	1. Press "M" and "3" together for 3 seconds or more, after hearing continuous beeping for twice, it will restore factory settings 2. Contact your supplier or dealer

Attention

- Power supply: AC100V-240V,50/60Hz
- Service Environment: 0-40°C
- Unplug the power plug before cleaning, wipe the dust on surface with slight wet dishcloth when cleaning, be careful not to let the drops into the internal parts, not loose the connector.
- The electric box contains electronic components, metals, plastics, wires etc., so dispose of it in accordance with each country's environmental legislation, not the general household waste.
- Check carefully to ensure correct and complete assembly before using.
- Be familiar with all functions and program settings of the product before first use.
- Children are forbidden to play on the product because of unforeseen action when playing, so any dangerous consequences caused by this improper action will not be on
- Slight noise caused by the V-ribbed belt or brake system due to structure will not have any effect on the use of the equipment.
- Corrosive or abrasive materials are forbidden to clean the equipment. Must ensure that the cleaner used will not pollute the environment.
- This appliance can be used by children aged from 8 years and above and persons with reduced physical, sensory or mental capabilities or lack of experience and knowledge if they have been given supervision or instruction concerning use of the appliance in a safe way and understand the hazards involved. Children shall not play with the appliance.
- Cleaning and user maintenance shall not be made by children without supervision.
- If the supply cord is damaged, it must be replaced by the manufacturer, its service agent or a similarly qualified person in order to avoid a hazard.
- Please make sure there is no hazard sources in your operating environment. e.g., do not litter the tools around. Always be careful to treat the packaging materials in order to avoid any possible danger, e.g. plastic bag may lead to choking hazard to children.
- Keep the original package of the equipment if necessary in case of the future use in transportation.

Waste disposal



This marking indicates that this product should not be disposed with other household wastes. To prevent possible harm to the environment or human health from uncontrolled waste disposal, recycle it responsibly to promote the sustainable reuse of material resources. To return your used device, please use the return and collection systems or contact the retailer where the product was purchased. They can take this product for environmental safe recycling.

Item No.: HS11A-1

Operation Instruction

1. Product Outline

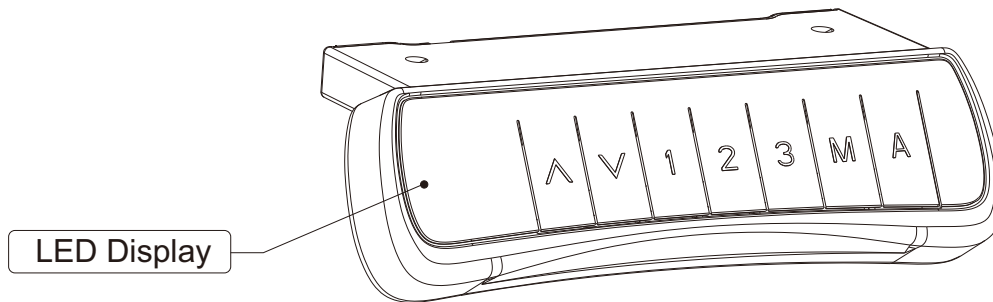

2. Product Specification

Button introduction: There are seven buttons that "▲", "▼", "1", "2", "3", "M", "A"

- (1) "▲" : Adjust the desk upwards
- (2) "▼" : Adjust the desk downwards
- (3) "1" : Position 1, first height position saved by the user
- (4) "2" : Position 2, second height position saved by the user
- (5) "3" : Position 3, third height position saved by the user
- (6) "M" : Height memory function
- (7) "A" : Alert button to remind users changing posture

3. Operating Instructions

- Height Adjustable Function:
Press the "▲" or "▼" button to adjust the height. The LED display shows the current height.
- Height Memory Function:
 - a. Press UP or DOWN button and adjust the height to the desired height. Press "M" to save the height, and the screen will display "5-";
Press "1", "2", or "3" then, that is, save the height to the corresponding position 1 or 2 or 3, which will show in the display screen as "5-1", "5-2", or "5-3";
 - b. Press "1", "2" and "3" button directly to automatically adjust the memory height you saved.

● **Reminder Function:**

- a. Press REMINDER button "A" to activate the function. The LED display shows "00" or "on".
- b. Two seconds later, press the "▲" or "▼" button to adjust the reminder time only when the display screen flashes. The default time of the reminder is 45 minutes, which is shown as "45". Then press any button to save the time setup, or wait 5 seconds and system will save the time setup automatically. During the countdown, any operation will lead to a repeat starting of the timer. When the countdown finishes, display screen will show "00" the buzzer will be active with a 10-second "DiDi...DiDi...DiDi..."tone.
- c. Within the 10-second reminder buzz, press any button to reactivate the time countdown that is set up in (b) step. If no operation during the 10-second reminder buzz, there will be another reminder buzz after 5 minutes. No operation during the second buzz will turn off the Long-Time Sitting Reminder.
- d. Press and hold the "A" button for three seconds to turn off the Long-Time Sitting Reminder. The LED display shows "OFF" or "off".

● **Anti-collision sensitivity adjustment - optional features:**

- a. Press and hold the "▲" "▼" button for 5 seconds at the same time to switch the sensitivity. Switch one level for 1 time and divide it into 4 levels (A-3, A-2, A-1, A-0);
- b. The display shows "A-0", the anti-collision function is off; the display shows "A-1", low sensitivity; Display shows "A-2", medium sensitivity; display shows "A-3", high sensitivity;
- c. During height adjustment, when tabletop comes in contact with another object, it instantly stops and reverses to avoid damage.
- d. Press and hold the "▲" "▼" button for 5 seconds at the same time. If the display does not display the above code, there is no anti-collision function.

● **Troubleshooting:**

- a. When the LED display shows "RST" or "rst", long press the down key "▼", the standing desk runs to the lowest or highest position and then runs in reverse until it stops, at this time the display shows the height number, release the down key "▼", After the reset, the desk can be used normally;
- b. When reporting the error code, short press the down key "▼" to enter the "RST" or "rst" state and perform the reset operation;
- c. If you perform the above operations, the desk still does not work properly, please contact customer service.

Waste disposal

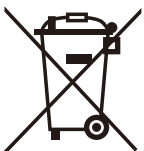

This marking indicates that this product should not be disposed with other household wastes. To prevent possible harm to the environment or human health from uncontrolled waste disposal, recycle it responsibly to promote the sustainable reuse of material resources. To return your used device, please use the return and collection systems or contact the retailer where the product was purchased. They can take this product for environmental safe recycling.